



Cast iron oil-fired
boilers

RONDÒ
ESTELLE
ESTELLE B Inox



 **sime**[®]



RONDÒ - ESTELLE - ESTELLE B INOX

The efficiency of oil

An ideal thermal input and a higher efficiency is what distinguishes the new generation of cast iron oil boilers **Rondò**[®] and **Estelle**[®]. They are available for sole heating or for heating and D.H.W. production (**Estelle B Inox** range) with an integrated inox tank of 110 litres of capacity. Both the **Rondò**[®] and the **Estelle**[®] are designed and manufactured in

accordance with the EU Efficiency Directive. Each boiler, including all components, are subjected to very severe laboratory tests to guarantee a quality product and superior performance. The newly designed combustion chamber, which conforms to DIN standards, allows the boiler to be matched to most burners currently available.

Quality heat

The particular innovative design style of the combustion chamber maximises the use of the radiated heat and the hot gases produced by the

burner. The higher performance and lower noise levels are a result of the optimal division of the fins of the smoke circuit.

Greater comfort

To use the appliance is very simple and functional and the controls on the control panel are protected against accidental tampering. To enhance the performance a programmable time clock may be

attached to the control panel. To give even greater comfort a thick layer of insulation covers the body of the boiler which reduces losses due to irradiation and at the same time reduces noise levels when operating.



List of functions / instruments

- | | |
|-----|--|
| ▶ 1 | Water switch interv. indicator (mod. Estelle B Inox) |
| ▶ 2 | Thermometer |
| ▶ 3 | Power on indicator |
| ▶ 4 | D.H.W. tank stat (mod. Estelle B Inox) |
| ▶ 5 | Boiler thermostat |
| ▶ 6 | Summer/winter switch (mod. Estelle B Inox) |
| ▶ 7 | Main switch |
| ▶ 8 | Limit stat (mod. Estelle B Inox) |
| ▶ 9 | Safety stat |

Plentiful hot water

Estelle B Inox, equipped with an 110 litres inox rapid hot water tank with a protective magnesium anode and an inspection flange permitting inspection and cleaning, supplies plenty of hot water, always at just the right temperature.

The hot water circuit is separate from the heating circuit to ensure rapid hot water production with low maintenance costs. Efficient insulation made with self-extinguishing polyurethane foam keeps water temperature constant for long periods of time.

Functioning

The boilers have been designed for the easy insertion of supporting brackets to facilitate the lifting and manoeuvring in the boiler house when installing. Particular attention has been given to the **Estelle®** in the design phase in order to quicken the

usual maintenance procedures.

Access to the internal body of the boiler is through the wide self-supporting door which will support the burner when opened. The reversible hinge allows the door to be opened from both sides.

Technical features

CE Rondò/Estelle		3	4	5	6	7	Estelle B4	Estelle B5
Output								
Minimum	kW (kcal/h)	18,9 (16.300)	24,5 (21.100)	32,5 (28.000)	41,7 (35.900)	49,9 (42.900)	–	–
Maximum	kW (kcal/h)	23,5 (20.200)	31,3 (26.900)	40,0 (34.400)	48,1 (41.400)	57,5 (49.500)	31,3 (26.900)	40,0 (34.400)
Input								
Minimum	kW (kcal/h)	21,1 (18.100)	27,2 (23.400)	36,0 (31.000)	46,1 (39.600)	55,0 (47.300)	–	–
Maximum	kW (kcal/h)	26,2 (22.500)	34,8 (29.900)	44,3 (38.100)	53,1 (45.700)	63,3 (54.400)	34,8 (29.900)	44,3 (38.100)
Sections	n°	3	4	5	6	7	4	5
Water content	l	12,8	16,8	20,8	24,8	28,8	19,8	23,8
Smokes loss of head								
Minimum/Maximum	mbar	0,05/0,11	0,12/0,16	0,15/0,21	0,30/0,35	0,32/0,43	–/0,16	–/0,21
Maximum water head	bar	4	4	4	4	4	4	4
D.H.W. tank capacity	l	–	–	–	–	–	110	110
D.H.W. flow rate Δt 30°C	l/h	–	–	–	–	–	830	830
D.H.W. maximum water head	bar	–	–	–	–	–	6	6
Weight	kg	109	135	161	186	212	203	229

Dimensions - Hydraulic connections

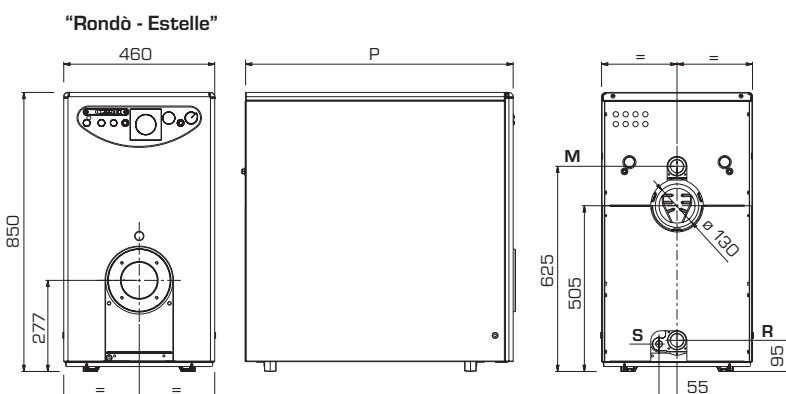

Dimensions - Hydraulic connections

	3	4	5	6	7
P Depth	415	515	615	715	815
M C.H. flow	1 1/4"	1 1/4"	1 1/2"	1 1/2"	1 1/4"
R C.H. return	1 1/4"	1 1/4"	1 1/2"	1 1/2"	1 1/4"
S Drain cock	1/2"	1/2"	1/2"	1/2"	1/2"

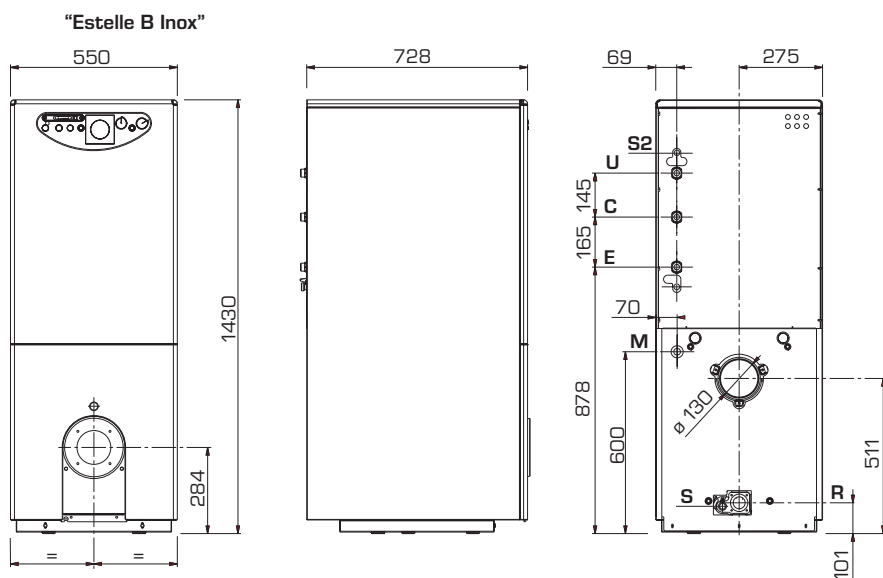

Hydraulic connections

	Estelle B
M C.H. flow	1"
R C.H. return	1 1/4"
E D.H.W. inlet	3/4"
U D.H.W. outlet	3/4"
C Re-circulation	3/4"
S Drain cock	
S2 Safety valve discharge	

Fonderie SIME S.p.A. pursues a policy of continuing improvement in design and performance of our products. The right is therefore reserved to vary specifications without notice.



Fonderie Sime S.p.A • Via Garbo, 27 • 37045 Legnago (Vr) Italy
Tel. +39 0442 631111 • Export Division Fax +39 0442 631293 • www.sime.it