



Fonderie Sime S.p.A. - Via Garbo, 27 - 37045 Legnago (VR) - [www.sime.it](http://www.sime.it)  
 Tribunale Verona 13531 - R.E.A. VR 171357 - C.C.P. 19423375 - N° Mecc. VR 014435  
 Capitale Sociale Euro 5.521.200 int. versato - Codice Fiscale/Partita IVA n. IT 01275930236

Comfort Ambiente - Via Garbo, 27 - 37045 Legnago (VR)

Tel +39 0442 631111 - Fax Servizio Commerciale: Italia +39 0442 631291 - Estero +39 0442 631293

Fax Servizio Tecnico +39 0442 631292 - Fax Ufficio Acquisti +39 0442 631292 - Fax Amministrazione +39 0442 631336

8107948 CALD.MET.METROP.DGT 30 BF

Metropolis DGT BF DIN 20-25-30 - interno- CINA-RUSSIA

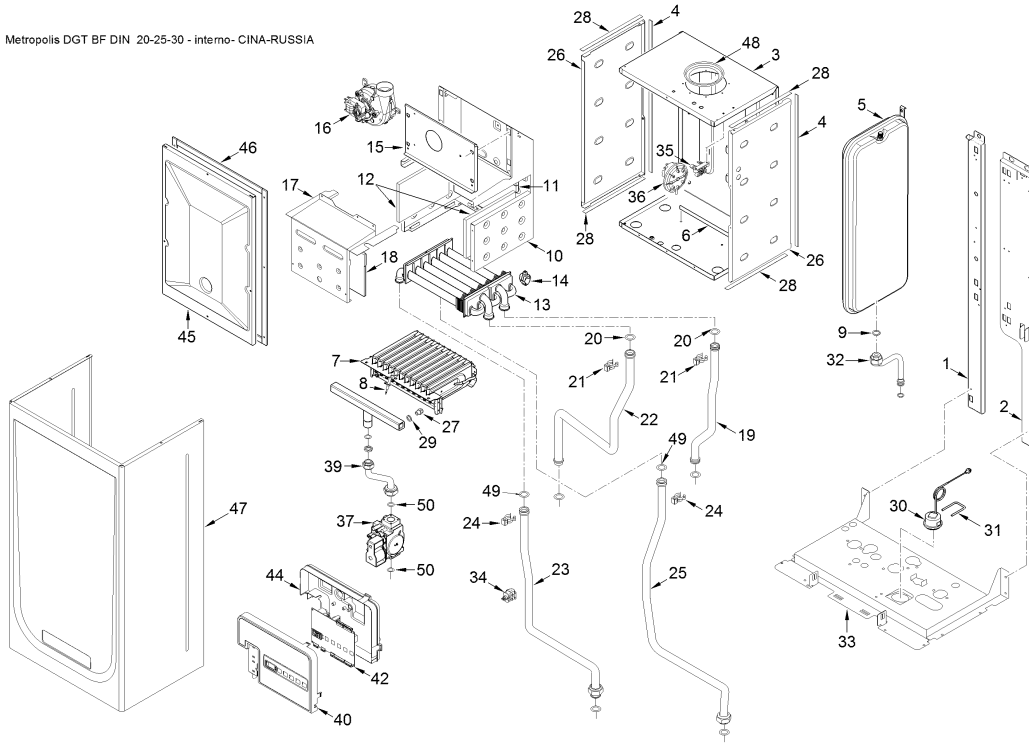

Metropolis DGT BF DIN 20-25-30 gr-idraulico - CINA-RUSSIA  
 Metropolis DGT OF DIN 25 gr-idraulico - UKRAINA

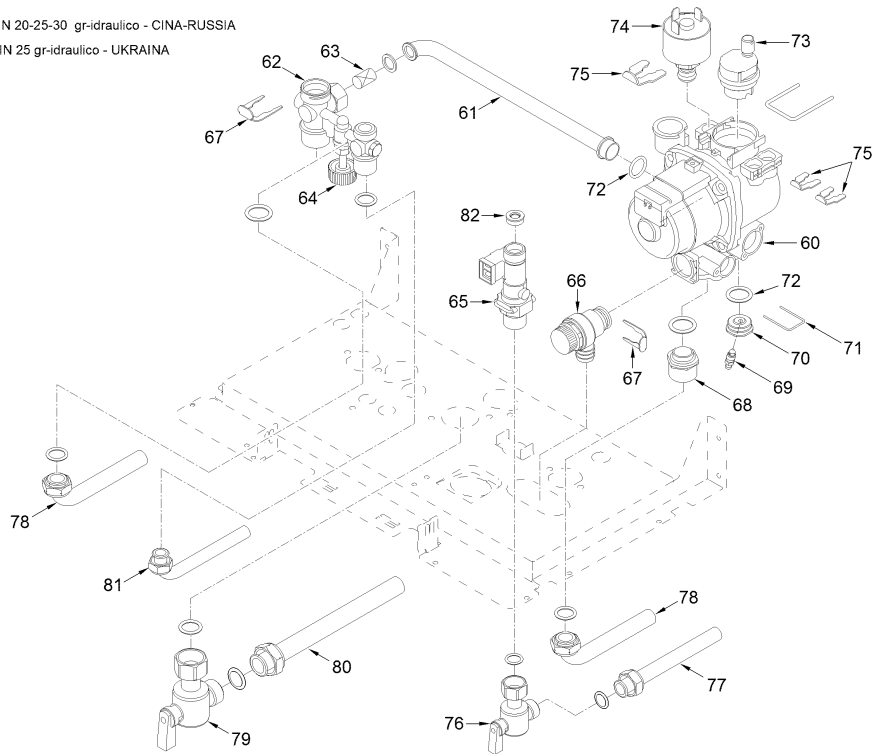

Posiz.	Codice	Descrizione
001	6318350	Left hand side frame part
002	6318300	Right hand side frame part
003	6317610	Sealed chamber rear panel
004	6229838	Gasket for sealed chamber
005	5183726	Rectang. expansion vessel 8 l.

006	6257532	Air deflector	
007	5198260	Main burner assembly	
008	6235932	Ignition-ionisation electrode	
009	6146330	Nut 1/2" for expansion vessel	
010	6318510	Smoke chamber assembly	
011	6318721	Combustion chamber rear insulat	
012	6318710	Combustion chamber side insulat	
013	6174259	Gas/Water heat exchanger	
014	6231362	NTC sensor	
015	6318610	Smoke chamber front panel	
016	6225634	Fan	
017	6317910	Combustion chamber front panel	
018	6318701	Combustion chamber side insulat	
019	6264862	C.H. return pipe	
020	6226412	O-ring 3068	
021	6226601	Spring for heat exchanger conne	
022	6264799	C.H. flow pipe	
023	6227035	D.H.W. outlet pipe	
024	6226617	Spring for heat exchanger conne	
025	6227133	Inlet pipe for D.H.W.	
026	6288210	Sealed chamber side panel	
027	6154402	Main burner nozzle NP 130 natur	MET
027A	6154414	Main burner nozzle NP 78 GLP	GPL
028	6229837	Gasket for sealed chamber	
029	6022004	Copper washer Ø 6	
030	6146112	Pressure gauge	
031	6226628	Hydrometer Fixing spring	
032	6130707	Expansion vessel connecting pip	
033	6318030	ELEM.INF.TELAIO METR.DGT 30 BF	
034	6231357	D.H.W. temperature sensor	
035	6229110	Smoke pressure switch bracket	
036	6225707	Air pressure switch	
037	6243833	Gas valve	
039	6195214	Gas inlet pipe	
040	6304751	Control panel	
041	6273220	Guidelight glass	
042	6301420	Main P.C.B.	
044	6305050	Control panel cover	
045	6317710	Sealed chamber front panel	
046	5192208	Gasket for sealed chamber	
047	6317831	Casing	
048	6028620	Air diaphragm Ø 81	
049	6226444	O-Ring Ø 13,64 x 2,62	
050	2030228	Gasket Ø 17x24x2	
060	6272330	Circulating pump	
061	6277793	Pipe connecting	
062	6265820	Manifold	
063	6270903	By-pass	
064	6013705	Knob	
065	6149318	Flow water switch 1/2"M.-1/2"M.	
066	6040215	Pressure relief valve 3 bar	
067	6226640	Spring clip	
068	6120559	Nipple 3/4"	
069	6119358	Raccord	
070	6119357	Brass cap	
071	6226641	Spring clip	
072	6226472	ORing 17.86x2.62	
073	6013182	Automatic air vent	
074	6037509	Water pressure switch	
075	6226639	Spring clip	
076	6177503	Ball cock 1/2"M x 1/2"F	
077	6142507	Pipe 1/2" x 14 L=135	
078	6142410	Bend 3/4"x18 L=135	
079	6177501	Gas cock 3/4" MF	
080	6142505	Pipe connecting jig 18X3/4X195	
081	6142409	Quarter bend 1/2" x 14 L=135	
700	5202200	Complete control panel	
701	6316252	6 pole Stocko connector CN6	
702	6316253	9 pole Stocko connector	
703	6323852	14 pole cable connector	
704	5144713	Conversion kit to LPG	
705	5202000	Hydraulic group	
706	6319695	Murelle-Format-.....o-ring kit	
707	6281534	Gaskets kit	
709	6245374	Circulating pump connector	