

# TIME

## Instruction Handbook for:

- ▶ use
- ▶ installation
- ▶ adjustment
- ▶ maintenance



25 F

30 F

35 F

CE  
0694

# Table of Content

---

## Safety warnings

Safety warnings symbols legend	4
References to Laws and Norms	4
Personnel in charge of installation	4
Installation, use and maintenance	4
User warnings	5
Important	5
First starting up and Use	5
Installation, first starting up, maintenance and servicing	6
Appliance booklet or central plant booklet	6
Combustion checking	6
Boiler operation and servicing	6

---

## User guide

Keyboard buttons	7
Multi-function display	8
Commands on the lower side	9
Commands outside the boiler	9
Typical use	10
Preliminary operations	10
Boiler activation	10
Temperature adjustment	10
Hour and day setting	11
Set the display with 4 digits	11
DHW pre-heating mode (Acqua Step)	11
To set the desired "step"	12
Manual set of Acqua Step	12
Loading a preset Acqua Step program	12
Setting the Acqua Step program no. 3 - User	12
INFO menu	13
Holiday menu	14
SPA function	15
Incidental malfunctioning	15
The burner doesn't turn on	15
Shortage of domestic hot water production	15
Boiler inactivity	15
Safety shut off	16
Stand-by mode with anti-frost & anti-locking function	16
"Ambient Anti-Frost" Function	17

---

## Installation

Law and regulation prescriptions for the installer	17
Dimensions and connections	18
Pump capacity diagram	18
Specifications for inlet air	19

Domestic water supply characteristics	19
Protection against freezing	19
Outdoor installation in a partially protected place	20
Positioning and fastening	20
Hydraulic system (DHW and heating)	21
Advices and suggestions to avoid vibrations and noises in the system	21
Cleaning and preservation of the systems	21
Heating system	22
Heating system filling and pressuring	22
Gas connection	23
Electrical connections	23
Closing the boiler casing	24
Flue systems	24
General indications	24
Reducer for short systems	25
Flue terminals positioning	26
Flue system types	27

---

## Adjustment and Maintenance

First starting up	28
Access to the inside of the boiler	28
Inlet gas check	29
PCB parameters settings (technician menu)	29
Main boiler parameters (PC)	30
Max and Min pressure adjustment	30
Max heating power adjustment	31
Burner pressure tables	32
Electronic settings	33
Accessing the main board	33
Main board settings	34
Gas conversion	34
Combustion check	35
Hydraulic settings (pump speed)	36
Draining the heating system	36
Alarms - boiler block	36
Warnings for servicing	41
Technical data	42
Boiler internal components	45
Electrical diagram	46
Hydraulic diagram	47

---

## Addendum

Outdoor Sensor Kit	48
Installation and setting	48
Outdoor Sensor kit and Remote Control	48
Remote Control Kit	49



## Safety warnings





This instructions manual is an essential and complementary part of the product and it is supplied together with the boiler.



Carefully read the manual, achieving all important information for a safe installation, use and servicing.

- ▶ **Carefully keep the manual**, together with the documentation of all the accessories of the boiler and of the system, for any further consultation you may need.
- ▶ **The installation** must be carried out by a qualified technician, in accordance with manufacturer instructions and with the relevant requirements of the current issue.
- ▶ **Carbon monoxide (CO) danger:** the CO is a no-smelling and no-colour gas. When a forced draught boiler with air inlet from the room (appliance type B<sub>2</sub>) is installed, permanent ventilation of the installation room is mandatory and extremely important. Ventilation must be made and sized in compliance with Laws and Rules in force. Whatever manumission, closing or neutralization of the permanent ventilation could lead to very serious consequences to people in the rooms, as intoxication by CO, permanent damage and death. Besides, the CO and O<sub>2</sub> mix can be explosive.
- ▶ A **qualified technician** is a person with a specific technical competence in the field of the heating appliances for domestic use and domestic hot water production, in compliance with Laws and Rules in force.
- ▶ The **operations that the user can do** are only and exclusively the ones contained in the "USER GUIDE" section.
- ▶ The manufacturer has no contractual and extra-contractual responsibility for any damage arising from wrong installation, wrong use and non-observance of current laws and instructions given by the manufacturer himself.
- ▶ **Important:** this gas boiler is used to heat the water at a temperature lower than the boiling one, at atmospheric pressure; it must be connected to an heating system and/or to a domestic hot water system, in accordance with its features and power.
- ▶ Packing items (cartons, nails, plastic bags and so on) **must not be left within children easy reach**, as they are potentially dangerous.
- ▶ **Before any cleaning or servicing operation**, disconnect the boiler from the mains electrical supply by means of the main electrical switch and stop the gas supply by means of the suitable cock.
- ▶ **In case of fault** and/or bad operation of the appliance, disconnect it immediately and do not try to repair it by yourselves.
- ▶ **Boiler servicing and repair** must be carried out exclusively by qualified technicians, which will use original spare parts. Strictly observe the above requirement, avoiding any risk of compromising the appliance safety.
- ▶ **If the appliance should be definitively dismissed**, remove or cut off any potential dangerous item.
- ▶ **When transferring the appliance** (e.g. leaving it installed after a removal or a sale of the building), make always sure that the instructions manual is close to the boiler for the future use of new owners and/or installers.
- ▶ This appliance **must be used for its clearly recommended utilization only**. Any other utilization must be considered dangerous and incorrect.
- ▶ It is strictly forbidden to use the appliance **for different purposes** than the specified ones.
- ▶ This appliance must be **installed exclusively to wall**.

# Safety warnings symbols legend

 Generic safety warning	 Electrical danger (fulguration)	 Physical danger (personal damage)
 Thermal danger (burns)	 General warning or advice to avoid material damage or to achieve improvements	

## References to Laws and Norms

 All the **references to norms and national laws** mentioned in this handbook are indicative as laws and norms are subject to issues and integrations by the authorities in charge. **Also comply to eventual local norms and laws** (not mentioned in this handbook) in force in the territory where the installation takes place.

### *Personnel in charge of installation*

Place here all necessary advices according to national rules about **WORK SAFETY** of Personnel in charge of installation. An example follows:

**Law number 192 of 19-August-2005 and further revisions** “Title of the law or brief description”.



Always proceed with caution when handling the boiler and carrying out installation/maintenance work as metal parts may cause injuries such as cuts and abrasions. **Wear personal protection devices** (especially gloves) while doing the above mentioned operations

### *Installation, use and maintenance*

Place here all necessary advices according to national rules about **BOILER INSTALLATION**, An example follows.

**Law number 412 of 26-July-1993 n°412 and further revisions** “Title of the law or brief description”.

# User warnings

## Important



In case of gas smell:

- 1 - **do not press electrical switches, use the telephone or other objects that can provoke sparks;**
- 2 - **open immediately the windows and the doors in order to cleanse the room air;**
- 3 - **close the gas supply taps;**
- 4 - **call a qualified technician.**



**Do not obstruct the ventilation openings** of the gas boiler room, in order to avoid possible dangerous situations as the creation of poisonous or explosive mixtures.

## First starting up and Use



The first starting up and the maintenance of the boiler must be performed by a professionally qualified staff (for example the installer or the Service Centres authorized by ITALTHERM)

Gas conversion from a gas of a specific family to a gas of another family (from natural gas to LPG or vice versa) to another gas, can be made also when the gas boiler is already installed, but only by a qualified technician. The technician will check that:

- ▶ the label technical data of the gas boiler correspond to those of the gas available;
- ▶ the main burner regulation is compatible with the gas boiler output;
- ▶ the chimney works correctly, expelling the combustion products;
- ▶ the air supply and the combustion products evacuation work correctly, in accordance with the requirements in force;
- ▶ the conditions for a correct ventilation are guaranteed, also when the gas boiler is located inside a closed space (with suitable characteristics).



The User must not touch sealed items nor break the seals. Only specialized technicians and the official technical service can break the seals of sealed items.



The boiler is fitted with a safety flue flow detection device that should never be bypassed or put out of order. If the pressure switch must be replaced, use the original spare part only. In case of repeated interventions of the device (and consequent boiler locks), check that the Air Flue Products Inlet/Outlet System is efficient and made according to the laws in force (see examples in paragraph "Flue systems" on page 24).



When the boiler is off for a long period see the Paragraph "Boiler inactivity" on page 15 for the necessary precautions about the electrical supply, the gas supply and the protection against freezing.



**Do not touch the heated surfaces** of the boiler, as the doors, the flue, the chimney pipe, etc., also after the boiler operation because, for a certain time, these surfaces are overheated. **Any contact with them can cause dangerous scalds.** It is then forbidden to let children or inexperienced people be close to the boiler, during its operation.

- ▶ Do not expose the wall hung gas boiler to water or other liquids sprinklings, or to vapours directly coming from gas cookers/hobs.
- ▶ Do not obstruct the air inlet or flue outlet terminals, even momentarily or partially.

- ▶ Do not put any object on the gas boiler and don't leave any flammable liquid or solid materials, (e.g. paper, clothes, plastic, polystyrene) in its proximity.
- ▶ This appliance is not intended for use by persons (including children) with reduced physical, sensory or mental capabilities, or lack of experience and knowledge, unless they have been given supervision or instruction concerning use of the appliance by a person responsible for their safety. Children should be supervised to ensure that they do not play with the appliance. *(CEI EN 60335-1:2008-07 § 7.12)*
- ▶ If the gas boiler is going to be definitively unused, call a qualified technician to carry out all required operations, checking in particular disconnection of gas, water and electrical supplies.
- ▶ **Only for those models that draw directly from the installation room** (type B appliances installed in-door): the installation of aspirators, fireplaces or similar appliances in the room where the type B appliance is installed (and in adjacent rooms in case of indirect ventilation) is prohibited except in cases foreseen by rules in force and anyway the installation must be made in compliance with all specific safety measures mentioned in the rules and laws in force, even in case of modifications or additions.

## ***Installation, first starting up, maintenance and servicing***

All operations for installation, first starting up, maintenance, servicing and gas conversion **must be carried out by qualified technicians**, in accordance with the Norms and Laws in force.

Maintenance operations must be carried out in compliance with the manufacturer prescriptions, and in compliance with the laws and rules presently in force for what is not mentioned in this handbook; we advise to perform them at least once a year to maintain the boiler's performance.

### ***Appliance booklet or central plant booklet***

All appliances must have an appliance booklet (for outputs less or equal 35 kW) or a central plant booklet (for outputs more than 35 kW). All maintenance and servicing operations and combustion checks must be written on the booklet, together with the name of the person responsible for servicing.

### ***Combustion checking***

Combustion checking consists of a control of the boiler efficiency. Boilers that, after the checking, will have efficiency rates lower than the ones required and not changeable with suitable adjustments (that must be performed by qualified technicians), must be replaced.

### ***Boiler operation and servicing***

The user (owner or tenant of the flat where the boiler is installed) or the administrator of the block of flats (in case of a central heating system) are responsible for the appliance operation and servicing; they can both transfer the responsibility of the servicing and eventually of the operation to another person, which must be a qualified technician as indicated by the Laws. Even if the user or the administrator decide to assume personally this responsibility, ordinary servicing of the warm air heater and combustion checks must be anyway carried out by a qualified technician



## Keyboard buttons

**Note:** the here below keyboard features are referred to the standard way of working. When accessories are installed, a few special settings are in progress or, in case of being in the technician Menu, buttons may perform differently.



### Stand –by/Way of functioning

At every press, the boiler switches its mode from OFF to summer or winter mode.



### CH setting

To set the CH system temperature. If the Outdoor Sensor Kit was installed, see also "Outdoor Sensor Kit" on page 48.



### DHW setting

To set the DHW temperature.

**INFO**

It displays all the additional boiler information. For deeper details go to "INFO menu" on page 13.

**RESET**

Press to reset the boiler in case of breakdown.

See "Alarms - boiler block" on page 36.

**plus**





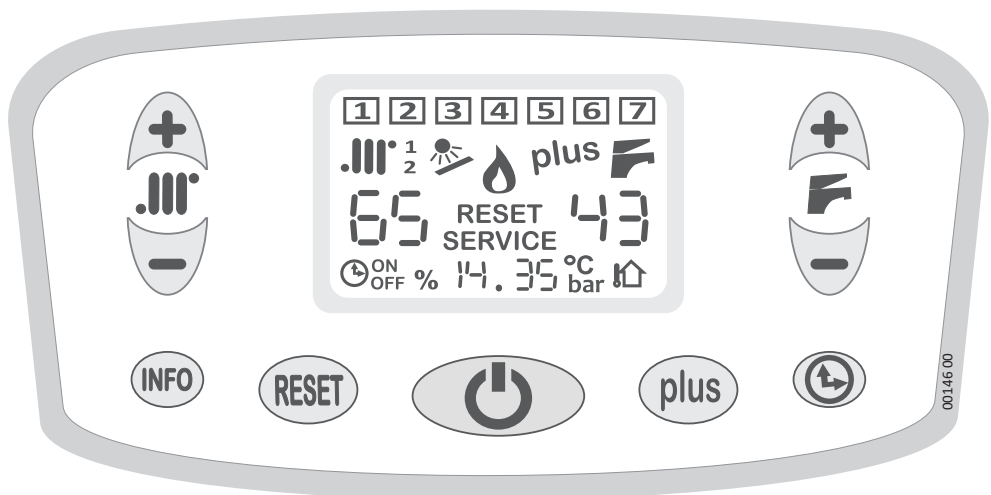

It manually sets the activation, inactivation, and the way of the DHW pre-heating mode.



It sets the hourly setting of the DHW pre-heating mode. It's used also during the programming of the pre-heating function itself and for the setting of the clock.



# Multi-function display

	<p><b>Weekly day</b></p> <p>Shown during the CH setting program. Otherwise, days are showed on the display if the reference function (to make them displayed) is activated.</p>	
	<p><b>CH – winter mode</b></p> <p>If flashing, it means that the boiler is functioning in CH mode.</p>	
<p>1 2</p>	<p><b>CH zone require</b></p> <p>It shows which CH zone is demanding for heating.</p> <p><b>DHW time slot indication</b></p> <p>During the DHW program setting (see "Setting the Acqua Step program no. 3 - User" on page 12) it shows which time slot, among the two available, you are programming.</p>	
	<p><b>Burner ON</b></p>	
	<p><b>DHW Pre-heating</b></p> <p>It means the mode is ON. It flashes when the boiler is working for that.</p>	
	<p><b>Sanitary mode</b></p> <p>It flashes to inform that DHW mode is in process.</p>	
	<p><b>CH temperature</b>, in C° (two digits under the symbol )</p> <p>It usually shows the <b>CH flow</b> temperature.</p> <p>During the CH temperature setting (by pressing the buttons  and ), it shows the <b>temperature value changing</b>.</p>	
<p>RESET or SERVICE</p>	<p>Appears when the boiler is lock (SERVICE or RESET kind of error). See "Alarms - boiler block" on page 36 to understand how to manage.</p>	
	<p><b>DHW temperature</b>, in °C (two digits under the symbol )</p> <p>During the DHW temperature setting (by pressing the buttons  and ), it shows the <b>temperature value changing</b>.</p>	
	<p>It shows the pre-heating mode is ON in scheduled mode.</p>	
<p>ON OFF</p>	<p>It shows, in combination with the symbol , when the DHW pre-heating mode is <b>ON</b> or <b>OFF</b>. This visualization does not mean that the pre-heating mode is in process as if it was, the symbol <b>plus</b> would be flashing.</p>	
<p>%</p>	<p>It appears when the two digits at its right are showing the burner power during the functioning. This information is just available by entering the <b>INFO</b> menu (see "INFO menu" on page 13).</p>	

00147 00



---

**14.35** These four digits (in the middle of the display) show a few information even during the standard boiler functioning: current clock time, CH water pressure, outdoor probe temperature (in case the outdoor probe  is installed). Thanks to the menu **INFO**, others information are available to be displayed. It is even possible to choose the data normally displayed by using the menu (see "Set the display with 4 digits" on page 11; or "INFO menu" on page 13 for other information).

When the boiler is powered but in **OFF** mode anyway, this indicator shows **OFF**.

---

**°C**  
**bar**

They show the unit of measure of the data (shown on the left). If they are switched off, the data may mean the clock time or whatever data different than Bar or °C.



It informs that the outdoor probe (accessories) is installed.

**Note:** *In this case the CH system temperature is automatically set and so the use of buttons **+ .III** and **- .III** is different from the standard way: for deeper details rely on kit instruction and see "Outdoor Sensor Kit" on page 48.*

---

## Commands on the lower side

Besides the commands on the front panel, the **gas cock** is another item that can be used by the user. It is located on the lower side of the boiler, along the gas connection pipe.

It should be opened to allow the gas supply to the boiler and it should be closed any time it's requested to close the gas supply, e.g. when long inactivity periods are foreseen (see "Safety shut off" on page 16) or in any emergency case (see "Important" on page 5).

## Commands outside the boiler

Externally the boiler, suitably positioned in the building (generally by the installer or by the electrician), two devices that the user should access to, are present. The presence and the characteristics of these devices are prescribed by the regulation in force.

**ON/OFF switch:** usually it is installed close to the boiler in order to isolate the boiler from the rest of the whole electrical power system supply.

**Room thermostat:** it commands electrically the boiler to activate or deactivate the heating system, in order to keep the room temperature (detected by a sensor) within a value set by the user, Regulation in force prescribe its positioning, the temperature limits within the user can adjust it and the periods of heating.











**Note:** *ITALTHERM offers (as accessory) a vanguard room thermostat, with weekly set having many levels of temperatures available to be set and other ahead functions. Moreover available, there are two version of this device in GSM and wireless way of functioning.*

# Typical use

## Preliminary operations

- ▶ Be sure the gas cock is opened.
- ▶ Be sure the boiler is electrically powered and set in **OFF**: only **OFF** has to be displayed on the screen.

## Boiler activation









- ▶ Press the button :
  - once to set the boiler in summer mode only (DHW only). Summer mode is recognizable by the only symbol presence  on the display and not by the symbol presence ;
  - pressing twice to set the boiler in winter mode for making the boiler working both for CH and DHW. Winter mode is recognizable by the both symbols presence  and  on the display;
  - at each press of the button , the boiler cyclically switches from **OFF** to summer  and to winter  mode.
- ▶ Opening a DHW tap, the burner fires up, and later then DHW is available. In case pre-heating mode is desired (see "DHW pre-heating mode (Acqua Step)" on page 11).
- ▶ On winter mode  + , when room thermostat demands for heating, the burner fires up and thanks to the water flow the heating get transferred. In case of contemporary demand of both DHW and CH, the DHW demand has the priority till the demand finish. Usually, as DHW does not last for long, this priority does not affect the CH efficiency in the system.

## Temperature adjustment

*Note: correct adjustment leads to creating the conditions for energy saving.*

*Note: if a Low Temperature Kit or an Outdoor Probe Kit are installed, refer to the relevant documentation for what concerns the heating system temperature adjustment.*











*Note: don't make confusion between the heating system temperature  here described, with the temperature of the room set on the Room Thermostat.*

- ▶ **Heating system adjustment:** by using the buttons  and , the setting of the heating system temperature is made (the value, during the adjustment, is shown on the display under the symbol ). Generally, in the deep cold season and/or with poor building thermal insulation (or if you notice that the burner stays on for a long time, but the room temperature rises too slowly) prefer higher settings. On the contrary, if you notice that the room temperature exceeds too much, for thermal inertia, the value set on the room temperature, it's appropriate to decrease the system temperature. **When the optional Outdoor Temperature Probe Kit is installed, the system temperature is automatically managed and the use of the buttons  and  is different: for details, see also "Outdoor Sensor Kit" on page 48.**
- ▶ **Domestic hot water adjustment:** the buttons  and  set the temperature of the hot water produced by the boiler (the value, during the adjustment, is shown on the display under the symbol ). On this type of boiler, we suggest to set it in such a way to have a comfortable hot water temperature by drawing only hot water or eventually by mixing it with a little cold water. Avoid maximum values if not strictly needed, that will force to mix the hot water with bigger quantities of cold water. Consider that, because of the dispersions along the pipings, a certain time is needed to have a stable water temperature on the cock outlet, therefore the best temperature evaluation is achieved during a bath or a shower, and/or activating the DHW pre-heating function (see "DHW pre-heating mode (Acqua Step)" on page 11).

## Hour and day setting

**Note:** after 20 seconds without pressing any button, the function quits without saving.

Daily and hourly set are strictly necessary in case weekly program and holiday menu is desired.

- ▶ press for at least 5 seconds the button  with the boiler in OFF mode;
- ▶ the clock hours will be flashing, thanks to buttons  and  is possible to set the hour time;
- ▶ press the button  and the minutes digit will be flashing. Therefore, adjust the minutes by using the buttons  and ;
- ▶ press the button  and the weekly day  ...  will be flashing. Therefore, adjust the days by using the buttons  and ;

**Note:** for instance, in order to set Monday like first weekly day number 1 (set number 3 in case today was Wednesday).

- ▶ Store the setting and exit the mode by pressing ; for at least 5 seconds.

## Set the display with 4 digits

During the standard function the four digits take place in the bottom side of the screen and can show:

- No indication (choose this if you don't want any indication)
- DHW flow (when there is no DHW request, the value is zero)
- Current time (if the clock hasn't been set yet: no indication)
- CH water pressure
- Outdoor probe temperature (if it is installed - in this case the symbol  is shown, otherwise "-- °C" is displayed)

To choose what data has to be displayed:

- ▶ with the boiler in winter or summer mode (no OFF mode), press the button **INFO** one or more times to toggle among the display modes.

## DHW pre-heating mode (Acqua Step)

A special feature of this boiler is the Acqua Step mode whose advantage is to keep the sanitary water always warmed in order to shortcut the DHW time delivery when required. This allows to shortcut the waiting time and the water waste.



Thanks to the insulated material the DHW exchanger is wrapped of, the boiler **reduces** the heating losses and so gets an **optimized consumption of gas in comparison with the traditional boilers** (especially during brief and frequent DHW withdrawals).

It is possible:

- to set the pre-heating mode on three different levels (the steps) of temperature;
- activate or inactivate Acqua Step manually;
- automatically activate and inactivate Acqua Step mode on hourly and weekly bases.

**Note:** if the clock has not been set yet (see "Hour and day setting" on page 11) any functions that foresee automatic scheduling cannot be set.

## To set the desired "step"

- ▶ The boiler must be set in OFF mode, and press the button **plus** for at least 5 seconds;
- ▶ the display shows the symbols **plus** and . Below them, a value number (from 1 to 3) appears which means what Acqua Step level you can choose; (1=normal pre-heating, 2=high pre-heating, 3=maximum pre-heating);
- ▶ Thanks to the buttons **+** and **-** it is possible to choose the desired step. Then press the button **plus** for at least 3 seconds to store the choice.

*Note: The choice applies both the manual and the scheduled activation.*

-  If hard water is present, it's recommended to use the step no. 1. The step 3 can be used only if the water has low scale content or if it's processed this way.

## Manual set of Acqua Step

- ▶ The boiler must be set in winter or summer mode (no OFF mode) and press the button **plus** for activating or inactivating the mode. When it's activated, the symbol **plus** appears on the display.

## Loading a preset Acqua Step program









*Note: after 20 seconds without pressing any button, the function quits without saving.*

It is possible to load an Acqua Step program among three available: two are permanently factory-preset; the third can be personalized by yourself as described further on.

**Program 1:** ON MON÷FRI 06:00÷09:00 and 17:00÷21:00; SAT÷SUN 06:00÷10:00 and 16:00÷21:00









**Program 2:** ON all days 06:00÷10:00 and 16:00÷21:00

**Program 3: user-customizable program** (on a new boiler, it's factory set same as program 1).

- ▶ The boiler must be set in winter or summer mode (no OFF mode), and press the button  for at least 5 seconds: the display shows the current program number (P1, P2, P3), on the right;
- ▶ choose the suitable program by buttons **+** and **-** and press  to load it;
  - choosing **P3** (custom program) the relevant data appear on the display: now it's possible to edit it as described in "Setting the Acqua Step program no. 3 - User" on page 12 or you can simply load it as it is by pressing  for at least 5 seconds;
- ▶ at this point, the boiler switches back to winter or summer mode. To make Acqua Step function work scheduled, press : on the display should be visible the symbol ON (or OFF depending on the state of the current time slot).

## Setting the Acqua Step program no. 3 - User

*Note: after 2 minutes without pressing any button, the function quits without saving.*

1. Determine one or two time slot, for every day of the week, in which Acqua Step mode is thought to be automatically required. Daily and hourly set can both be the same or different day by day.
2. set the boiler in winter or in summer mode (not in OFF) and press  for at least 5 seconds;
3. choose the program **P3** using **+** and **-** and press  to load it;
4. the display shows the current day (e.g. the day **1**), a little number "**1**" on the upper-left part, the symbol ON and a time, meaning that currently the **activation** of Acqua Step function, on the **first time slot** of the **first day**, is scheduled on that time;
5. press the button  for entering in the timer setting, that starts blinking;
6. use the buttons **+** and **-** for modifying the **starting time** of the **first time slot** of Acqua Step activation (10 minutes steps), and then press **+.**;

**Note:** timings are stored exclusively by pressing the button **+ .III**. Besides, this will position the programming on the following event.

7. the symbol **OFF** as well as another time appears, which means that the first **deactivation** is set on that time;
8. press **⌚** (the time blinks); use the buttons **+ F** and **- F** for modifying the **ending time** of the **first time slot** of Acqua Step activation (10 minutes steps), and then press **+ .III**;
9. the display now shows a little number "2" on the upper-left part, the symbol **ON** and a time, meaning that you are programming the **second time slot** of the Acqua Step function, of the same day. Proceed in the same way as you just did for the first time slot;
10. after the last press of the button **+ .III** the day 2 is selected and you can set it as described for the day 1; otherwise you can **copy** the day 1 schedule on the day 2 as follows:
  - return to day 1, already programmed, using the button **- .III**. Then, press the button **INFO** for 5 seconds: the symbol of the day 2 will be flashing;
  - press **⌚** to confirm the copy of the day 1 on the day 2 and skip to this latter;
  - similarly, to copy the program to the further day 3 after (and so on), it's sufficient to press the button **INFO** for 5 seconds, and press **⌚** to confirm the copy.
11. press the button **⌚** for at least 5 seconds to exit and return in winter or summer mode as at the beginning.



<b>+ .III</b>	<b>TIME SLOT or DAY</b>
<b>-</b>	<b>forward - backward</b>
<b>+ F</b>	<b>TIME</b>
<b>- F</b>	<b>increase - decrease</b>

## INFO menu

It is possible to get a few information displayed on the screen as far as regards the boiler functioning which can be showed on some different screen pages. Usually they are useful for the Technician only. Anyway, even the user can look at them without affecting the good working of the boiler.

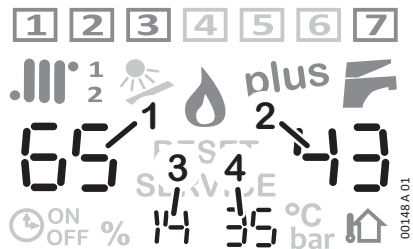
- ▶ With the boiler in winter or summer mode (no OFF mode), press the button **INFO** for at least 5 seconds;
- ▶ the display will show the **page 1** (information about the **current work** in progress):
  - **1** ... **7**: boiler cycle in progress (technician reserved information)
  - **.III** heating mode ON, **F** DHW ON: shown symbol = available function; if flashing, the mode is in progress; **1** activated zone(s), **plus** Acqua Step pre-heating mode,
  - **🔥** = Burner ON
  - indicator number **1**: CH system flow temperature in °C (measured)
  - indicator number **2**: DHW temperature in °C (measured)
  - indicator number **3**: burner power in % from 0 to 99 (0 = minimum)
  - indicator number **4**: (not used)
- ▶ press the button **+ .III**: to get to the **page 2** (information about the **boiler settings**):
  - **.III** heating, **plus** Acqua Step pre-heating, **F** DHW: they support the numeric indications;
  - indicator number **1**: Primary CH flow (set temperature). If outdoor probe **🏠** is installed, ignore this value;





- indicator number **2**: DHW temperature (set temperature)
  - indicator number **3**: Secondary CH flow (set temperature)
  - indicator number **4**: chosen Acqua Step level
- ▶ Press the button **+ .III°**: the display shows the page **3**: information which are referred to the **thermoregulation** (if the outdoor probe  is installed only).
- **.III°** CH system,  $\frac{1}{2}$  zone/s,  outdoor probe: they support the numeric indications.
  - indicator number **1**: CH flow temperature to the primary zone (shown when the request is on). The temperature is calculated on the base on the outdoor probe temperature according to its **kd** curve setting
  - indicator number **2**: outdoor probe **kd** curve number
  - indicator number **3**: CH flow temperature to the secondary zone (shown when the request is on). The temperature is calculated on the base on the outdoor probe temperature according to its **kd** curve setting
  - indicator number **4**: Outdoor temperature felt by the outdoor probe. If the value is **-9°C** it means that the outdoor temperature is 9° C below 0° or even lower.
- ▶ Pressing the buttons **+ .III°** and **- .III°** it is possible to turn the pages onward or backward;
- ▶ Press the button **INFO** to exit the INFO menu. Anyway, after 15 minutes the boiler automatically exits the menu.

## Holiday menu

**Note:** *if the clock has not been set yet (see "Hour and day setting" on page 11) this function cannot be used.*

The user can decide to keep the boiler on OFF mode as many days as he wants. After that, the boiler automatically returns in winter mode (or, if the optional Remote Control is installed, this latter returns in the mode it was in the moment of the activation, while the boiler returns in Summer mode to allow the correct work of the Remote Control).



- ▶ The boiler must be set on OFF mode (not in winter or summer mode), and press the button  for at least 5 seconds;
- ▶ on the left side of the display the symbol  and "Ho" will appear as well as on the right side a value number;
- ▶ press the buttons **+ F** and **- F** to set the number of inactivity days (don't include the current day);
- ▶ press the button  for at least 3 second to save the setting. From now the Holiday function is ON and will expire at 23:59:59 of the last day.

**Note:** *afterwards, it is possible to set the boiler in modes different from OFF, but the Holiday function will operate only if the boiler is set to OFF.*

## SPA function

**Note:** if the optional Remote Control is installed, this function can only be managed by it.

This function is useful, in example, when a bath tub has to be filled. It forces the DHW temperature to the maximum for **30** minutes, then the function deactivates automatically.

- ▶ With the boiler in winter or summer mode (no OFF mode), press the button **plus** for at least 5 seconds;
- ▶ on the central, lower side of the display, the indication "SPA" appears, and the digits below the symbol  blink;
- ▶ to deactivate the function before, press one of the buttons **+ ** or **- **.

## Incidental malfunctioning





**Avoid performing personally any intervention that are job of the technician, for example the ones on the electrical circuits, on hydraulic system or on the gas system, and whatever other operation that's not mentioned in this "User Guide" section and expressly allowed to the User. Always address yourselves to qualified personnel.**

**Boilers must be always equipped with original accessories only.**

**ITALTHERM Srl is not responsible for damages caused by the incorrect, wrong or unreasonable use of not original materials.**

### *The burner doesn't turn on*

- ▶ if the room thermostat (or programmable room thermostat, or similar) is installed, check that it is really requiring the room heating;
- ▶ Be sure the boiler is set on winter  +  or summer  mode (not in **OFF**). The reference symbols must be shown on the display (see "Multi-function display" on page 8);
- ▶ In case the display shows **RESET** or **SERVICE**, or in case the boiler seems to be working in an inappropriate way, see "Alarms - boiler block" on page 36;
- ▶ check the CH pressure is correct (1÷1.5 Bar **in a cold state**) or anyway **not lower than 0.5 Bar**;

### *Shortage of domestic hot water production*

- ▶ check the DHW temperature is not set on a too low value: if so, adjust it (see "Temperature adjustment" on page 10);
- ▶ call a qualified technician to check gas valve regulation;
- ▶ call a qualified technician to check, and eventually clean, the DHW exchanger.



Remark: where the water hardness value is too high, it is suggested the installation of a softening device, in order to prevent the limestone precipitation; this operation avoids a frequent cleaning of the coil.

## Boiler inactivity

The effects of the periods of inactivity can be relevant in particular situations such as in flats used only for some months per year, most of all in cold places.

The user will have to decide to put the boiler in the **SAFETY SHUT OFF state** disconnecting all the supplies, or to **leave it on OFF mode (but electrically supplied) in order to let the Anti Frost Function work**. When there is the possibility of freezing it is convenient to chose between the advantages and the disadvantages of the SAFETY SHUT OFF and of the Stand By/Anti Freezing Way.

## Safety shut off

- ▶ Turn off the general switch on the Electrical Supply Line of the Boiler;
- ▶ Close the Gas Tap;

**(i)** When it is expected that the temperature is going to decrease under 0°C, call a technician to do the following:

- Fill the system with an anti-freezing solution (unless the system was already filled with said solution) otherwise it must be completely emptied. Notice that if it had been necessary to restore the pressure (because of possible loss) in an heating system already filled with an Anti freezing solution, the concentration of the solution could have decreased and it could not guarantee the Anti freezing Protection.
- completely empty the hot and cold sanitary water system, including the sanitary circuit and the boiler's sanitary exchanger.

**Remark:** *the boiler is equipped with a system which protects the main components from the exceptional cases of mechanical lock, due to the inactivity in presence of water and scale. The anti-locking function can't work in Safety shut off mode, because of the lack of electrical supply.*

**(i)** Before re-igniting the boiler, have a technician check that the pump is not blocked due to inactivity (for the technician: unscrew the plug in the centre of the cap to access the rotor shaft and turn it with a screwdriver or other suitable tool).

## Stand-by mode with anti-frost & anti-locking function

When the boiler is left in **OFF** mode during a period of inactivity, it will be protected against freezing by several functions provided in the electronic controller, which heat the parts involved when the temperature falls below factory set values.

The anti-frost heating is accomplished by turning on the burner and pump.

In addition, when the boiler is in stand-by, it periodically activates the main internal components to avoid rare cases of blockage due to inactivity in the presence of water and lime. This can also occur when the boiler is locked (red lamp on) provided that the system pressure is correct.

In order for these systems to be active:

- the boiler must be receiving gas and electricity;
- boiler must be left on **OFF** mode (OFF shown on the display);
- system pressure must be correct (1÷1.5 bar in a cold state, minimum 0.5 bar)

In case of lack of gas, the burner won't turn on and the boiler will go in LOCK OUT state (red lamp on or flashing). Nevertheless the pump will work, making the water circulate in the system and reducing in this way the possibility of freezing. *It is available, on demand, an Anti Frost Electrical resistance kit which must be installed on the secondary exchanger to protect the boiler also in case of lack of gas.*

**(i)** **ATTENTION:** the anti-frost protections cannot intervene in the absence of electricity. If you anticipate this possibility, we recommend you add a good brand of anti-freeze to the heating system, following the producer's instructions.



**We recommend to ask directly the installer/technician about the type of antifreeze product put in the heating system during installation.**

When the power comes back on, the boiler will check the temperature measured by the two probes and, if it suspects freezing verified by a particular automatic control cycle, alarm 39 will be triggered. For more details, see the relative description in the paragraph "Alarms - boiler block" on page 36.



**(i)** We recommend that you completely empty the hot and cold sanitary water system, including the sanitary circuit and the boiler's sanitary exchanger. The anti-frost function does not protect the sanitary circuit outside the boiler.

### **“Ambient Anti-Frost” Function**

**Note:** if you want to use the “Ambient Anti-Frost” function that is often available in common room thermostats or chronothermostats, it is necessary to leave the boiler on Winter  +  mode and NOT on OFF mode.

**(i)** The “Ambient Anti-Frost” function does not protect the sanitary circuit outside the boiler and, especially, in areas where the heating system doesn't reach. For this reason, we recommend that you empty the cold and hot sanitary water from the parts of the system that are at risk of freezing.



## **Installation**

### **Law and regulation prescriptions for the installer**

**Note for the translator/writer:** Place in this paragraph all the recommendations relevant to the compliance with laws in the destination nation/country (if any). As an example (from Italian regulation):

**Characteristics of the room:** as this boiler has an heat output lower than 35 kW (about 30000 Kcal/h), it is not required to install the appliance in a dedicated room, provided that the room complies with the regulation in force and that all installation rules assuring a safe and regular gas boiler operation, are strictly respected.



**Permanent ventilation of the installation room is mandatory and extremely important** when a boiler with air draught from the installation room (B... appliance type) is installed. Ventilation must be made and sized in compliance with Laws and Rules in force.

**Instructing the user:** at the end of the installation, the installer must:

- explain the operation of the boiler and its safety devices to the user;
- give this user this booklet and the documentation within his/her competence, duly filled in where required.

# Dimensions and connections

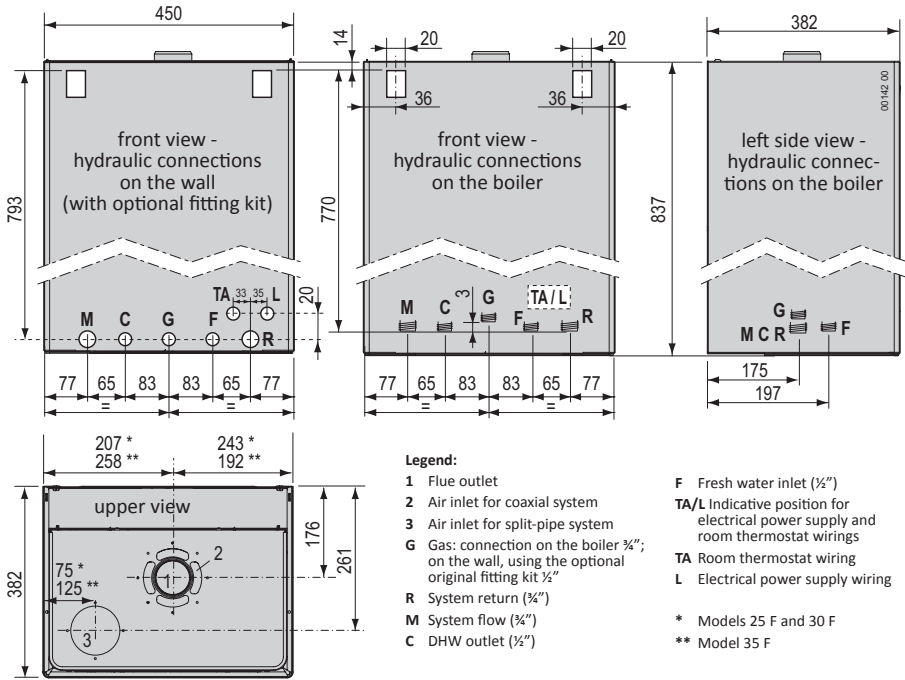

# Pump capacity diagram

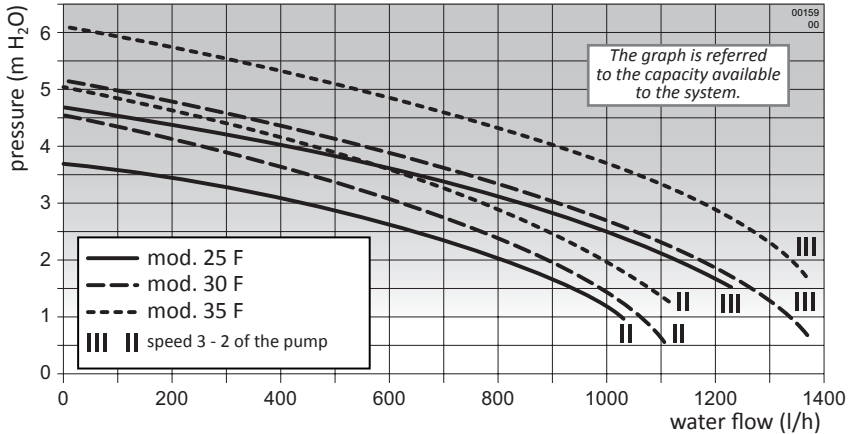

## Specifications for inlet air

Air must be withdrawn from places free of pollutant (like fluorine, chlorine, sulfur, ammonia, alkaline or similar agents). In the event of installation of the boiler in atmospheres with not negligible presence of aggressive chemical substances (e.g. hairdressing salons, laundries) we recommend to foresee the air inlet from outdoor, choosing the type C installation.

## Domestic water supply characteristics

**The cold water inlet pressure must be lower than 6 Bar.** Besides, for an optimal boiler functioning, water pressure **should be more than 1 Bar.** A lower pressure could make difficult to restore correctly the pressure the heating system, and reduce the flow of hot water available from the boiler.

**(i)** In case of higher pressure **it is indispensable to install a PRESSURE REDUCER** upstream the boiler.

**The cleaning frequency of the DHW heat exchanger depends on the water supply hardness.** If the water hardness is more than 25° fr it's required to install a softener to bring the hardness below that value.

Besides, the presence of solid residuals or impurities in the water (for example in case of new systems) could compromise the correct functioning of the boiler. For DHW production systems, the regulation in force prescribes a safety filter to protect the systems.

## Protection against freezing

Thanks to its antifreeze system, inner components could never reach a temperature lower than 5°C. This system is activated when the boiler is supplied by the electrical and gas lines, provided that the pressure in the heating system is correct. *On request, it is possible to install an antifreeze electrical resistance device on the domestic exchanger, so as to protect boiler even in case of gas lack.*

**(i)** In case of boiler installation in rooms where temperature can drop down to 0°, it is advisable to fill the heating circuit with an antifreeze liquid specific for heating systems, propylenic glycol based, following the instructions of its manufacturer. Pay attention to the correct product concentration: adding those substances to the heating water in incorrect dose could lead to the deformation of the seals and cause unusual noises during operation.

ITALTHERM S.r.l. will not be held responsible for consequent damages.

**Instruct the User about the antifreeze function of the boiler and about the antifreeze product added in the heating system.**

# Outdoor installation in a partially protected place

"F" forced draught models can be installed outdoor, but only in partially protected places.

The boiler minimum and maximum working temperatures are mentioned in the paragraph "Technical data" on page 42 and on the boiler data plate.

The materials used for the boiler installation, including the devices and/or the materials used for thermal insulation, should be so to **maintain their functionality** within the temperature range indicated on the data plate.



If the place where the boiler is located is converted from outdoor to indoor (e.g. veranda) it will be necessary to **verify the compliance** of the new configuration with the laws and rules in force, and to make the modifications required.

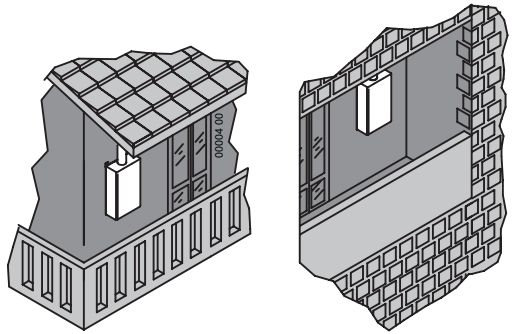

## Positioning and fastening

**Remark:** A re-usable metal jig (D in the figure) can be ordered separately, so as to facilitate connections and fixing points positioning (when the original connection kit is used). **If the metal jig and/or the original connection kit are not used, refer to the paragraph "Dimensions and connections" on page 18 for the position of the connections directly on the boiler.**

- ▶ Locate the exact position of the boiler considering the sufficient clearances for maintenance and servicing: at least 50mm laterally and 300 mm on the lower side
- ▶ Place the support devices on the wall, matching the openings B.
- ▶ If the metal jig is used, hang it on the wall using the same support devices and the openings B indicated in the figure.

<b>GAS</b>	Gas (1/2")
	Hot Water Outlet (1/2")
	Cold Water Inlet (1/2")
	Heating Flow (3/4")
	Heating Return (3/4")
	Electrical Power Supply
<b>TA</b>	Room Thermostat

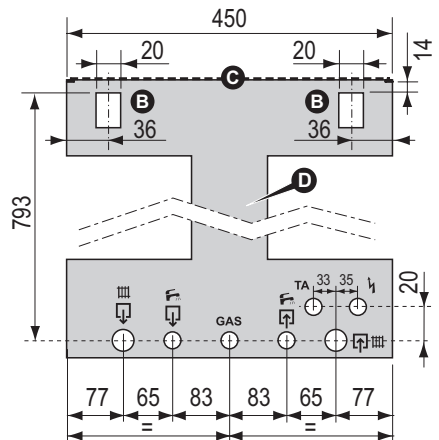
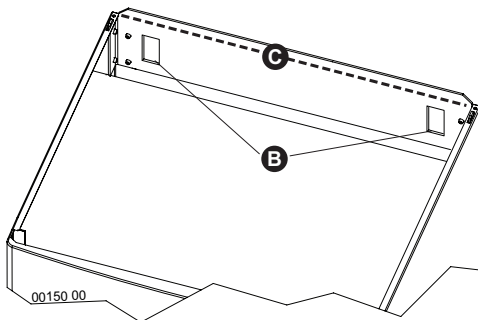

- ▶ Fix up the connections and all ducts for heating flow and return, cold water, hot water, gas and electrical cables, predisposing them in the holes of the metal jig or respecting the measures in the paragraph "Dimensions and connections" on page 18. The upper edge of boiler's body, used as a reference in the paragraph "Flue system types" on page 27, is represented by the dotted line **C** in the figure.
- ▶ Remove the jig (if used) and hang the boiler to the support devices, by the openings **B** indicated in the figure.

**(i)** **Remove, from the boiler, all the styrofoam reinforcements, and the plastic caps** placed to close the hydraulic connections.

- ▶ Proceed with the hydraulic, gas, electrical and flue connections following the instructions and warnings reported in the following paragraphs.

**(i)** The connections of the boiler are engineered to fit plain couplings with screw ring, interposing a plain gasket of suitable size and material, that ensure a reliable seal even without excessive tightening force. They are NOT suitable for hemp, teflon tape or similar materials

*Remark: the lower grid is spare inside packing, not assembled. We suggest to fix the grid only at the end of the boiler installation operations.*

## Hydraulic system (DHW and heating)



Make sure that the hydraulic and heating systems ducts **are not used as earth connections of the electrical system**. They are absolutely NOT SUITABLE for such a use. Besides: they don't guarantee the earth dispersion; in case of electrical fault they could generate a fulguration risk; there could take place galvanic currents in the pipings and consequent corrosion and hydraulic leaks.

### *Advices and suggestions to avoid vibrations and noises in the system*

- ▶ Do not use pipes with reduced diameters;
- ▶ Do not use bends with small radius and reductions of important sections.

### *Cleaning and preservation of the systems*

The efficiency, the reliability and the safety of the boilers, as all generic thermal systems and components, depend strictly on the features of the water that supply them and on their treatment.

A proper treatment of the water improves the protection of the systems against corrosions (and therefore perforations, noise, leaks, etc.) and limestone incrustations that drastically reduce the efficiency of the thermal exchange (consider that 1 mm of limestone incrustations reduces of 18% the thermal exchange of the heating element on which it has been formed).

ITALTHERM guarantees its products only if the characteristics of the water comply with UNI 8065, reported also in laws on energy saving.

**(i)** Thoroughly wash the heating system with water, before connecting the boiler. This will eliminate residual like welding drops, slag, hemp, mastic, mud, rust and other dirt from pipes and radiators. Otherwise, these substances could enter the boiler and damage the internal components (pump etc.).

- ▶ **In case of old or very dirty systems, to wash them use specific, proven efficiency products**, in the suitable quantity and following the instructions of its manufacturer.
- ▶ If the water on boiler inlet is harder than 25° fr, it's required to install a softener to bring the hardness below that value, as required by the reference regulation.
- ▶ For floor system and generally all low temperature systems, the water treatment product must have filming action (protection against corrosion and incrustation) and action against bacteria and algae.

## Heating system

- ▶ Connect the safety evacuation ducts of the boiler to an evacuation funnel. If safety valves are not connected to an evacuation device, their intervention could flood the room. The manufacturer cannot be held responsible for any damage arising from that situation.

## Heating system filling and pressuring

Once all system connections have been carried out, proceed with system filling. This operation should be made with care, respecting the following steps:

**(i)** During this operation, the boiler should not be electrically supplied.

If the boiler is supplied, an automatic system filling cycle will start. If the system is empty, this operation will be incorrectly performed and it will cause, uselessly, many boiler blocks.

- ▶ Open the radiators venting devices;
- ▶ Check that the plug of the automatic air vent, incorporated in the boiler circulator, is unscrewed: if not, unscrew it and leave it unscrewed, even afterwards, for normal operation;
- ▶ If it's required to fill the system with anti-freeze solution, do this operation, then hermetically close the connection or the valve used to put the solution in, to allow the pressurization.
- ▶ Slowly turn the screw **1** on the filling electrovalve, from position "**C**" to position "**A**" (see picture);
- ▶ Check the correct functioning of automatic venting devices, eventually installed;
- ▶ Close the radiators venting devices as soon as water flows out of them;
- ▶ Make sure, by reading the pressure gauge **2**, that the pressure reaches the optimal value of **1.0 bar (max 1.5 bar)**;
- ▶ Turn the screw **1** on the filling electrovalve, to position "**C**" and bleed each radiator again;
- ▶ Repeat the venting and pressurization operations until the air is completely purged from the system.

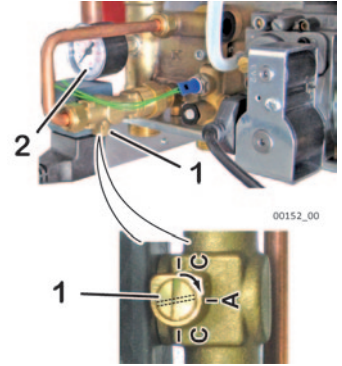

## Gas connection

Due to various installation possibilities, the gas cock **3** supplied with the original Connections Kit has a simple male  $\varnothing \frac{1}{2}$ " connection, facing the rear of the boiler. *The gas pipe 4, upstream the gas cock 3, should be supplied by the installer.*



**While connecting gas inlet pipe of the boiler to the pipe coming from gas network, it is MANDATORY to insert a PLAIN GASKET, whose dimensions and material must be adequate. Connection is NOT suitable for hemp, teflon strip or similar materials. Because of the type of fitting, the use of those materials does not make the suitable seal with consequent gas leaks!**



**Using LPG, it is absolutely necessary to install a pressure reducer upstream the boiler. Failure to do this, the gas valve of the boiler will get damaged.**



The gas connection, as generally the boiler installation, must be done by qualified personnel as prescribed by the regulation in force, because a faulty gas connection could lead to fire, explosion and other very serious damages to persons, animals and objects. The manufacturer cannot be held responsible for any damage arising from that situation.

### ► Verify what follows:

- cleaning of all system gas pipes in order to avoid the presence of work residuals that could compromise the correct boiler functioning;
- gas line and ramp conformity with laws and rules currently in force;
- internal and external tightness of the gas system and connections;
- supply pipe must have a section greater than or equal to the boiler one;
- supply gas must correspond to the one for which the boiler has been set: otherwise, it's mandatory to ask to qualified personnel to set the boiler for the correct gas type;
- an interception valve must be installed upstream the appliance.

► Open the meter valve and purge the air that is inside the system pipes (including all the appliances).

## Electrical connections



The link of the room thermostat works with a safety extra low voltage (SELV); connect it to the voltage free contacts of the room thermostat/chronothermostat. **On NO account must any electrical voltage be applied** to these terminals.



All low-voltage wirings (e.g. Room Thermostat or Chronothermostat for trade) must be kept separate from power supply cables, as to avoid boiler malfunctioning due to electrical noise. It is advisable to use separate tubes for them.

The boiler must be connected to a 220÷240V - 50Hz electrical power supply. In any case, the power supply voltage must be within the range  $-15\% \dots +10\%$  from the nominal value (230V); otherwise it may cause malfunctions or failures. It is necessary to respect the polarities L-N (Live L=brown; - Neutral N=blue) - otherwise the boiler may not work - and the earth connection (yellow-green cable).



**Place upstream the boiler a bipolar switch** in compliance with the regulation currently in force. The installation must be made complying the regulation currently in force and generally with the standard craft rules.

For the general electrical supply of the appliance the bipolar switch should be used. The use of adaptors, multiple taps and extensions is not allowed.

If the supply cable must be replaced, use one of the following cable types: H05VVF or H05-VVH2-F.



The supply cable replacement must be done by qualified personnel.

**It is mandatory the earth connection in accordance with the rules actually in force.** To replace the cable, open the control panel cover, unlock its fastening device and disconnect it from the terminals. Install the new cable proceeding in the reverse way. When connecting the cable to the boiler, it's mandatory:

- to leave the Earth wire about 2 cm longer than the other (Live and Neutral) wires;
- to lock the cable upstream the terminals by means of the suitable fastening device.



Electrical safety of the appliance is only achieved when it is well connected to an efficient earthing system, executed as indicated by the safety rules actually in force.

A qualified technician must check that the electrical system is in line with the maximum power allowed by the boiler, indicated on the data plate, with particular attention to the cables section.



ITALTHERM S.r.l. declines any responsibility for damages to persons, animals or things caused by the faulty or missing connection of the boiler earthing and by failure to comply with the rules.

## Closing the boiler casing

At the end of the installation, after having replaced the front panel **4**, lock it by means of the stop plates **2** and the screws **1**, bulk-supplied in the boiler's spares envelope.



The plates must be installed to comply regulation in force.

Tongues **3** should match the internal edge of the panel and the screws **2** should be tightened slightly after having positioned the plates towards the front, so as to avoid that the front panel slides upwards and un-hooks.

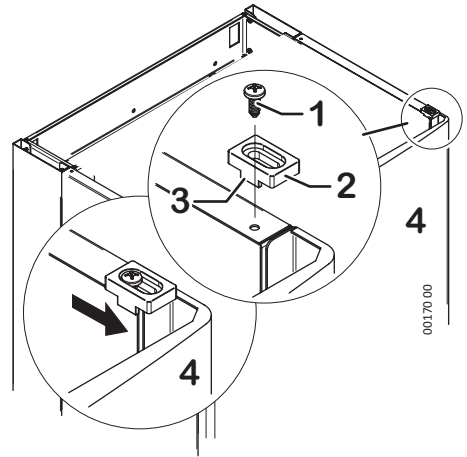

## Flue systems

### General indications

To ensure the functionality and the efficiency of the appliance it is necessary to foresee, **for the horizontal ducts** of air inlet and flue outlet, a slope of 2÷5% downwards **from the boiler to the outside** (see diagram).

In the case of **vertical flue** outlet duct, to avoid condensation reflux in the sealed chamber, **it is necessary to use a suitable condensate collection kit**.

Air inlet and flue outlet terminals should be protected by suitable approved flue accessories, to avoid environmental elements penetration.

**Don't lean the flue pipe into the chimney, but stop it before the inner surface of the chimney. The axis of the flue pipe must intersect the axis of the chimney or of the flue duct.**



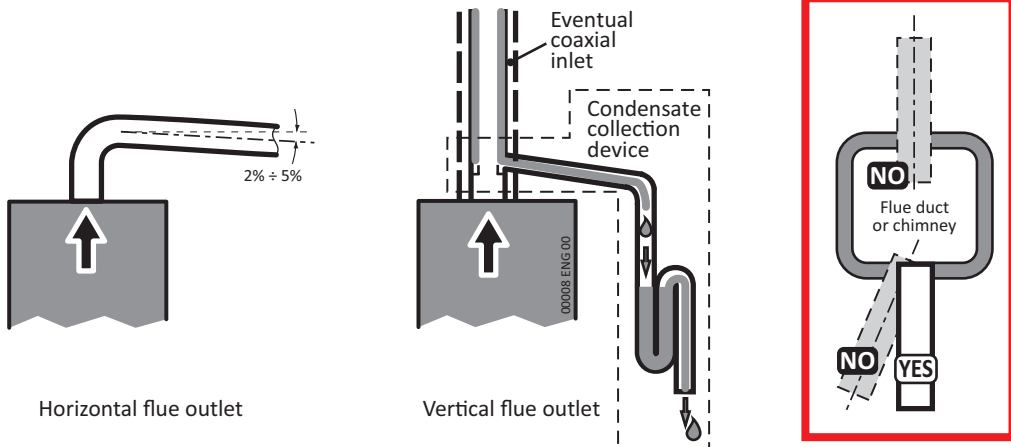

Carefully follow the prescriptions by the National and Local Regulation in force.

Respect the minimum and maximum flue system length (refer to "Flue system types" on page 27).

In case of flue outlet on wall, the positions and the distances prescribed by the regulation must be respected (see "Flue terminals positioning" on page 26).

### Reducer for short systems

In case of short air inlet and flue outlet systems, to achieve the correct combustion, the installation of a suitable flue diameter reducer could be necessary. The reducer that fits most cases is supplied with the boiler. In a few particular cases, it could be necessary a different reducer, optional, to be ordered by mentioning its inner diameter or the relevant spare part number (see technical literature). Indications about the use of the reducer (and the relevant diameter, for the optional reducer), on the basis of the flue system type and length, are contained in the paragraph "Flue system types" on page 27

**(i)** Referring to the tables, calculate the equivalent linear length considering every additional bend installed (exclude the ones shown in the diagrams) and, if required, install the reducer **D** as shown in the figure.

**(i)** Comply with the regulation in force when installing the flue systems.

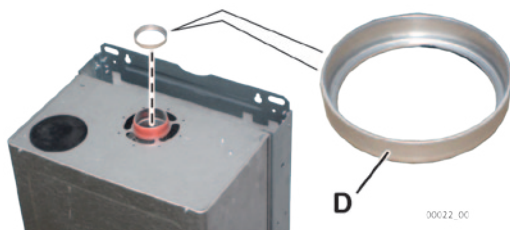

## Flue terminals positioning

Posizionamento dei terminali di scarico (nella parete stessa di cui si sta valutando la zona di rispetto) per apparecchi muniti di ventilatore in funzione della loro portata termica (per informazioni dettagliate, vedere la norma UNI 7129-3:2008 e successive modifiche o integrazioni)

Posizionamento del terminale	Quota	Distanze minime (mm)		
		Apparecchi da 4 kW fino a 7 kW	Apparecchi oltre 7 kW fino a 16 kW	Apparecchi oltre 16 kW fino a 35 kW
Sotto finestra	A1	300	500	600
Adiacenza ad una finestra	A2	400	500	400
Sotto ad una apertura di aerazione/ventilazione	B1	300	500	600
Adiacenza ad una apertura di aeraz./ventilaz.	B2	600	600	600
Distanza in verticale tra due terminali di scarico	C1	500	1000	500
Adiacenza in orizzontale ad un term. di scarico	C2	500	800	1000
Sotto balcone	D1	300	300	300
Fianco balcone	D2	1000	1000	1000
Dal suolo o da altro piano di calpestio	E	400 ***)	1500	1200
Da tubazioni o scarichi verticali od orizzontali **)	F	300	300	300
Sotto gronda	G	300	300	300
Da un angolo/ventranza/parete dell'edificio	H	300	300	300

\*) I terminali sotto un balcone praticabile, devono essere collocati in posizione tale che il percorso dei fumi dal punto di uscita del terminale al loro stop da perimetro esterno del balcone, compresa l'altezza dell'eventuale parapetto di protezione (se chiusa), non sia minore di 2000 mm. Per una corretta computazione del percorso dei fumi vedere la norma UNI 7129-3:2008.

\*\*\*) Nella collocazione dei terminali devono essere adottate distanze non minori di 500 mm da materiali sensibili all'azione dei prodotti della combustione (per esempio, gronde e pluviali di materia plastica, elementi sporgenti di legno, ecc.); per distanze minori adottare adeguate schermature nei riguardi di detti materiali.

\*\*\*\*) In questi casi i terminali devono essere opportunamente protetti per evitare eventuali contatti diretti con persone.

Nota: Non è consentito scaricare a parete con terminale collocato all'interno di un balcone chiuso su 5 lati (vedere la norma UNI 7129-3:2008). Il terminale dovrebbe sporgere oltre il balcone con però la computazione delle distanze di cui sopra.

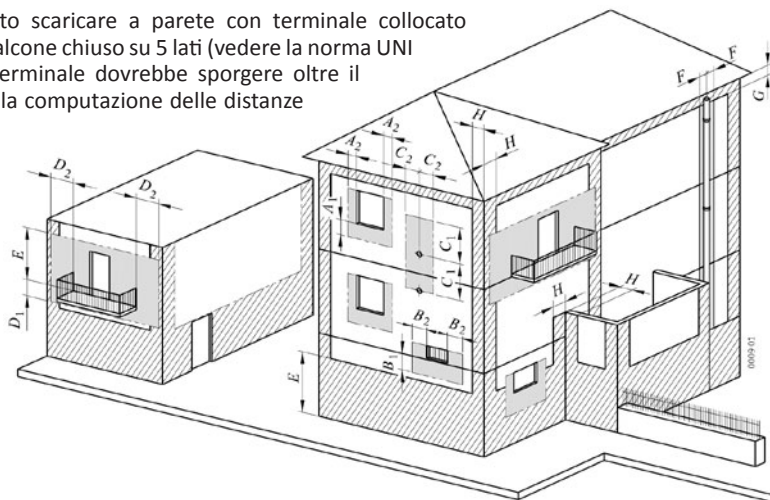

# Flue system types

## Split pipe system (C<sub>42</sub>, C<sub>52</sub>, C<sub>82</sub>, C<sub>92</sub> \* and B<sub>22</sub>)

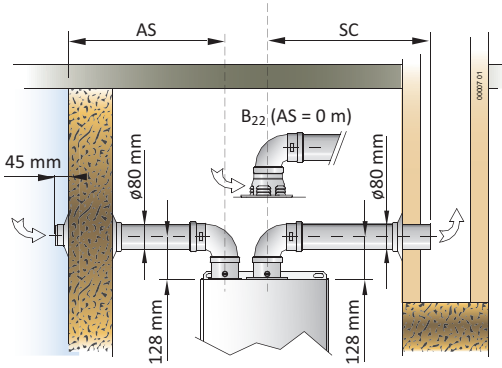

Example of split pipe system (C<sub>82</sub>)

a 90° Ø80 bend equivalent length is 0,5m  
 a 45° Ø80 bend equivalent length is 0,25m

Model	Split pipe system Ø80mm			
	AS+SC min÷max (m)	SC max (m)	Reducer	
			for length of AS+SC (m)	Ø mm
25 F	2 ÷ 28	20	up to 8	46 (R)
			more than 8	NO
30 F	2 ÷ 16	10	up to 8	48 (R)
			more than 8	NO
35 F	2 ÷ 20	12	up to 8	48 (R)
			more than 8	NO

Ø80mm type B <sub>22</sub> system (AS=0m) made by adapter on coaxial connection				
25 F	1 ÷ 20	20	up to 8	46 (R)
			more than 8	NO
30 F	1 ÷ 9	9	always	48 (R)
			always	48 (R)
35 F	1 ÷ 9	9	always	48 (R)

(F): the reducer is supplied with the boiler  
 (R): the reducer is available on request  
 the diameter is punched on the reducer itself

\* Note: Split pipes allow to make also C<sub>12</sub> and C<sub>32</sub> flue systems

## Coaxial system (C<sub>12</sub>, C<sub>32</sub>)

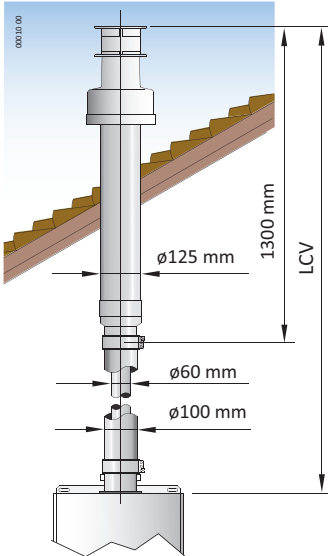

Example of vertical coaxial system (C<sub>32</sub>)

a 90° Ø60/100 bend equiv. length is 1,0m  
 a 45° Ø60/100 bend equiv. length is 0,5m

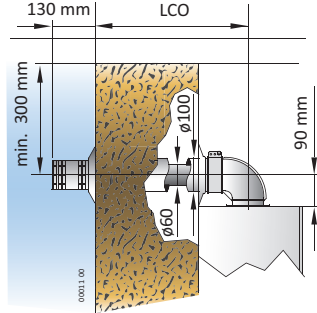

Example of horizontal coaxial system (C<sub>12</sub>)

Model	Coaxial system Ø60/100 mm			
	LCO min÷max (m)	LCV min÷max (m)	Reducer	
			LCO or LCV length (m)	Ø mm
25 F	0.5 ÷ 4	1 ÷ 5	up to 1	41 (F)
			1 to 2	46 (R)
			more than 2	NO
30 F	1 ÷ 3	1 ÷ 4	1	44 (F)
			1 to 2	46 (R)
			more than 2	NO
35 F	1 ÷ 4	1 ÷ 5	1	46 (F)
			more than 1	NO

(F): the reducer is supplied with the boiler  
 (R): the reducer is available on request  
 the diameter is punched on the reducer itself



# Adjustment and Maintenance



**ATTENTION:** the operations described below must be carried out only by qualified personnel [authorized by ITALTHERM].



**When regulation/measuring is over, remember to tighten pressure tapping point screws and ALWAYS check for gas leaks!**



Before boiler ignition, **verify that pump is not blocked** due to its inactivity: **unscrew the plug** located in the middle of the cap **to gain access to the rotor shaft**, and **turn** it manually using a screwdriver or another suitable tool.



During the first ignition of the brand **new boiler**, it is necessary that **burner works for at least 30 minutes, before performing combustion checks**. During this time, the fumes of the eventual residual manufacturing materials are produced, and they could alter the measured values.

*Remark: during the first 10 minutes of electrical power supply, the re-ignition delay is nil.*

## First starting up

All boilers are tested and factory set during manufacture; however it is advisable, during the first starting up, to perform the following checks and, only if necessary, the adjustments that could be necessary.

1. check the inlet gas pressure and flow (see "Inlet gas check" on page 29);
2. check the burner pressure at maximum and minimum power input and gas valve adjustment (see "Max and Min pressure adjustment" on page 30);
3. adjust the max power output in heating mode (see "Max heating power adjustment" on page 31);
4. eventual customization of the electronic settings to adapt the boiler work to particular system requirements (see "Electronic settings" on page 33).

## Access to the inside of the boiler

1. Unscrew the screws **1** and remove the lower grid **2**, if any;

*Remark: Lower grid is spare inside packing, not assembled.*

2. Loosen the screws **11** and push the plates **12** backwards;
3. Push the front panel **3** upwards and remove it, unhooking it from the heads of the screws **4**;
4. unscrew the two screws **7** and overturn downwards the control panel **8**;

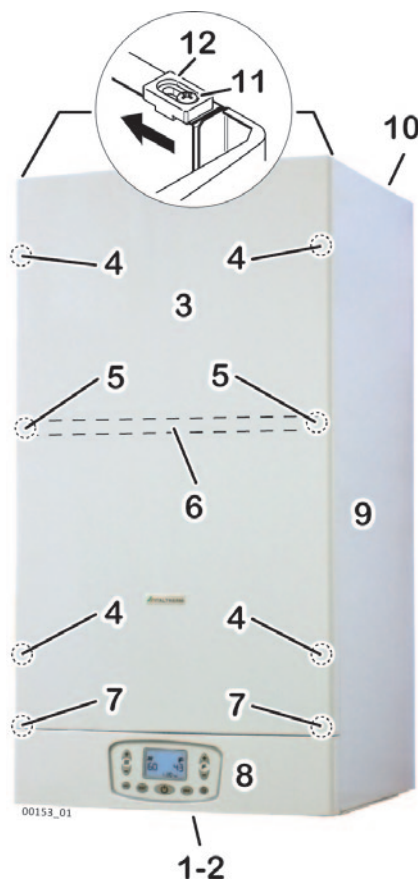

5. Should the removal of the side panel(s) **9** be necessary:
  - unscrew the screws **5** and remove the bracket **6**;
  - remove the panel **9** upwards, slightly displacing it outwards to free it from the chassis, unhooking it from the tongues **10**;
6. after the regulations (described in the following paragraphs), close the boiler repeating everything in the other sense, carefully hooking (if removed) the panel(s) **9** to the tongues **10** and the front panel **3** to the screws **4**, locking it by the screws **11** and the plates **12**.

## Inlet gas check

**Remark:** The pressure should be measured at nominal input, so this test must be performed with the burner ignited.

1. Loosen (2-3 turns) the screw of pressure tapping point for gas inlet **2** of the gas valve and insert the manometer sensor;
2. check that the measured pressure complies with the inlet gas nominal pressure (see "Technical data" on page 42).
3. close the pressure tapping point **2** and check the absence of gas leaks.

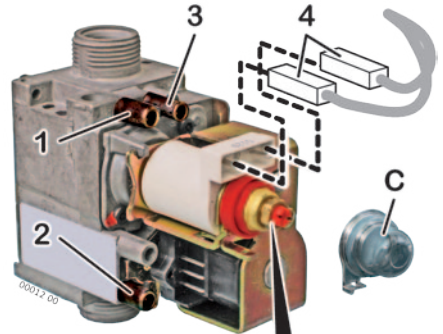

Pressure tapping points:

- 1 outlet
- 2 inlet
- 3 equalization (VENT)

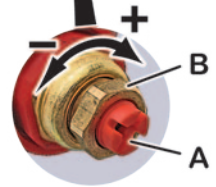

## PCB parameters settings (technician menu)

These settings are reserved to Technician only. The procedure how to get in the boiler parameters is known by technician only thanks to a combination of steps which allows to gain the boiler parameters.

A few of these settings allow to optimise and tailor the boiler working, while a few others allow to set the boiler during maintenance operation.

The digits under the symbol **.III** on the left side of the display indicates the number of the parameter. Instead, the number on the right side (usually under the symbol **F** or by the shown number placed at the bottom side of the display) is referred to the parameter value (setting) the parameter is set on.



In case of PCB replacing, check all of the parameter settings otherwise set them properly.

Please, do not modify any firm setting if this is not required.

## Main boiler parameters (PC)

The parameters listed in the following table are limited to those described in this handbook. The complete parameter list is available in the documentation for the technician.

Parameter	Adjustment range (factory setting)	Description
<b>01</b>	0-1 (*)	Type of GAS supply:  <b>Value 0</b> = for <b>Natural Gas (G20)</b> supply <b>Value 1</b> = for <b>LPG (G30/G31)</b> supply  <i>Note (*)</i> : The factory setting depends on the gas type arranged in factory for the boiler.   To change the type of gas supply, it is necessary to follow the complete instructions described in the paragraph "Gas conversion" on page 34.
<b>04</b>	0...99 (99)	It indicates the CH boiler power according to the maximum nominal boiler power (maximum boiler power is determined by the gas valve regulation).  See details in "Max heating power adjustment" on page 31.
<b>12</b>	0-1 (0)	By setting the parameter on 1, the burner fires up at the maximum boiler power without modulating the flame. This allows a few required operation (like the gas valve regulation or the flues test). For deeper details see paragraph "Max and Min pressure adjustment" on page 30 otherwise "Combustion check" on page 35.  <i>Note</i> : During this function mode, there are no burner temporization time before restarting once the primary system get the limit temperature. It means that at each burner power off, the burner will rapidly fire up again.  By setting the parameter value on 0, the burner powers off

## Max and Min pressure adjustment

- Loosen (2-3 turns) the screw of pressure tapping point for gas outlet **1** of the gas valve and insert the manometer sensor. In the forced draught models unthread from the "Vent" **3** the silicon tube coming from the sealed chamber;
- Activate the boiler to its maximum output not modulated, using the "Chimney-sweeper" function, that activates by entering the technician menu and setting the parameter **12** to value **1** (see also "PCB parameters settings (technician menu)" on page 29);

*Note*: normally the heat produced by the boiler is drained on the heating system. To drain it through the DHW, fully open a DHW tap.

- wait at least **10 seconds** and verify that the measured pressure corresponds to the MAX value indicated in the Burner Pressure table (see page 32), with regard to the boiler model and gas type;
- extract one of the connectors **4** that supply the modulation coil; verify that the measured pressure corresponds to the MIN value indicated in the Burner Pressure table (see page 32), with regard to the boiler model and gas type;
- reinsert the connector **4** ;

6. if it is necessary to adjust the regulation, proceed as it follows, referring to the figure:
  - take off the protection cap C ;
  - adjust MAX pressure acting on the nut B (10 mm). Turn clockwise to increase pressure, counterclockwise to decrease pressure;
  - extract again one of the connectors 4 ;
  - adjust MIN pressure acting on the screw A (with a 4 mm screwdriver), paying attention not to temporarily move the nut B . Turn clockwise to increase pressure, counterclockwise to decrease pressure;
  - reinsert the connector 4 and check that MAX pressure is not changed;

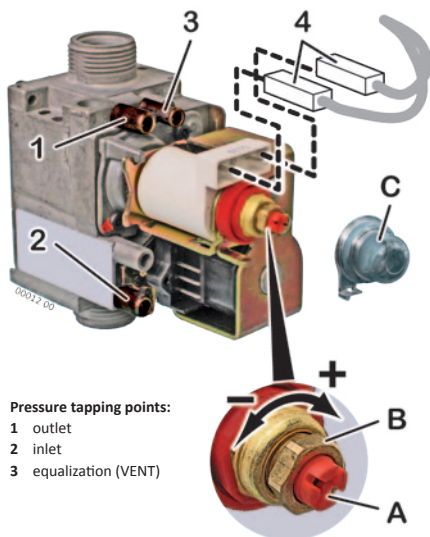

**Important: LOCK THE ADJUSTMENT DEVICE AFTER ANY SETTING OPERATION.**

- mount the cap C ;
7. for the forced draught models reinsert the tube in the "Vent" 3 of the gas valve. **ATTENTION: after this operation, the value measured by the manometer could decrease** due to pressure compensation. This fact is **normal** and does not require any change of the regulation;
  8. screw the pressure tapping point screw for gas outlet 1 and **verify that there is no gas leak.**
  9. To switch the burner off, quit the technician menu (see also "PCB parameters settings (technician menu)" on page 29). The boiler switches to OFF mode.

## Max heating power adjustment

The maximum heating power output must be set in accordance with the system requirements (stated in the project). Once you know the power suitable for the heating system, refer to the "Burner pressure tables" on page 32 and find the burner pressure for the boiler model and for the type of gas used.

1. Loosen (2-3 turns) the screw of pressure tapping point for gas outlet 1 of the gas valve and insert the manometer sensor. In the forced draught models unthread from the "Vent" 3 the silicon tube coming from the sealed chamber
2. ensure that there are NOT domestic hot water requests (no open taps) and that the heat produced by the boiler can be drained by the heating system;
3. enter the technician menu (see "PCB parameters settings (technician menu)" on page 29), select the parameter **04** and get ready to change its value. The burner ignites;
4. set the parameter **04** to the value that corresponds to the required power output (refer to the "Burner pressure tables" on page 32);

**Remark:** the value from 00 to 99 that appears on the display during the setting, is foreseen to be read at the end of the adjustment and to be eventually re-used as a quick reference to set the boiler again to the same heating power.

5. for the forced draught models reinsert the tube in the “Vent” **3** of the gas valve. **ATTENTION: after this operation, the value measured by the manometer could decrease** due to pressure compensation. This fact **is normal** and does not require any change of the regulation;
6. screw the pressure tapping point screw for gas outlet **1** and **verify that there is no gas leak**.
7. To switch the burner off, quit the technician menu (see also "PCB parameters settings (technician menu)" on page 29). The boiler switches to OFF mode.

The MAX power for the heating system is adjusted now.

## Burner pressure tables

	HEAT OUTPUT		par. 04 value	NATURAL GAS G20		BUTANE G30		PROPANE G31	
	kW	kcal/h		mbar	mm H <sub>2</sub> O	mbar	mm H <sub>2</sub> O	mbar	mm H <sub>2</sub> O
<b>Time 25 F</b>	MIN. 9.1	7826	00	2.1	21	4.7	48	4.7	48
	10	8600		2.5	26	5.4	55	5.4	56
	12	10320	↓	3.6	36	7.6	78	8.0	81
	14	12040		4.8	49	10.2	104	11.1	113
	16	13760	↓	6.2	63	13.1	134	14.8	151
	18	15480		7.8	79	16.4	167	19.0	194
	20	17200	↓	9.5	97	20.0	204	24.0	245
	22	18920		11.3	116	23.8	243	29.6	302
	MAX. 23.8	20468	99	13.1	134	27.4	279	35.1	358

	HEAT OUTPUT		par. 04 value	NATURAL GAS G20		BUTANE G30		PROPANE G31	
	kW	kcal/h		mbar	mm H <sub>2</sub> O	mbar	mm H <sub>2</sub> O	mbar	mm H <sub>2</sub> O
<b>Time 30 F</b>	MIN. 11.4	9804	00	1.9	19	4.4	45	4.4	45
	12	10320		2.2	22	5.2	53	5.3	54
	14	12040	↓	3.1	32	6.9	71	7.2	74
	16	13760		4.0	41	8.9	91	9.5	97
	18	15480	↓	5.0	51	11.1	113	12.2	124
	20	17200		6.1	62	13.5	138	15.2	155
	22	18920	↓	7.3	74	16.1	164	18.6	190
	24	20640		8.5	87	18.8	192	22.4	228
	26	22360		9.9	101	21.7	222	26.5	271
MAX. 28.4	24424	99	12.0	122	28.0	286	36.0	367	



	HEAT OUTPUT		par. 04 value	NATURAL GAS G20		BUTANE G30		PROPANE G31	
	kW	kcal/h		mbar	mm H <sub>2</sub> O	mbar	mm H <sub>2</sub> O	mbar	mm H <sub>2</sub> O
Time 35 F	MIN. 11.9	10228	00	1.8	18	4.8	49	4.4	45
	14	12040		2.5	25	6.5	66	6.1	63
	16	13760	↓	3.2	33	8.2	84	8.1	82
	18	15480		4.1	42	10.1	103	10.3	105
	20	17200	↓	5.0	51	12.2	124	12.8	131
	22	18920		6.1	62	14.3	146	15.6	159
	24	20640	↓	7.2	74	16.6	169	18.7	191
	26	22360		8.5	86	18.9	193	22.1	226
	28	24080	↓	9.8	100	21.4	218	25.8	264
	30	25800		11.2	114	23.9	244	29.9	305
MAX. 32.5	27979	99	13.0	133	27.0	275	35.0	357	

## Electronic settings

### Accessing the main board

To access the main board:



**Cut off the electrical supply to the boiler.** Restore the supply after having closed the control panel rear cover.

- ▶ unscrew the screws **1** and remove the back cover of the control panel.

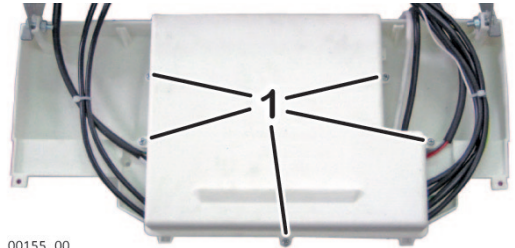

00155\_00

## Main board settings

ON the PCB there are **6 micro-switches SW1÷SW6** and two trimmers **P1 and P2**.



**Disconnect the power supply** before approaching the micro-switches. Restore the power supply only after you have closed the back cover of the control panel.



Changes to micro-switches and trimmers status have no effect until the boiler is electrically supplied (they are red during the board startup, when the supply is connected).

**In all of TIME boilers model range, the settings must be as follows**, otherwise the boiler does not work properly:

- ▶ micro-switches **SW1÷SW5** in **OFF** position and **SW6** in **ON** position. **Look out:** keep in mind that the micro-switches **firm setting is all them in OFF position**, therefore **when replacing the PCB turn/set the micro-switch SW6 in ON**.

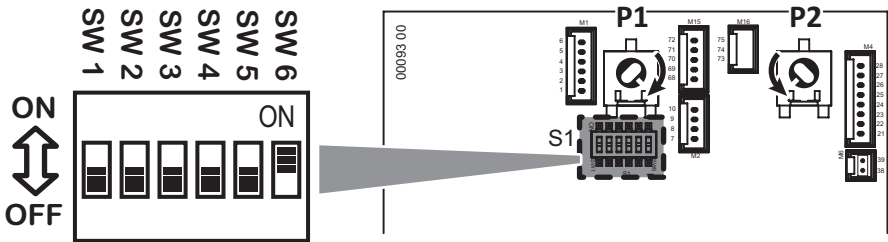

- ▶ the **P1** and **P2** trimmers position is indifferent, anyway it's suggested to leave them set as in the firm: **P1** fully turned clockwise and **P2** fully counterclockwise, as shown in the figure.

## Gas conversion



**ATTENTION:** the operations described below must be carried out only by qualified personnel [authorized by **ITALTHERM S.r.l.**].

For gas conversion, use the nozzles supplied by boiler manufacturer only.



Using **LPG**, it is absolutely necessary to install a suitable pressure reducer upstream the boiler.

1. Enter the technician menu (see "PCB parameters settings (technician menu)" on page 29) and set the parameter **01** on the required gas kind the boiler is required to work with:
  - **0 = Natural gas (G20)**,
  - **1 = LPG (G30/G31)**
2. Disconnect the boiler from the electrical supply. Remove the boiler cover as described in the paragraph "Access to the inside of the boiler" on page 28.
3. Ensure that the inlet gas pressure complies with the required nominal pressure (see "Technical data" on page 42) and that the gas flow is sufficient to guarantee the appliance correct work.
4. On the forced draught models, open the sealed combustion chamber.
5. Remove the pipe between the gas valve and the injectors bar.
6. Remove injectors bar and replace the nozzles\* with the ones suitable for the available gas type, using a 7 mm. spanner (see figure). The nozzles number and diameter is stated in the table "Technical data" on page 42.

7. Reassemble injectors bar and pipe, replacing gaskets. Check, with burner ON, that there are no gas leaks. On the forced draught models, close the sealed combustion chamber;



\* Install the nozzles kit with the supplied washers, although the existing nozzles, factory fitted in the boiler, are originally without washer.

8. Verify, with burner ignited, the inlet gas pressure (see page 29).
9. Check and if necessary adjust the gas valve maximum and minimum pressure (see page 30) and the heating maximum power (see page 31).

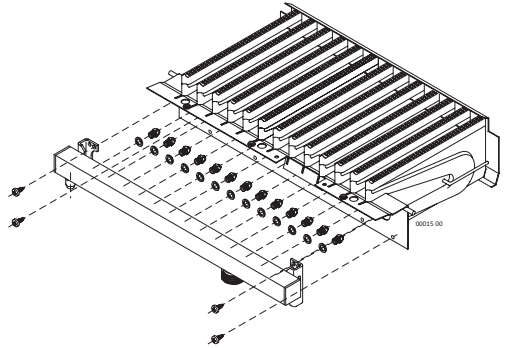

10. **Check that there are no gas leaks.**

11. Apply the sticker indicating the type of gas (supplied with the kit) on the suitable area on "WARNING" label inside the boiler.

## Combustion check

The boiler has the "chimney-sweeper" function, forcing burner ignition at the maximum output not modulated. This function allows more reliable measurements of those obtained when the gas boiler is activated through the room thermostat or hot water demands.

- ▶ Prepare the instruments for combustion checking;
- ▶ activate the boiler to its maximum output not modulated, using the "Chimney-sweeper" function, that activates by entering the technician menu and setting the parameter **12** to value **1** (see also "PCB parameters settings (technician menu)" on page 29);

**Note:** normally the heat produced by the boiler is drained through the CH heating system. To drain it through the DHW, fully open a DHW tap.

- ▶ make the checks and measurements;
- ▶ switch the burner off, by quitting the technician menu (see also "PCB parameters settings (technician menu)" on page 29). The boiler switches to OFF mode.

**Remark:** the burner will switch off automatically when reaching the maximum temperature, and in any case after 15 minutes.

## Hydraulic settings (pump speed)

The pump has a selector which allows to reduce the speed, so as to reduce the noise produced by the too rapid circulation of the liquids in too small heating systems.

- **III = Maximum Speed** (Factory setting)
- **II = Medium Speed**
- **I = Minimum Speed** (use only if strictly necessary; test the heating system, verifying that no overheating problems occur).

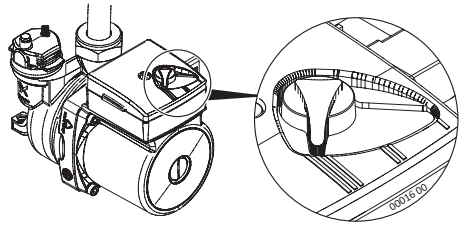

## Draining the heating system

When it is necessary to drain the heating system, proceed as described here below:

- ▶ Unscrew the cap **3**;
- ▶ connect a rubber pipe to the draining tap terminal **2**;
- ▶ put the other end of the pipe in a suitable drain or sink;
- ▶ open the draining tap by turning the nut **1** counter-clockwise, using a suitable spanner;
- ▶ when the pressure is COMPLETELY drained, it's possible to open the radiators venting valves, to allow the air inlet. The complete system drain is possible only draining the liquid from the lowest point of the system itself.
- ▶ when everything is over, close taps (turning the nut **1** clockwise) and air vents;
- ▶ screw the cap **3** on the terminal **2**.

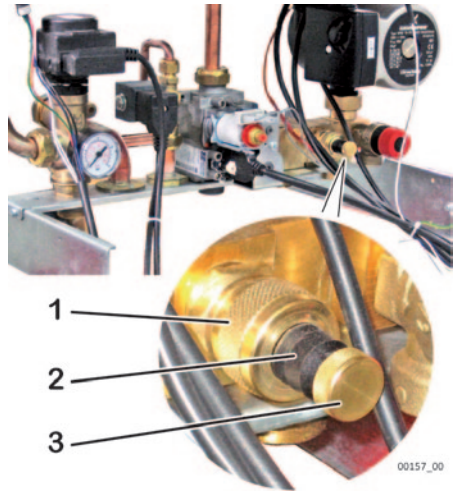

**(i)** In the primary exchanger a certain quantity of water of the heating system remains. If you want to remove the boiler from the wall, we advice you to close with plugs the hydraulic inlet/outlet heating system connections.







## Alarms - boiler block





Following a malfunction, the boiler can lockout and show a particular signal, **RESET** or **SERVICE** on the display, with an alarm code "E...". In the following table, all the alarm signals are listed, their most probable causes and the suggested solutions. Generally:







- **RESET** identifies those **alarms the user can restore** by pressing the **RESET** button. It normally **blinks**, but after 5 reset actions in 24 hours the action on the **RESET** button has no more effect. *To have 5 further reset possibilities, it's possible to switch off the electrical supply to the boiler for 30 seconds, by using the purposed external switch, even if this work-around won't solve the problem and it will be necessary to call the Service Centre;*
- **SERVICE** identifies those **alarms the user can not restore**, as they are generated by the diagnostic system when a component has been detected as faulty. *The user is allowed to switch off the electrical supply to the boiler for 30 seconds, by using the purposed external switch, but should the alarm happen again, it will be necessary to call the Service Centre.*



Operations accompanied by the symbol  are always reserved to the Technician. Operations with grey background are reserved to the Technician.

Signal	Probable causes	Suggested solutions
<b>RESET</b> <b>E01</b>	Boiler just installed (air mixed to gas).	<p>Retry the ignition several times: use the <b>RESET</b> button.</p> <p><i>When the 5 reset possibilities are over, to have 5 more, it's possible to switch off the electrical supply to the boiler for 30 seconds, by using the purposed external switch.</i></p>
	The flame has extinguished or it did not ignite	<p>Restore the boiler function by using the <b>RESET</b> button.</p> <p> In case of frequent blocks, verify the correct combustion, the good state and the cleaning of the burner.</p>
	 Incorrect combustion / flame detachment from the burner	<p>Check that the Inlet/Outlet Ducts and the respective terminals are clean and in good condition, and that there are no leaks in them. During the installation, respect the regulation prescriptions, the slopes and the lengths (see "Flue systems" on page 24).</p> <p><i><b>Note for the TECHNICIAN:</b> The burner flame is not detected by the control electronics because it has not turned on or it has suddenly turned off, or it has detached from the burner, because of an incorrect combustion. This can be due, in example, to combustion product reflow into inlet duct, leaks in inlet/outlet ducts or errors in sizing of ducts (ducts length out of the allowed range, and/or wrong use of the reducer on boiler's outlet).</i></p>
	 Incorrect electrical power supply	<p>Ensure that the Live, Neutral and Earth connections are correct and efficient and in particular that the Live and Neutral are not swapped (see "Electrical diagram" on page 46).</p> <p><i><b>Remark:</b> The problem could also be caused by an incorrect distribution of electricity on the network (neutral unbalanced).</i></p>
<b>RESET</b> <b>E02</b>	the boiler has overheated and the Safety Thermostat has triggered	<p>Restore the boiler function by using the <b>RESET</b> button. If necessary, wait at least 20-30 minutes (to make the boiler cool) and try again. If the lockout persists or reappears, call the Service Centre.</p> <p> Verify the safety thermostat functionality. Detect the causes of the overheating, e.g. an insufficient circulation in the primary circuit; max gas pressure out of the limits or maximum heating power excessive for the heating system size.</p>
	<b>RESET</b> <b>E03</b>	<p>Restore the boiler function by using the <b>RESET</b> button.</p> <p>If the lockout persists or reappears, call the Service Centre.</p> <p> check the efficiency of the flue; of the air inlet / flue outlet ducts; of the flue flow detection device.</p>
<b>SERVICE</b> <b>E05</b> 	Failure to the system flow temperature probe.	<p>Check the cabling of the system flow temperature probe.</p> <p>Replacement of the system flow temperature probe.</p>
<b>SERVICE</b> <b>E06</b> 	Failure to the DHW temperature probe.	<p>Check the cabling of the DHW temperature probe.</p> <p>Replacement of the DHW temperature probe.</p>

Signal	Probable causes	Suggested solutions
<b>SERVICE E09</b>	Periodical Service maintenance	Call Service Technician for planned maintenance operations. <i>Pushing RESET, User can cancel this for 3 times. After that the signal remain on display. Even with this signal present, boiler is still working properly.</i>
<b>RESET E10</b>	Low system pressure and SW6 wrong setting.	 Disconnect the electrical supply to the boiler. On the main board, check that the microswitch SW6 (that enables the automatic system filling) is switched to ON as described in the paragraph "Electronic settings" on page 33. During re-activation, it's possible that an automatic filling cycle is performed (see "E18").
<b>RESET E11</b>	Failure of the flue detection device	Restore the boiler function by using the <b>RESET</b> button. If the lockout persists or reappears, call the Service Centre.   The Flue Pressostat contact is closed (flow detection) even before the fan starts.
<b>RESET E18</b>	Automatic filling in progress	The CH system water pressure was insufficient for the normal functioning so the boiler started the automatic water filling in the CH system. Once the right pressure is achieved, the error code automatically disappears and the boiler restart the normal function.
<b>SERVICE E19</b>	Automatic filling in not completed after 4 minutes.	During the automatic filling in (see "E18") the system pressure does not achieve the right value within the preset time. Maybe due to: <ul style="list-style-type: none"> <li>• inlet water pressure from the net is not sufficient (see "Technical data" on page 42);</li> <li>• inlet water cannot enter the boiler for likely closed tap installed in the inlet way.</li> </ul> Try to restart the boiler by powering the boiler off for 30 second and the power that on again from the bipolar switch.   Filling in valve is blocked/broken/or it is not electrically supplied • Inlet filters are clogged • Big quantity of scale in the water • Big loss of water in the CH system.
<b>SERVICE E21</b>	Low system pressure <i>(after the four filling in attempts)</i>	The boilers has filled in water (see "E18") for three times within the latest 24 hours, but now the system pressure has dropped again. Likely there is a loss of water in the CH system.  Try to restart the boiler by powering the boiler off for 30 second and the power that on again from the bipolar switch. <i>During the power-up, an automatic filling in cycle could start (see "E18").</i>  <i>Note: it is possible to experience this alarm code during the first filling in when the boiler is just installed due to bleeding of air from the system. For this reason, at the first time the boiler get electrically supplied, the number of fillings allowed before showing the error code are 5 and not 3 for the first 24 hours after the installation.</i>  <i>Remark: Consider that the pressure, in normal conditions, should not decrease with the progress of the time. If this happens, there is probably a loss in the heating system. Sometimes the loss is so small that it doesn't leave evident signs, but with the progress of the time it can cause the decreasing of the pressure. Also the opening of the manual venting taps of radiators (intentional or unintentional) makes the pressure decrease. Check that this doesn't happen.</i>   Loss in the heating system.

Signal	Probable causes	Suggested solutions
<b>SERVICE</b> <b>E22</b> 	Memory-stored data not coherent.	<p><b>User:</b> Disconnect the electrical supply to the boiler by operating the suitable external bipolar switch, then connect it again after a few minutes. If the lockout persists or reappears, call the Service Centre.</p> <p>Redo all the boiler settings ("Max heating power adjustment" on page 31 and "Electronic settings" on page 33) to update the data in the main board memory.</p> <p>Replace the main board (consequently, redo the "Max heating power adjustment" on page 31 and "Electronic settings" on page 33).</p>
<b>RESET</b> <b>E24</b> 	Cabling configuration error.	<p><b>User:</b> Try a boiler reset by using the <b>RESET</b> button. If the lockout persists or reappears, call the Service Centre..</p> <p>Refer to the electric diagram (page 46) and check the integrity of the jumper between terminals 57 and 58 of M12 connector.</p> <p>If, in place of the jumper, the safety thermostat of the low temperature CH was connected, check the cause of its triggering..</p>
<b>SERVICE</b> <b>E31</b> 	Communication error between the Remote Control (if present) and the boiler	<p><b>User:</b> select the <b>Summer</b> mode using the button .</p> <p>Problems on the optional Remote Control connection link (passing close to supply cables or other electromagnetic field sources; connection failure; cable length over 50 meters).</p>
<b>SERVICE</b> <b>E33</b> <b>E34</b> 	Cabling configuration error.	<p><b>User:</b> Try a boiler reset by using the <b>RESET</b> button. If the lockout persists or reappears, call the Service Centre.</p> <p>Refer to the electric diagram (page 46) and check the integrity of the wirings, especially the eventual short cable jumpers between two contacts of the same connector (on the cabling connections to the electronic board).</p>
<b>RESET</b> <b>E35</b>	Unexpected flame the control electronic has detected the flame on the burner when this one should be off	<p>Wait for the boiler automatic reset (5 minutes) or reset it manually by using the <b>RESET</b> button. If the lockout persists or reappears, call the Service Centre</p> <p> Detect eventual malfunctioning of the gas valve (that does not stop fully the gas flow, so the burner remains ignited) or of the electronics, flame detection section (that detects the flame presence even if it's absent).</p>
<b>SERVICE</b> <b>E38</b> 	Failure to the outdoor temperature probe (optional).  The outdoor temperature probe, that was recognized and working, now results faulty.	<p><b>User:</b> Call the Service Centre.</p> <p><i>The boiler now works either in heating and in hot water, like as the external boiler had never been installed, so the heating system temperature is set directly and not as a function of the outdoor temperature. The alarm is displayed to inform that the accessory is no more efficient (consider that, on a first analysis, the boiler seems to work perfectly). Important: if the boiler is turned off and then on again, it's possible** that the alarm is no more displayed, even though the problem persists.</i></p> <p>Check the cabling of the outdoor temperature probe.</p> <p>Replacement of the outdoor temperature probe.</p> <p><i>** The alarm shows again only if the resistance of the probe is out of tolerance or in short-circuit. On the contrary, if the probe or the relevant cabling is interrupted, when the electrical supply is restored the boiler will consider the external probe absent and, in Winter mode, it will work in normal mode (temperature shifting disabled).</i></p>

Signal	Probable causes	Suggested solutions
<b>SERVICE</b> <b>E39</b>	Suspected freezing After a power failure, the boiler detected temperatures at the Heating and DHW probes equal to, or less than, 0°C when power was restored	The display shows the alarm code 39 while the boiler inhibits the ignition of the burner and activates the circulator, forcing water to circulate in the hydraulic circuits.  If, during this time, the temperatures measured by the probes rise above +1°C, the alarm is reset and the boiler returns to the normal operation.  Otherwise, the alarm will persist and you should suspect that water has frozen at one or more points of the hydraulic circuit of the boiler and/or system (with possible damage to the frozen parts). If the alarm persists, call a qualified technician.
		 Find/replace the parts damaged by the freezing.
<b>SERVICE</b> <b>E42</b>	System error Anomaly of inner boiler device(s)  Mains electrical power supply out of tolerance limits	Detect the fault or anomaly also referring to the technical literature reserved to the service centres.
<b>SERVICE</b> <b>E46</b>	Cabling configuration error.	<b>User:</b> Try a boiler reset by using the <b>RESET</b> button. If the lockout persists or reappears, call the Service Centre.  Refer to the electric diagram (page 46) and check the integrity of the wirings, especially the eventual short cable jumpers between two contacts of the same connector (on the cabling connections to the electronic board).
<b>SERVICE</b> <b>E50</b>	Electric supply out of tolerance for 3 times in last 5 minutes.	Verify, with qualified person, that Electric Supply and its tolerances are respecting "Technical data" on page 42.
<b>SERVICE</b> <b>E62</b>	Communication error between the Display Board and the Main PCB.	Refer to the electric diagram (page 46) and check the integrity of the wirings between the Display Board and the Main PCB.  Replace the Display Board and the Main PCB.
<b>SERVICE</b> <b>E91</b>	System pressure transducer failure.	Check the cabling of the system pressure transducer.  Replacement of the system pressure transducer.
<b>SERVICE</b> <b>E92</b>	Excessive system pressure.	<b>User:</b> Try reducing the system pressure (e.g. draining some water from the purging valve of a radiator or similar) and eventually press the <b>RESET</b> button. It could be useful to set the display of the system pressure, that normally should be about 1 Bar (ved. "Set the display with 4 digits" on page 11).  If the lockout persists or reappears, call the Service Centre.  Check the efficiency of the expansion vessel.  Check the correct shutting of the filling electrovalve, the efficiency of the relevant filter and the presence of solid particles in the electrovalve body.



Signal	Probable causes	Suggested solutions
<b>SERVICE E93</b>	Filling in not completed - reached the water amount limit.	<p>The boiler detected an excessive amount of water entered in the heating system during the filling cycle(s).</p> <p>If you don't detect traces of leaks (that might be the cause of the effective alarm), try to restart the boiler by powering the boiler off for 30 second and the power that on again from the bipolar switch.</p> <p>If the lockout persists or reappears, call the Service Centre.</p> <p> Leak in the system • Specific technical parameter (disabled by factory default) set on a too low value.</p>
<b>E98</b>	System clock data loss	<p>The clock/calendar of the boiler is out of date, likely because of a long power supply failure.</p> <p>Adjust the clock again (see "Hour and day setting" on page 11) and check/restore the eventual DHW program (see "Setting the Acqua Step program no. 3 - User" on page 12).</p>

## Warnings for servicing



All servicing operations and gas conversions **MUST BE CARRIED OUT BY QUALIFIED TECHNICIANS**, in compliance with the norms and laws in force (see an indicative list on page 4). Moreover, **MAINTENANCE** operations must be carried out in compliance with the manufacturer prescriptions and with the laws and rules presently in force, for the parts not mentioned in this handbook; we advice to perform them at least once a year to maintain the boiler's performance.

**A careful servicing is always a guarantee of safety and energy saving.** Normally, it will be necessary to execute the following operations:

- ▶ Remove any possible oxidization from burners and electrodes;
- ▶ Remove the scale from the exchangers;
- ▶ Check integrity and stability of the ceramic fibre coverings in the combustion chamber and proceed eventually to substitution;
- ▶ Check the boiler ignition, switching off and operation;
- ▶ Check the water and gas connections tightness;
- ▶ Check the gas consumption at the minimum and maximum output;
- ▶ Verify that safety devices are correctly working;
- ▶ Verify the correct functioning of control and adjusting devices;
- ▶ Verify periodically the absence of leaks of combustion products to the inner room, the correct functioning and the integrity of the flue outlet ducts and/or devices and of the relevant terminals and accessories;
- ▶ In case of works or servicing of the structures placed near the above mentioned ducts and /or devices and their accessories, switch off the boiler;
- ▶ Do not leave any inflammable tanks and/or substances in the installation room;
- ▶ If the boiler draws directly from the installation room (*type B appliance installed indoor*): Do not clean the room where boiler is installed, while it is working
- ▶ Clean casing with soapy water only. Do not clean casing, other painted or plastic surfaces with thinner.

► In any case of parts replacement, it is mandatory to use ITALTHERM original spare parts.

**ITALTHERM declines any responsibility in case of non-original spare parts utilization.**

**"Once all check and servicing operations have been carried out, the technician must write a report for the user, who must countersign a copy for receipt and vision" as prescribed by the regulation in force.**

## Technical data

TECHNICAL DATA	Gas type	U.M.	Time 25 F		Time 30 F		Time 35 F	
			G20	G30 / G31	G20	G30 / G31	G20	G30 / G31

CE certification			0694 CM 3400					
Class		II <sub>2H3+</sub>	II <sub>2H3+</sub>					
Type			B22 - C12 - C32 - C42 - C52 - C62 - C82 - C92					
Working temperature range (min÷max)		°C	0 ÷ +60		0 ÷ +60		0 ÷ +60	

Max heat input	kW	25.7	25.7	25.7	30.5	30.5	30.5	34.5	34.5
Min heat input	kW	10.3	10.3	10.3	13.0	13.0	13.0	13.5	13.5
Max heat output	kW	23.8	23.8	23.8	28.4	28.4	28.4	32.5	32.5
Min heat output	kW	9.1	9.1	9.1	11.4	11.4	11.4	11.9	11.9
NO <sub>x</sub> Class		2	2	2/2	3	3	2	3	2
CO at 0% O <sub>2</sub> (Qn)	ppm	56.9	72.9 / 38.6	57.6	107.7 / 62.3	66.4	51.8 / 30.9	66.4	51.8 / 30.9
CO <sub>2</sub> at nominal input	%	7.2	7.3 / 7.1	6.5	7.8 / 7.7	6.7	7.3 / 7.1	6.7	7.3 / 7.1
Flue temperature (Qn)	°C	129	126 / 126	113	113 / 113	107	103 / 103	107	103 / 103
Flue mass flow rate (Qn)	kg/h	51.9	58.1 / 59.4	68.8	65.6 / 66.1	74.6	79.3 / 81.1	74.6	79.3 / 81.1

## EFFICIENCY

Nominal efficiency	%	92.8	93.1	94.3
Efficiency at 30% load	%	91.7	90.6	91.3

(follows)

TECHNICAL DATA (cont'd)	Gas type	U.M.	Time 25 F		Time 30 F		Time 35 F	
			G20	G30 / G31	G20	G30 / G31	G20	G30 / G31

### HEATING

Temperature selection range (min÷max)		°C	35÷78		35÷78		35÷78	
Expansion vessel		l	10		10		10	
Expansion vessel pre-loading pressure		bar	1		1		1	
System pressure for automatic filling turning ON/OFF		bar	ON at 0.5 / OFF at 1.2 (±0.2) ON at 0.5 / OFF at 1.2 (±0.2) ON at 0.5 / OFF at 1.2 (±0.2)					
			<i>To allow the correct system filling, the pressure of the domestic water should be higher than the OFF value.</i>					
Max working pressure		bar	3		3		3	
Max system temperature		°C	85		85		85	

### HOT WATER

Flow rate at 25°C temp. rise		l/min	13.7		16.3		18.7	
Flow rate at 30°C temp. rise		l/min	11.4		13.6		15.5	
Min water flow <i>(for the DHW function activation)</i>		l/min	2.2		2.2		2.2	
Min supply pressure <i>(for the DHW function activation)</i>		bar	0.5		0.5		0.5	
Max supply pressure		bar	6		6		6	
Temperature selection range (min÷max)		°C	30÷55		30÷55		30÷55	

### ELECTRICAL DATA

Voltage / frequency (nominal voltage)		V / Hz	220÷240 / 50 (230V -15% ... +10%)					
Power consumption		W	132		142		155	
Level of protection			IP X5D					

(follows)

TECHNICAL DATA (cont'd)	Gas type	U.M.	Time 25 F		Time 30 F		Time 35 F	
			G20	G30 / G31	G20	G30 / G31	G20	G30 / G31

#### DIMENSIONS

Width - Height - Depth	mm	see "Dimensions and connections" on page 18
Weight	kg	38.5      40.0      42.0

#### CONNECTIONS

Hydraulic and gas connections	see "Dimensions and connections" on page 18
Flue: types, lengths and diameters	see "Flue systems" on page 24

#### GAS SUPPLY PRESSURE

Nominal pressure	mbar	20	29 / 37	20	29 / 37	20	29 / 37
Inlet pressure (min÷max)	mbar	17 ÷ 25	28÷30 (G30) 35÷40 (G31)	17 ÷ 25	28÷30 (G30) 35÷40 (G31)	17 ÷ 25	28÷30 (G30) 35÷40 (G31)
Injectors number		13	13	14	14	15	15
Injectors diameter	mm/100	120	75 / 75	130	78 / 78	130	77 / 77

#### GAS CONSUMPTION

Qmax	m <sup>3</sup> /h	2.72		3.22		3.65	
	kg/h		2.02 / 1.99		2.40 / 2.36		2.72 / 2.67
Qmin	m <sup>3</sup> /h	1.09		1.37		1.43	
	kg/h		0.81 / 0.80		1.02 / 1.01		1.06 / 1.05

**Note:** data have been measured with minimum length coaxial flue (see "Flue systems" on page 24).

# Boiler internal components

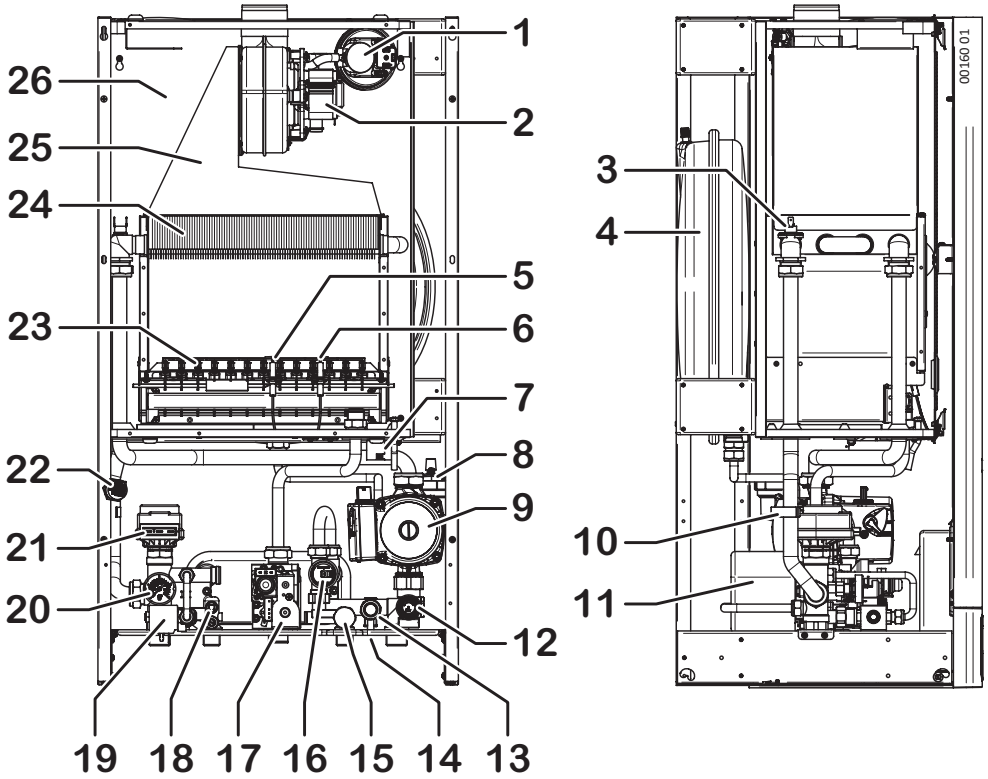

- |    |   |    |                                |
|----|---|----|--------------------------------|
| 1  | Flue pressure switch                                | 16 | DHW flow meter                 |
| 2  | Fan   | 17 | Gas valve                      |
| 3  | Safety thermostat (system flow)                     | 18 | DHW temperature sensor         |
| 4  | Expansion vessel                                    | 19 | System filling in electrovalve |
| 5  | Flame sense electrode                               | 20 | Gauge                          |
| 6  | Ignition electrode (*)                              | 21 | Motorized 3-way valve          |
| 7  | Electronic igniter                                  | 22 | System pressure transducer     |
| 8  | Automatic venting device (incorporated in the pump) | 23 | Burner                         |
| 9  | Pump  | 24 | Primary exchanger              |
| 10 | CH flow temperature sensor                          | 25 | Flue hood                      |
| 11 | DHW exchanger (thermally insulated)                 | 26 | Sealed chamber                 |
| 12 | Safety valve 3 bar                                  |    |                                |
| 13 | Drain valve   |    |                                |
| 14 | By-pass   |    |                                |
| 15 | Filter on inlet water (with inspection cap)         |    |                                |

(\*) Depending on the model, the position and the shape of the indicated items could slightly differ from the drawing.

# Electrical diagram

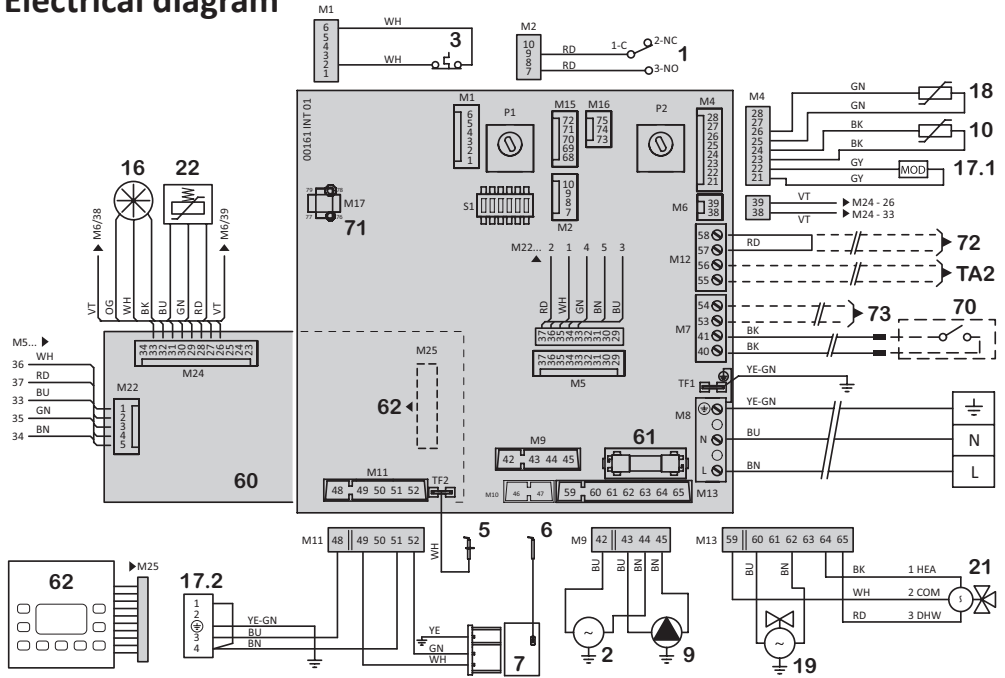

- 1 Flue pressure switch (\*)
- 2 Fan
- 3 Safety thermostat (system flow) (\*)
- 5 Flame sense electrode
- 6 Ignition electrode (\*)
- 7 Electronic igniter
- 9 Pump
- 10 CH flow temperature sensor
- 16 DHW flow meter
- 17.1 Gas valve - modulation control
- 17.2 Gas valve - opening control
- 18 DHW temperature sensor
- 19 System filling in electrovalve
- 21 Motorized 3-way valve
- 22 System pressure transducer
- 60 Display board
- 61 Fuse F2A (2A fast)
- 62 Control keyboard

(\*) i the contacts of these components are shown in rest/cold conditions.

## Optional external devices:

- 70 Room thermostat:** Voltage-free Contact for Room Thermostat or Chronothermostat (for trade) working at safety extra low voltage SELV. Closed contact = heating request.
- Remote control:** Terminals of the original remote control device.  
See also page 49.  
To install, open the junction on the wires and connect them to the device terminals (eventually, extend the cable)
- 71 Connector for CH multi zones PCB kit** with remote control installed
- 72 To optional floor heating system safety thermostat**
- 73 To optional outdoor temperature sensor**
- TA2 To optional room thermostat for zones with different temperature range**

## Abbreviations:

WH	White	COM	Common
BK	Black	DHW	DHW mode
BN	Brown	NC	Normally Closed
BU	Blue	NO	Normally Open
GN	Green	HEA	Heating mode
OG	Orange		
RD	Red		
VT	Violet		

# Hydraulic diagram

This diagram is for information only. To make boiler hydraulic connection either see "Dimensions and connections" on page 18 and eventually "Positioning and fastening" on page 20.

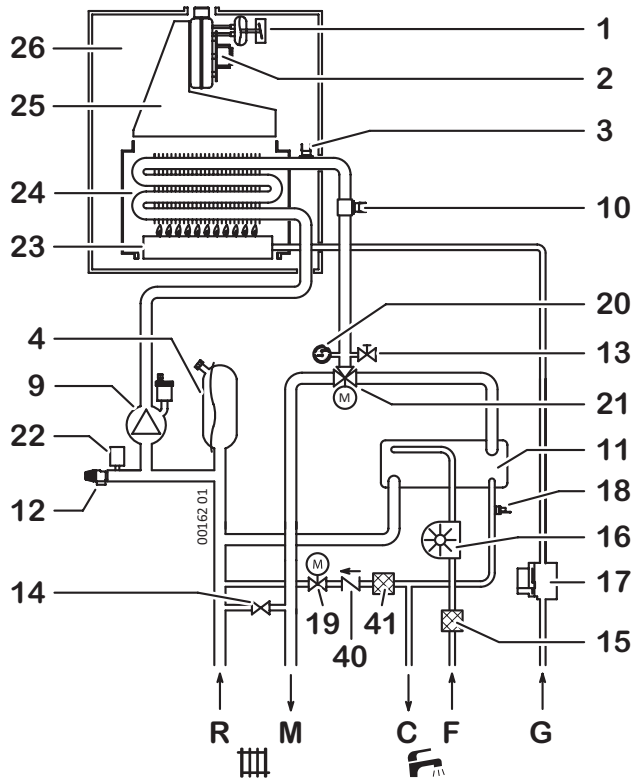

- |    |   |    |  |
|----|---|----|--|
| 1  | Flue pressure switch                        | 20 | Gauge                                    |
| 2  | Fan   | 21 | Motorized 3-way valve                    |
| 3  | Safety thermostat (system flow)             | 22 | System pressure transducer               |
| 4  | Expansion vessel                            | 23 | Burner                                   |
| 9  | Pump (including automatic venting device)   | 24 | Primary exchanger                        |
| 10 | CH flow temperature sensor                  | 25 | Flue hood                                |
| 11 | DHW exchanger (thermally insulated)         | 26 | Sealed chamber                           |
| 12 | Safety valve 3 bar                          | 40 | Check valve                              |
| 13 | Drain valve                                 | 41 | Water filter for filling in electrovalve |
| 14 | By-pass                                     | R  | Heating return                           |
| 15 | Filter on inlet water (with inspection cap) | M  | Heating flow                             |
| 16 | DHW flow meter                              | C  | Hot water outlet                         |
| 17 | Gas valve                                   | F  | Cold water inlet                         |
| 18 | DHW temperature sensor                      | G  | Gas inlet                                |
| 19 | System filling in electrovalve              |    |  |

## Outdoor Sensor Kit

### Installation and setting

The Outdoor Sensor manages automatically the CH flow temperature\*\* as a function of the outdoor temperature, thus avoiding the user to adjust it manually. This function is also named "shifting temperature".

\*\* that's the temperature of the heating elements. Don't mistake it with the room temperature (managed by the room thermostat or by the Remote Control, but not by the boiler) that doesn't depend on the first one.

**The installation must be made by a professionally skilled technician** following the instructions supplied with the kit. Refer to "Electrical diagram" on page 46 for the links to the Main Board.

After the installation of the Sensor, the buttons **+ . . . . .** and **- . . . . .** described in the User section, won't adjust directly the CH flow temperature, but the dispersion factor "kd" that's the response of the outdoor temperature, detected by the sensor, on the CH flow temperature, as shown in the following graph.

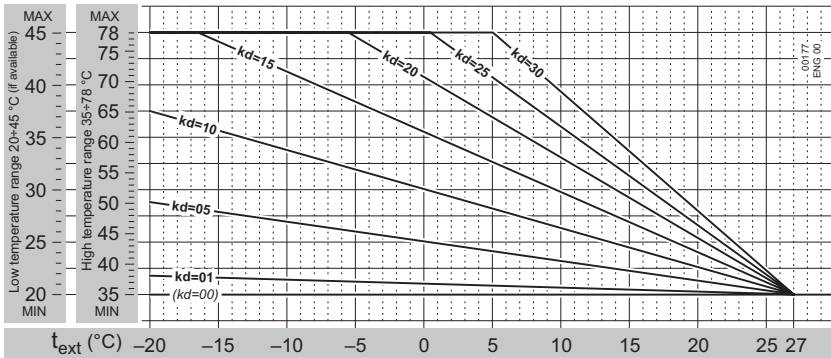

Practically, **kd** value should be adjusted depending on the estimated efficiency of the building's thermal insulation. Its range is from 01 to 30: use **higher values** when there is a **high thermal dispersion** and therefore a **less efficient insulation** (and vice versa).

**(i)** Because of the wide buildings typologies, it's impossible to give precise indications on kd value to set. **The correct setting must be determined case by case and will have, as a result, an optimal comfort in all the climatic conditions** requiring heating, i.e. a prompt reaching of the room temperature with cold weather and no room overheating during mild periods.

### Outdoor Sensor kit and Remote Control

If also the Remote Control Kit is installed, its parameter **P04** (modulation mode) should be set on value **2** (modulating on outdoor sensor and on-off on room sensor) or **3** (modulating on both outdoor and room sensors) as described in the **paragraph 5** of the instruction booklet included in the Remote Control Kit. Afterwards, also the **kd** should be set on this latter (refer to **paragraph 8.6** of the same booklet). On the Remote Control, just because of different display, the **kd** adjustment range is **0.1...3.0** instead of 01...30.



# Remote Control Kit

This remote control is **more than a simple room thermostat**. Thanks to this, it is possible to **manage the boiler in all its settings** like DHW and CH temperature adjustment, **boiler reset** in case of boiler block, and of course it works as a **room thermostat** both in **manual** and **weekly program** mode. It's powered by the boiler (in safety low voltage), so **it doesn't need batteries**.



**(i)** Extract the Remote Control from its package. **Keep the relevant user instruction booklet and annex it to this Manual.**



**Nor the Remote Control neither the relevant cable coming from the boiler must not, for any reason, be connected to the 230Vac supply mains.**



**(i)** To avoid malfunctions due to electrical noise, the Remote Control connections, as well as all low-voltage connections, should be kept separated from power supply cables, e.g. by enclosing it into separate raceways.

The maximum overall cable length shouldn't exceed 50 m.

**(i)** Install the Remote Control at approx. 1.5 m over floor in a place suitable for correct sensing of the room temperature. Do not install behind doors, curtains, near heat sources nor expose to direct sunlight or water sprinkles.

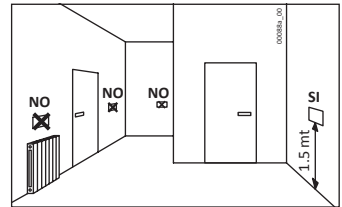

1. Cut off electricity from boiler;
2. install the device as described in the **paragraph 4** of the supplied instruction booklet;
3. link the Remote Control wirings to the "Room Thermostat - Remote Control" cable coming out of the boiler, by means of a suitable bipolar terminal. See also "Electrical diagram" on page 46;

**Note:** *The Remote Control link is not polarized.*

**(i)** Check the correct work of the device. The electronics recognizes it automatically (otherwise the alarm **E31** appears (see "Alarms - boiler block" on page 36) **provided that:**

- on the boiler's control panel, by means of the button , the **Summer** mode is forever set. Hereafter the boiler working modes (even OFF) should be selected on the Remote Control only;
- the main boiler board is set as described in "Main board settings" on page 34.







[www.italtherm.it](http://www.italtherm.it)

**ITALTHERM Srl**

Via S. D'Acquisto, snc • 29010 Pontenure (PC) - IT  
Tel. +39.0523.575611 • Fax +39.0523.575600

[www.italtherm.it](http://www.italtherm.it) • e-mail: [info@italtherm.it](mailto:info@italtherm.it)

960000030\_02\_ENG - 10/03/2015

ITALTHERM Srl declines any responsibility for eventual printing and/or transcription errors in the present manual. In order to constantly improve its products, the company has the right to change features and data written in the present manual, at any time and without notice.



UNI EN ISO 9001:2008