

CITY PLUS

Instruction Handbook for:

- ▶ use
- ▶ installation
- ▶ adjustment
- ▶ maintenance

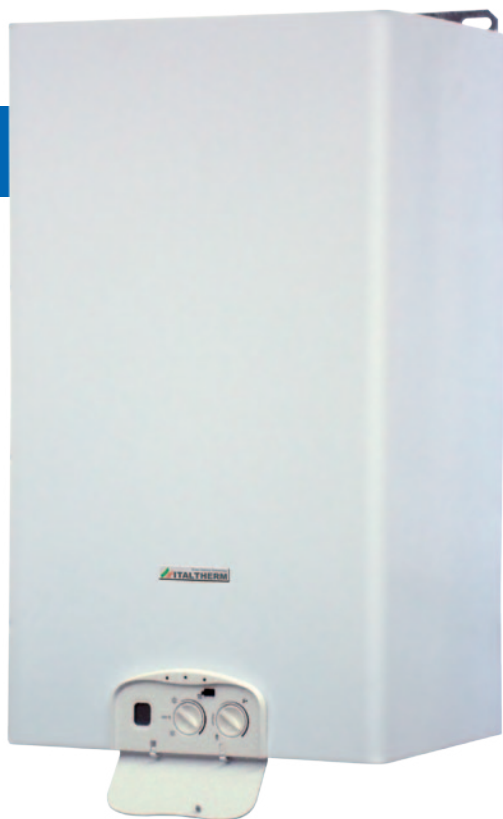

IMPORTANT! Install the gasket included in the documents bag, on the inlet/outlet flange, as shown on page 22.

Table of Content

Safety warnings

Safety warnings symbols legend	4
References to Laws and Norms	4
Personnel in charge of installation	4
Installation, use and maintenance	4
User warnings	5
Important	5
First starting up and Use	5
Installation, first starting up, maintenance and servicing	6
Appliance booklet or central plant booklet	6
Combustion checking	6
Boiler operation and servicing	6

User guide

The front control panel	7
Commands on the lower side	8
Commands outside the boiler	8
Commands related to Domestic Hot Water	9
Typical use	9
Preliminary operations	9
Boiler activation	10
Temperature adjustment	10
Anti-Legionella function	10
Incidental malfunctioning	11
The burner doesn't turn on	11
Shortage of domestic hot water production	11
Boiler inactivity	11
Safety shut off	11
Stand-by mode with anti-frost & anti-locking function	12
"Ambient Anti-Frost" Function	13

Installation

Law and regulation prescriptions for the installer	13
Dimensions and connections	14
Pump capacity diagrams	14
Warnings for the installation of optional kits or special systems	15
Floor heating system	15
Specifications for inlet air	15
Domestic water supply characteristics	15
Protection against freezing	15
Siphon overflow drain	16
Outdoor installation in a partially protected place	16
Positioning and fastening	16

Hydraulic system (DHW and heating)	18
Advices and suggestions to avoid vibrations and noises in the system	18
Cleaning and preservation of the systems	18
Heating system	18
Piping between the boiler and the storage unit	18
Condense drain	19
Heating system filling and pressuring	19
DHW storage tank filling	19
Gas connection	20
Electrical connections of the boiler	21
Electrical connection between the boiler and the storage unit	22
Flue systems	22
Installation of the flue inlet/outlet flange gasket	22
General indications	22
Dimensioning the inlet and outlet ducts	24
Flue system types	25
Examples of installation of inlet and outlet ducts	26

Adjustment and Maintenance

First starting up	27
Maintenance operations	28
Access to the inside of the boiler	29
Venting the primary exchanger	30
Combustion group cleaning	30
Combustion test and adjustment	32
Max heating power adjustment	34
Power input / display / fan rpm table	35
Electronic settings	35
Accessing the main board	35
Main board settings	35
Gas conversion	36
Hydraulic settings (pump speed)	38
Draining the heating system	38
Alarms - boiler block	39
Warnings for servicing	44
Technical data	45
Boiler internal components	47
Electrical diagram	48
Hydraulic diagram	50

Addendum

Outdoor Sensor Kit	51
Installation and setting	51
Outdoor Sensor kit and Remote Control	51
Remote Control Kit	52



Safety warnings





This instructions manual is an essential and complementary part of the product and it is supplied together with the boiler.



Carefully read the manual, achieving all important information for a safe installation, use and servicing.

- ▶ **Carefully keep the manual**, together with the documentation of all the accessories of the boiler and of the system, for any further consultation you may need.
- ▶ **The installation** must be carried out by a qualified technician, in accordance with manufacturer instructions and with the relevant requirements of the current issue.
- ▶ **Carbon monoxide (CO) danger:** the CO is a no-smelling and no-colour gas. When a forced draught boiler with air inlet from the room (appliance type B₂) is installed, permanent ventilation of the installation room is mandatory and extremely important. Ventilation must be made and sized in compliance with Laws and Rules in force. Whatever manumission, closing or neutralization of the permanent ventilation could lead to very serious consequences to people in the rooms, as intoxication by CO, permanent damage and death. Besides, the CO and O₂ mix can be explosive.
- ▶ A **qualified technician** is a person with a specific technical competence in the field of the heating appliances for domestic use and domestic hot water production, in compliance with Laws and Rules in force.
- ▶ The **operations that the user can do** are only and exclusively the ones contained in the "USER GUIDE" section.
- ▶ The manufacturer has no contractual and extra-contractual responsibility for any damage arising from wrong installation, wrong use and non-observance of current laws and instructions given by the manufacturer himself.
- ▶ **Important:** this gas boiler is used to heat the water at a temperature lower than the boiling one, at atmospheric pressure; it must be connected to an heating system and/or to a domestic hot water system, in accordance with its features and power.
- ▶ Packing items (cartons, nails, plastic bags and so on) **must not be left within children easy reach**, as they are potentially dangerous.
- ▶ **Before any cleaning or servicing operation**, disconnect the boiler from the mains electrical supply by means of the main electrical switch and stop the gas supply by means of the suitable cock.
- ▶ **In case of fault** and/or bad operation of the appliance, disconnect it immediately and do not try to repair it by yourselves.
- ▶ **Boiler servicing and repair** must be carried out exclusively by qualified technicians, which will use original spare parts. Strictly observe the above requirement, avoiding any risk of compromising the appliance safety.
- ▶ **If the appliance should be definitively dismissed**, remove or cut off any potential dangerous item.
- ▶ **When transferring the appliance** (e.g. leaving it installed after a removal or a sale of the building), make always sure that the instructions manual is close to the boiler for the future use of new owners and/or installers.
- ▶ This appliance **must be used for its clearly recommended utilization only**. Any other utilization must be considered dangerous and incorrect.
- ▶ It is strictly forbidden to use the appliance **for different purposes** than the specified ones.
- ▶ This appliance must be **installed exclusively to wall**.

Safety warnings symbols legend

 Generic safety warning	 Electrical danger (fulguration)	 Physical danger (personal damage)
 Thermal danger (burns)	 General warning or advice to avoid material damage or to achieve improvements	

References to Laws and Norms

 All the **references to norms and national laws** mentioned in this handbook are indicative as laws and norms are subject to issues and integrations by the authorities in charge. **Also comply to eventual local norms and laws** (not mentioned in this handbook) in force in the territory where the installation takes place.

Personnel in charge of installation

Place here all necessary advices according to national rules about **WORK SAFETY** of Personnel in charge of installation. An example follows:

Law number 192 of 19-August-2005 and further revisions “Title of the law or brief description”.



Always proceed with caution when handling the boiler and carrying out installation/maintenance work as metal parts may cause injuries such as cuts and abrasions. **Wear personal protection devices** (especially gloves) while doing the above mentioned operations

Installation, use and maintenance

Place here all necessary advices according to national rules about **BOILER INSTALLATION**, An example follows.

Law number 412 of 26-July-1993 n°412 and further revisions “Title of the law or brief description”.

User warnings

Important



In case of gas smell:

- 1 - **do not press electrical switches, use the telephone or other objects that can provoke sparks;**
- 2 - **open immediately the windows and the doors in order to cleanse the room air;**
- 3 - **close the gas supply taps;**
- 4 - **call a qualified technician.**



Do not obstruct the ventilation openings of the gas boiler room, in order to avoid possible dangerous situations as the creation of poisonous or explosive mixtures.

First starting up and Use



The first starting up and the maintenance of the boiler must be performed by a professionally qualified staff (for example the installer or the Service Centres authorized by ITALTHERM)

The latter will check that:

- ▶ the label technical data of the gas boiler correspond to those of the gas available;
- ▶ the main burner regulation is compatible with the gas boiler output;
- ▶ the chimney works correctly, expelling the combustion products;
- ▶ the air supply and the combustion products evacuation work correctly, in accordance with the requirements in force;
- ▶ the conditions for a correct ventilation are guaranteed, also when the gas boiler is located inside a closed space (with suitable characteristics).



This boiler is designed and prepared to be supplied with **Natural Gas G20** (Methane) or **Commercial Propane G31**. A qualified technician can convert it to operate with one of these two types of gas above said. It must never be used with **butane gas G30** (that can be present, pure or mixed with Propane G31, in the portable gas bottles for cookers).



The User must not touch sealed items nor break the seals. Only specialized technicians and the official technical service can break the seals of sealed items.



The boiler is fitted with safety devices that block operation the case of problems with the boiler or related systems. These devices must never be disabled: if a device intervenes frequently, have a qualified technician located the cause, even in systems to which the boiler is connected, and in the flue inlet/outlet system that must be efficient and made according to the laws in force (see examples in paragraph "Flue systems" on page 22). If a boiler component has failed, you must only use original replacement parts



When the boiler is off for a long period see the Paragraph "Boiler inactivity" on page 11 for the necessary precautions about the electrical supply, the gas supply and the protection against freezing.



Do not touch the heated surfaces of the boiler, as the doors, the flue, the chimney pipe, etc., also after the boiler operation because, for a certain time, these surfaces are overheated. **Any contact with them can cause dangerous scalds.** It is then forbidden to let children or inexperienced people be close to the boiler, during its operation.

- ▶ Do not expose the wall hung gas boiler to water or other liquids sprinklings, or to vapours directly coming from gas cookers/hobs.
- ▶ Do not obstruct the air inlet or flue outlet terminals, even momentarily or partially.
- ▶ Do not put any object on the gas boiler and don't leave any flammable liquid or solid materials, (e.g. paper, clothes, plastic, polystyrene) in its proximity.
- ▶ This appliance is not intended for use by persons (including children) with reduced physical, sensory or mental capabilities, or lack of experience and knowledge, unless they have been given supervision or instruction concerning use of the appliance by a person responsible for their safety. Children should be supervised to ensure that they do not play with the appliance. *(CEI EN 60335-1:2008-07 § 7.12)*
- ▶ If the gas boiler is going to be definitively unused, call a qualified technician to carry out all required operations, checking in particular disconnection of gas, water and electrical supplies.
- ▶ **Only for those models that draw directly from the installation room** (type B appliances installed in-door): the installation of aspirators, fireplaces or similar appliances in the room where the type B appliance is installed (and in adjacent rooms in case of indirect ventilation) is prohibited except in cases foreseen by rules in force and anyway the installation must be made in compliance with all specific safety measures mentioned in the rules and laws in force, even in case of modifications or additions.

Installation, first starting up, maintenance and servicing

All operations for installation, first starting up, maintenance, servicing and gas conversion **must be carried out by qualified technicians**, in accordance with the Norms and Laws in force.

Maintenance operations must be carried out in compliance with the manufacturer prescriptions, and in compliance with the laws and rules presently in force for what is not mentioned in this handbook; we advice to perform them at least once a year to maintain the boiler's performance.

Appliance booklet or central plant booklet

All appliances must have an appliance booklet (for outputs less or equal 35 kW) or a central plant booklet (for outputs more than 35 kW). All maintenance and servicing operations and combustion checks must be written on the booklet, together with the name of the person responsible for servicing.

Combustion checking



















Combustion checking consists of a control of the boiler efficiency. Boilers that, after the checking, will have efficiency rates lower than the ones required and not changeable with suitable adjustments (that must be performed by qualified technicians), must be replaced.

Boiler operation and servicing









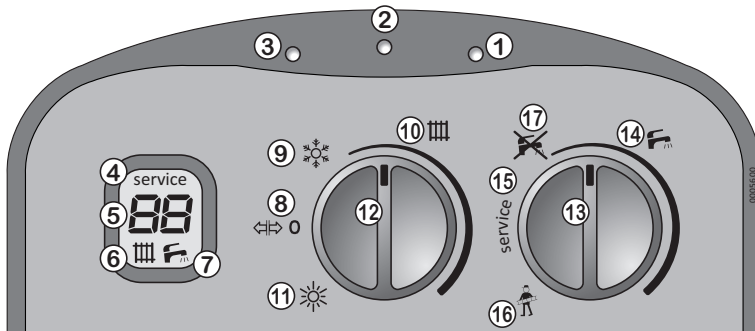





The user (owner or tenant of the flat where the boiler is installed) or the administrator of the block of flats (in case of a central heating system) are responsible for the appliance operation and servicing; they can both transfer the responsibility of the servicing and eventually of the operation to another person, which must be a qualified technician as indicated by the Laws. Even if the user or the administrator decide to assume personally this responsibility, ordinary servicing of the warm air heater and combustion checks must be anyway carried out by a qualified technician



The front control panel

- 1**  **Electrical Supply Indicator Light**
green **Off** - boiler not electrically supplied.
Blinking - boiler electrically supplied, but not active because the knob **12** is on $\leftrightarrow 0$.
On - boiler active. Knob **12** on , or on  along the scale .**Flashing with short pulses** - actuated for mistake, by the user, a *function reserved to the technician*. Rotate immediately the knob **13** back on the scale .
- 2**  **Burner Indicator Light**
yellow **Off** - the flame in the burner is off.
On - the flame in the burner is on.
- 3**  **Alarm Indicator Light**
red **Off** - no problems detected.
Blinking or Flashing - see "Alarms - boiler block" on page 39.
Flashing with short flashes - the user has activated, by mistake, a *function reserved to the technician*. Turn the knob **13** on the scale .
- 4** **service** Indication, on the display, for the Technician, usually not displayed.
- 5** 2-digit number on the display Normally it indicates, in °C, the **measured temperature** of the heating system flow or of the DHW storage (when the relevant symbol  **6** or  **7** flashes).
During the adjustment of the heating system temperature (rotating the knob **12** along the scale ) or domestic hot water (rotating the knob **13** along the scale ) **it shows the set value**, in °C.
When the knob **13** is turned on  **17**, it is displayed "--".
- 6**  -  Usually, they are shown in **fixed mode** and they indicate that the boiler is ready to supply heat to the relevant heating  or DHW . When the boiler is in Summer mode , **the symbol  is not shown**.
- 7** on the display They **blink** during the actual heat delivery, by the boiler, to the relevant system.



8		Position on which the knob 12 should be positioned to turn the boiler off or to reset a boiler block.
9		Position on which the knob 12 should be positioned to activate the boiler in Winter mode (both Heating and Domestic Hot Water functions available).
10		Scale on which the knob 12 should be positioned to adjust the Heating system temperature (<i>attention: only if the Remote Control Kit is not installed</i>).
11		Position on which the knob 12 should be positioned to activate the boiler in Summer mode (only Domestic Hot Water function available and exclusion of Heating) <i>Remark: if the original Remote Control Kit is installed, it's necessary to leave the knob always on Summer  position to make it work (the heating is managed through the Remote Control: see the relevant documentation).</i>
12	boiler mode	Knob that allows to switch the boiler in OFF mode  8 , Summer  11 or Winter  9 and to adjust the Heating system temperature  10 . If the Outdoor Sensor Kit is installed, see "Outdoor Sensor Kit" on page 51. If the Remote Control Kit is installed, see "Remote Control Kit" on page 52.
13	DHW	Knob that allows to adjust the temperature of the water in the storage (along the scale  14). About the hot water temperature, see also "Commands related to Domestic Hot Water" on page 9. The use of the positions 15 and 16 is reserved to the technician.
14		Scale on which the knob 13 should be positioned to adjust the Domestic Hot Water temperature in the storage.
15	service	Positions of the knob 13 which use is reserved to the technician.
16	 	Do not turn the knob 13 on these positions.
17		By turning the knob 13 on this position (<i>hot water stand-by</i>), the storage heating is completely deactivated and " - - " is displayed . This allows a considerable gas saving, especially in medium and long term periods in which the hot water availability is not necessary. The storage anti-freeze function remains active. The anti-legionella function is disabled.

Commands on the lower side

- 18 System pressure gauge
- 19 System filling and pressure restoring cock
- 20 GAS cock

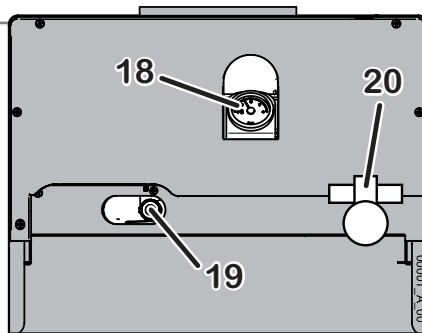

Commands outside the boiler

Externally the boiler, suitably positioned in the building (generally by the installer or by the electrician), two devices that the user should access to, are present. The presence and the characteristics of these devices are prescribed by the regulation in force.

Two-pole switch: it is located usually close to the boiler and it's for electrically insulating the boiler itself from the domestic mains power supply network.

Room thermostat: it commands electrically the boiler to activate or deactivate the heating system, in order to keep the room temperature (detected by a sensor) within a value set by the user, Regulation in force prescribe its positioning, the temperature limits within the user can adjust it and the periods of heating. On trade are available programmable room thermostats: most of them allow to make a weekly programming of various temperature levels, besides special programs for various purposes. We suggest to choose original ITALTHERM accessories.

Commands related to Domestic Hot Water

By the point of view of the domestic hot water, the boiler is designed to be implemented in a system with a domestic hot water storage tank, usually combined with a solar system, that on its turn is normally equipped with suitable commands and indicators to manage the hot water sent to the users.

Only when a storage temperature probe, connected directly to the boiler, is present, the position of the knob **13** along the scale **14** determinates the temperature to which the water in the storage is heated*. If no temperature adjustment devices, downstream the storage, are installed, the knob adjusts the temperature of the water to the user. Otherwise, the knob **13** will affect only the maximum available temperature* and on the "duration" of the availability of hot water. (* in absence of heat input from external systems, e.g. solar). More complex systems can manage directly both the storage temperature (by forcing the boiler to heat the storage, if required) and the temperature to the user. **See the documentation supplied with the system** or ask for information to the installer or to the designer.

(i) A high storage temperature increase the limestone scale of the storage. Also gas consumption depends on the set temperature, aside from the quality of the storage thermal insulation.

Remark: Because of the thermal dissipation along the pipings, it could be necessary a certain time before the temperature of the water out of the faucet gets stabilized.

Typical use

Preliminary operations

- ▶ Firstly, the knob **12** should be on the position $\leftarrow \rightarrow 0$ **8**.
- ▶ Make sure, by the gauge **18** that the **cold-system temperature is always within 0.5 and 1.5 Bar (optimal: 1÷1.5 Bar)**. When the pressure **drops below 0.5 Bar**, the boiler **stops working**. In this case, open the system filling cock **19** up to obtain, on the gauge, a **value between 1.0 and 1.5 Bar**.

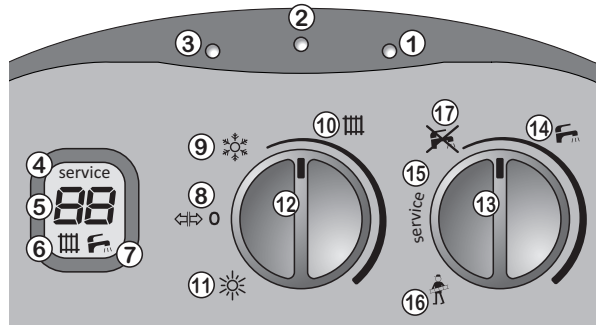

(i) The system pressure raises with the temperature: a too high initial cold-system pressure could lead to **water drain from the 3 Bar safety valve** after the system heating-up.

- ▶ Make sure that the gas cock **20** is open.
- ▶ Make sure that the boiler is electrically supplied: green light **1** blinks.

Boiler activation

- ▶ Rotate the knob **12** on Summer ☀ **11** if you want to have only hot water production, or on Winter ❄ **9** if you need both room heating and hot water production.
- ▶ Opening a hot water cock, the burner ignites and, after a short time (that also depends on the characteristics of the plant externally the boiler) hot water flows from the cock.

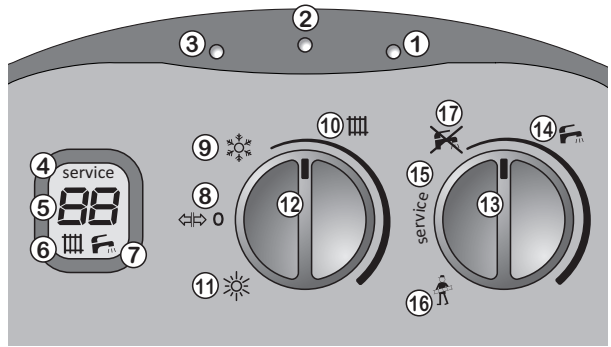

- ▶ In Winter ❄ mode, consequently a request by the Room thermostat, the burner ignites and the produced heat is sent, by means of the system vector liquid, to the heating elements of the building. If, in the mean time, a Domestic Hot Water request takes place, this latter has the priority for the whole request time. Since the DHW requests are usually limited in time, they generally don't affect the room heating.

Temperature adjustment

Note: correct adjustment leads to creating the conditions for energy saving.

- ▶ **Heating system adjustment:** by rotating the knob **12** along the scale **10**, the setting of the heating system temperature is made (the value, during the adjustment, is shown on the display **5**). Generally, in the deep cold season and/or with poor building thermal insulation (or if you notice that the burner stays on for a long time, but the room temperature rises too slowly) prefer higher settings. On the contrary, if you notice that the room temperature exceeds too much, for thermal inertia, the value set on the room temperature, it's appropriate to decrease the system temperature.

Note: if the **Outdoor Sensor Kit** is installed, see also "Outdoor Sensor Kit" on page 51; if the **Remote Control Kit** is installed, see also "Remote Control Kit" on page 52 and the relevant instruction booklet.

Note: don't make confusion between the heating system temperature **10** here described, with the temperature of the room set on the Room Thermostat.

- ▶ **Domestic hot water adjustment:** by rotating the knob **13** along the scale **14**, the setting of the hot water temperature inside the storage, is made (the value, during the adjustment, is shown on the display **5**). About the hot water temperature, see also "Commands related to Domestic Hot Water" on page 9.

Anti-Legionella function

With regular periodicity the boiler, in Summer or Winter mode, automatically provides for the heating of the water in the storage, so as to destroy eventual bacteria (especially *Legionella spp.*) which form in quiet warm water.

Remark: the Anti-Legionella function is not active when the boiler is in stand-by **0** or in "hot water Stand-by" **17** mode.

Incidental malfunctioning







Avoid performing personally any intervention that are job of the technician, for example the ones on the electrical circuits, on hydraulic system or on the gas system, and whatever other operation that's not mentioned in this "User Guide" section and expressly allowed to the User. Always address yourselves to qualified personnel.

Boilers must be always equipped with original accessories only.

ITALTHERM Srl is not responsible for damages caused by the incorrect, wrong or unreasonable use of not original materials.

The burner doesn't turn on

- ▶ if the room thermostat (or programmable room thermostat, or similar) is installed, check that it is really requiring the room heating;
- ▶ check that the electrical power supply is present and that the Summer/Winter  knob isn't positioned on  (stand-by) but on Summer  or Winter . The **GREEN** light should be **steadily ON** (see details in the paragraph "The front control panel" on page 7);
- ▶ if the **RED** locking light was on or blinking, or if you notice an anomalous behaviour of the light indicators, see the paragraph "Alarms - boiler block" on page 39;
- ▶ check on the gauge that the boiler pressure is correct (1÷1.5 Bar in a cold state) or at least **not below 0.5 Bar**;
- ▶ let the technician to look up the notes in the paragraph "Electrical diagram" on page 48.

Shortage of domestic hot water production

- ▶ check that knob  is not set on a too low value or to the "service" position
- ▶ call a qualified technician to check gas valve regulation;
- ▶ call a qualified technician to check, and eventually clean, the coil of the DHW storage.



Remark: where the water hardness value is too high, it is suggested the installation of a softening device, in order to prevent the limestone precipitation; this operation avoids a frequent cleaning of the coil of the DHW storage.

Boiler inactivity

The effects of the periods of inactivity can be relevant in particular situations such as in flats used only for some months per year, most of all in cold places.

The user will have to decide to put the boiler in the **SAFETY SHUT OFF state** disconnecting all the supplies, or to **leave it in stand-by and use the Anti Frost Function**. When there is the possibility of freezing it is convenient to chose between the advantages and the disadvantages of the SAFETY SHUT OFF and of the Stand By/Anti Freezing Way.

Safety shut off

- ▶ Turn off the general switch on the Electrical Supply Line of the Boiler;
- ▶ Close the Gas Tap;



When it is expected that the temperature is going to decrease under 0°C, call a technician to do the following:

- Fill the system, included the primary circuit of the storage unit and the relevant coil, with an anti-freezing solution (unless the system was already filled with said solution) otherwise it must be completely emptied. Notice that if it had been necessary to restore the pressure (because of possible loss) in an heating system already filled with an Anti freezing solution, the concentration of the solution could have decreased and it could not guarantee the Anti freezing Protection.
- let the condense collector syphon be emptied unscrewing its inferior cap.
- completely empty the hot and cold sanitary water system, including the sanitary circuit and the tank of the domestic water storage.

Remark: the boiler is equipped with a system which protects the main components from the exceptional cases of mechanical lock, due to the inactivity in presence of water and scale. The anti-locking function can't work in Safety shut off mode, because of the lack of electrical supply.

(i) Before re-igniting the boiler, have a technician check that the pump is not blocked due to inactivity (for the technician: unscrew the plug in the centre of the cap to access the rotor shaft and turn it with a screwdriver or other suitable tool).

Stand-by mode with anti-frost & anti-locking function

When the boiler is left in stand-by during a period of inactivity, it will be protected against freezing by several functions provided in the electronic controller, which heat the parts involved when the temperature falls below factory set values.

The anti-frost heating is accomplished by turning on the burner and pump.

In addition, when the boiler is in stand-by, it periodically activates the main internal components to avoid rare cases of blockage due to inactivity in the presence of water and lime. This can also occur when the boiler is locked (red lamp on) provided that the system pressure is correct.

In order for these systems to be active:

- the boiler must be receiving gas and electricity;
- boiler must be left in stand-by mode (Summer/Winter knob on $\Leftarrow \Rightarrow \text{O}$, green lamp flashing);
- system pressure must be correct (1÷1.5 bar in a cold state, minimum 0.5 bar)

In case of lack of gas, the burner won't turn on and the boiler will go in LOCK OUT state (red lamp on or flashing). Nevertheless the pump will work, making the water circulate in the system and reducing in this way the possibility of freezing.

(i) ATTENTION: the anti-frost protections cannot intervene in the absence of electricity. If you anticipate this possibility, we recommend you add a good brand of anti-freeze to the heating system, following the producer's instructions.

We recommend to ask directly the installer/technician about the type of antifreeze product put in the heating system during installation.

When the power comes back on, the boiler will check the temperature measured by the two probes and, if it suspects freezing verified by a particular automatic control cycle, alarm 39 will be triggered. For more details, see the relative description in the paragraph "Alarms - boiler block" on page 39.

(i) We recommend that you completely empty the hot and cold sanitary water system, including the sanitary circuit and the tank of the domestic water storage. The anti-frost function does not protect the sanitary circuit outside the boiler.

“Ambient Anti-Frost” Function

Note: if you want to use the “Ambient Anti-Frost” function that is often available in common room thermostats or chronothermostats, it is necessary to leave the boiler in Winter ❄️ mode and NOT in stand-by.

(i) The “Ambient Anti-Frost” function does not protect the sanitary circuit outside the boiler and, especially, in areas where the heating system doesn’t reach. For this reason, we recommend that you empty the cold and hot sanitary system, including the tank of the domestic water storage, if they were at risk of freezing.



Installation

Law and regulation prescriptions for the installer

Note for the translator/writer: Place in this paragraph all the recommendations relevant to the compliance with laws in the destination nation/country (if any). As an example (from Italian regulation):

Characteristics of the room: as this boiler has an heat output lower than 35 kW (about 30000 Kcal/h), it is not required to install the appliance in a dedicated room, provided that the room complies with the regulation in force and that all installation rules assuring a safe and regular gas boiler operation, are strictly respected.



Permanent ventilation of the installation room is mandatory and extremely important when a boiler with air draught from the installation room (B... appliance type) is installed. Ventilation must be made and sized in compliance with Laws and Rules in force.

Instructing the user: at the end of the installation, the installer must:

- explain the operation of the boiler and its safety devices to the user;
- give this user this booklet and the documentation within his/her competence, duly filled in where required.

Dimensions and connections

(i) If the Storage Unit is not installed in the same moment of the boiler, remember to **close the Flow to Storage and Return from Storage connections**, to allow the filling and pressurization of the heating system.

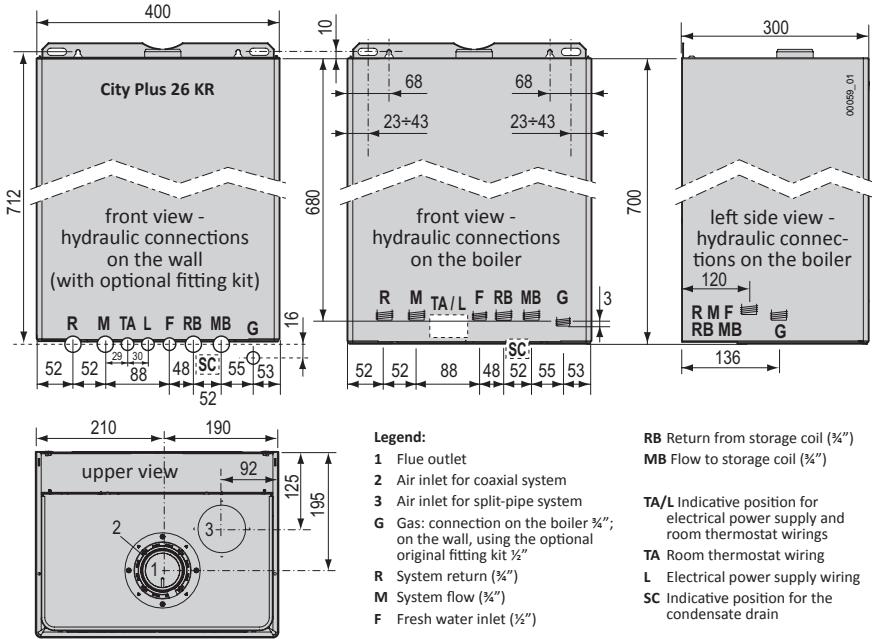

Pump capacity diagrams

(i) The grey area in the diagram represents the correct working range for the boiler-storage system. We recommend to avoid a flow below 800 litres per hour because, if so, the production of hot water could require longer time.

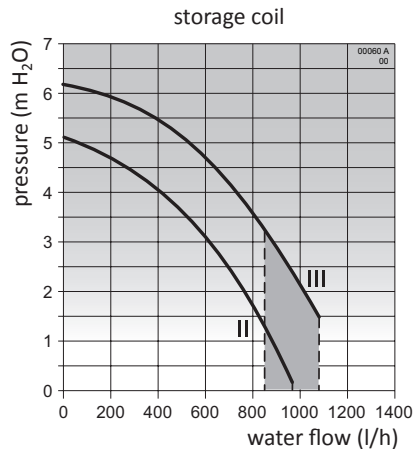
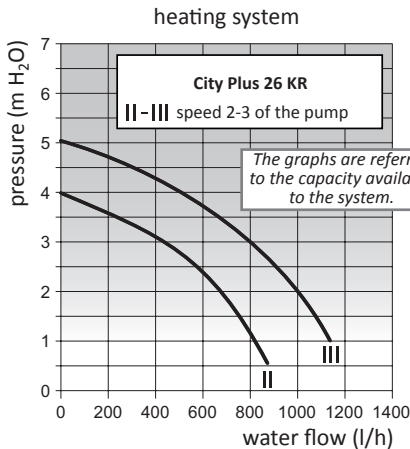

Warnings for the installation of optional kits or special systems

Floor heating system

(i) The safety thermostat(s) that protects the floor against overheating (that could damage the cladding, the structure or the system itself) must be installed on the flow starting end of the serpentine embedded in the floor itself. It should not be installed on the system flow pipe in proximity of the boiler, otherwise frequent and unjustified boiler locks, caused by its triggering, are possible.

Specifications for inlet air

Air must be withdrawn from places free of pollutant (like fluorine, chlorine, sulfur, ammonia, alkaline or similar agents). In the event of installation of the boiler in atmospheres with not negligible presence of aggressive chemical substances (e.g. hairdressing salons, laundries) we recommend to foresee the air inlet from outdoor, choosing the type C installation.

Domestic water supply characteristics

The cold water inlet pressure must be lower than 6 Bar. Besides, for an optimal boiler functioning, water pressure **should be more than 1 Bar.** A lower pressure could make difficult to restore correctly the pressure of the heating system.

(i) In case of higher pressure **it is indispensable to install a PRESSURE REDUCER** upstream the boiler.

The cleaning frequency of the storage coil depends on the water supply hardness. If the water hardness is more than 25° fr it's required to install a softener to bring the hardness below that value.

Besides, the presence of solid residuals or impurities in the water (for example in case of new systems) could compromise the correct functioning of the boiler. For DHW production systems, the regulation in force prescribes a safety filter to protect the systems.

(i) The condensing burner/exchanger assembly requires **particular characteristics for the heating system liquid**, more restrictive than the ones of the inlet domestic water. See the "Heating" section of the table "Technical data" on page 45.

Protection against freezing

Thanks to its antifreeze system, inner components could never reach a temperature lower than 5°C. This system is activated when the boiler is supplied by the electrical and gas lines, provided that the pressure in the heating system is correct.

(i) In case of boiler installation in rooms where temperature can drop down to 0°, it is advisable to fill the heating circuit (included the primary circuit of the storage unit and the relevant coil) with an antifreeze liquid specific for heating systems, propylenic glycol based, following the instructions of its manufacturer. Pay attention to the correct product concentration: adding those substances to the heating water in incorrect dose could lead to the deformation of the seals and cause unusual noises during operation.

ITALTHERM S.r.l. will not be held responsible for consequent damages.

Instruct the User about the antifreeze function of the boiler and about the antifreeze product added in the heating system.

Siphon overflow drain

The boiler's siphon is equipped with a supplementary safety discharge **SCD** that protects the burner in the very situation in which the condense does not flow correctly from the drain pipe downstream from the siphon. Since this is easily accessible from the rear of the boiler, evaluate the opportunity to use it or not **before** installing the boiler, by connecting to it a section of flexible hose **1** suitable for condense. On its other end, the hose **1** should be inserted, avoiding bends and kinks, in a suitable drain, such as the funnel of the condense drain or safety valve. Do not pierce the prepared hole **4**.

As an alternative, although **NOT** recommended, you could simply leave the drain **SCD** open. The burner will anyway be protected if the siphon gets accidentally blocked, but the condense (acid) will leak into the environment and could damage surfaces it touches (such as marble).



Check the seal of siphon, making sure that the caps **2, 3, 5 and 6** are properly and completely screwed/inserted.



Outdoor installation in a partially protected place

“KR” forced draught, condensing models can be installed outdoor, but only in partially protected places.

The boiler minimum and maximum working temperatures are mentioned in the paragraph "Technical data" on page 45 and on the boiler data plate.

The materials used for the boiler installation, including the devices and/or the materials used for thermal insulation, should be so to **maintain their functionality** within the temperature range indicated on the data plate.

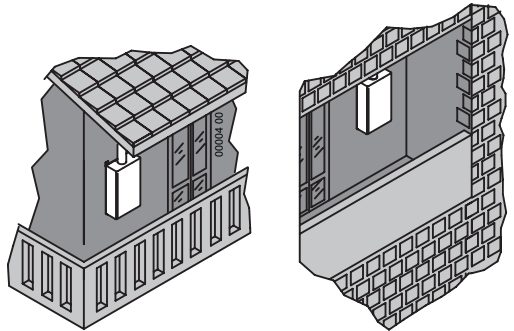

If the place where the boiler is located is converted **from outdoor to indoor** (e.g. veranda) it will be necessary to **verify the compliance** of the new configuration with the laws and rules in force, and to make the modifications required.

Positioning and fastening

Remark: A re-usable metal jig (**D** in the figure) can be ordered separately, so as to facilitate connections and fixing points positioning (when the original connection kit is used). **If the metal jig and/or the original connection kit are not used, refer to the paragraph "Dimensions and connections" on page 14 for the position of the connections directly on the boiler.**

- ▶ Locate the exact position of the boiler considering the sufficient clearances for maintenance and servicing: at least 50mm laterally and 300 mm on the lower side
- ▶ To fix the boiler with wallplugs (“stud” type with nut), centre the relevant wall holes as regards to **A** points. To hang it with open hooks, place hooks in correspondence with **B** points.







- ▶ If the metal jig is used, hang it on the wall using the same wallplugs or hooks and the holes or slots indicated in the figure (**A** for the plugs and **B** for the open hooks).
- ▶ Fix up the connections and all ducts for heating flow and return, storage coil flow and return, cold water, gas and electrical cables, predisposing them in the holes of the metal jig or respecting the measures in the paragraph "Dimensions and connections" on page 14. The upper edge of boiler's body, used as a reference in the paragraph "Flue system types" on page 25, is represented by the dotted line **C** in the figure.

(i) If the Storage Unit is not installed in the same moment of the boiler, remember to **close the Flow to Storage and Return from Storage** connections, to allow the filling and pressurization of the heating system.

- ▶ Remove the jig (if used) and hang the boiler to the wallplugs or hooks, using the holes or slots indicated in the figure (**A** for the plugs and **B** for the open hooks).
- ▶ **Remove the plastic caps** placed to close the hydraulic connections on the boiler.
- ▶ Proceed with the hydraulic, gas, electrical and flue connections following the instructions and warnings reported in the following paragraphs.

(i) The connections of the boiler are engineered to fit plain couplings with screw ring, interposing a plain gasket of suitable size and material, that ensure a reliable seal even without excessive tightening force. They are NOT suitable for hemp, teflon tape or similar materials

Remark: the lower grid is spare inside packing, not assembled. We suggest to fix the grid only at the end of the boiler installation operations.

	Heating Return (3/4")
	Heating Flow (3/4")
TA	Room Thermostat
	Electrical Power Supply
	Cold Water Inlet (1/2")
	Return from storage coil (3/4")
	Flow to storage coil (3/4")
GAS	Gas (1/2")

If necessary, the open hooks can be positioned at any point along the edge **B** of the boiler's frame bracket, provided that they are 2 and that they support the device in a correct and safe way.

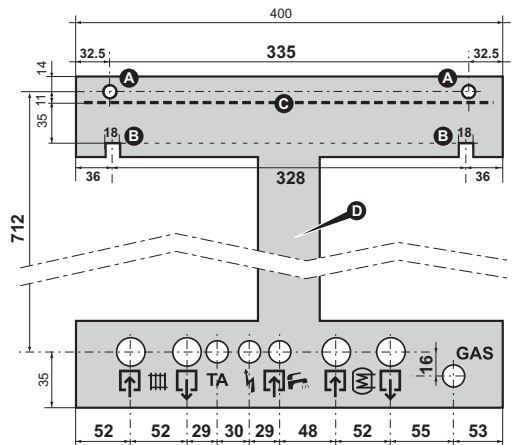
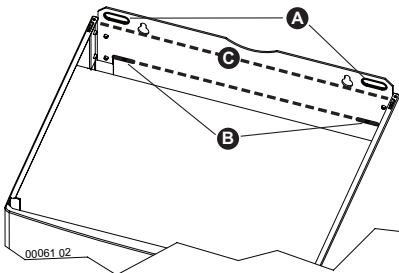

Hydraulic system (DHW and heating)



Make sure that the hydraulic and heating systems ducts **are not used as earth connections of the electrical system**. They are absolutely NOT SUITABLE for such a use. Besides: they don't guarantee the earth dispersion; in case of electrical fault they could generate a fulguration risk; there could take place galvanic currents in the pipings and consequent corrosion and hydraulic leaks.

Advices and suggestions to avoid vibrations and noises in the system

- ▶ Do not use pipes with reduced diameters;
- ▶ Do not use bends with small radius and reductions of important sections.

Cleaning and preservation of the systems

The efficiency, the reliability and the safety of the boilers, as all generic thermal systems and components, depend strictly on the features of the water that supply them and on their treatment.

A proper treatment of the water improves the protection of the systems against corrosions (and therefore perforations, noise, leaks, etc.) and limestone incrustations that drastically reduce the efficiency of the thermal exchange (consider that 1 mm of limestone incrustations reduces of 18% the thermal exchange of the heating element on which it has been formed).

ITALTHERM guarantees its products only if the characteristics of the water comply with UNI 8065, reported also in laws on energy saving.

(i) Thoroughly wash the heating system with water, before connecting the boiler. This will eliminate residual like welding drops, slag, hemp, mastic, mud, rust and other dirt from pipes and radiators. Otherwise, these substances could enter the boiler and damage the internal components (pump etc.).

- ▶ **In case of old or very dirty systems, to wash them use specific, proven efficiency products**, in the suitable quantity and following the instructions of its manufacturer.
- ▶ If the water on boiler inlet is harder than 25° fr, it's required to install a softener to bring the hardness below that value, as required by the reference regulation.
- ▶ For floor system and generally all low temperature systems, the water treatment product must have filming action (protection against corrosion and incrustation) and action against bacteria and algae.

Heating system

- ▶ Connect the safety evacuation ducts of the boiler to an evacuation funnel. If safety valves are not connected to an evacuation device, their intervention could flood the room. The manufacturer cannot be held responsible for any damage arising from that situation.

Piping between the boiler and the storage unit

Link the connection on the boiler identified by **MB** (flow to storage) to the **MB** connection of the Storage Unit, and the **RB** (return from storage) connection of the boiler to the **RB** connection of the Storage Unit.

(i) **Warning:** Swapping the connections could lead to malfunctions. If a recirculation pump is installed, install a check valve.

Condense drain

Insert the flexible pipe of condense outlet inside the outlet funnel (or other inspectable connection device) properly installed for this purpose, or in the outlet funnel of the safety valve, in case of the above mentioned outlet is able to receive the acid liquids of the condense as foreseen by the norms in force in matter of condensing boilers.

(i) The system must be made in order to avoid the condense freezing. Before the activation of the appliance be sure that the condense can be evacuated correctly.

Heating system filling and pressuring

Once all system connections have been carried out, proceed with system filling. This operation should be made with care, respecting the following steps:

- ▶ Open the radiators venting devices;
- ▶ Check that the plug of the automatic air vent, incorporated in the boiler circulator, is unscrewed: if not, unscrew it and leave it unscrewed, even afterwards, for normal operation;
- ▶ If it's required to fill the system with anti-freeze solution, do this operation, then hermetically close the connection or the valve used to put the solution in, to allow the pressurization.
- ▶ Gradually open the filling cock **1** ;
- ▶ Check the correct functioning of automatic venting devices, eventually installed on the heating system and/or on the storage coil circuit;
- ▶ Close the radiators venting devices as soon as water flows out of them;
- ▶ If the storage coil or the relevant circuit were equipped with manual venting valves, use them to purge the residual air from them;
- ▶ Make sure, by reading the pressure gauge **2**, that the pressure reaches the optimal value of **1.0 bar (max 1.5 bar)**;
- ▶ Close the water supply valve **1** and bleed each radiator again;
- ▶ Repeat the venting and pressurization operations until the air is completely purged from the system.

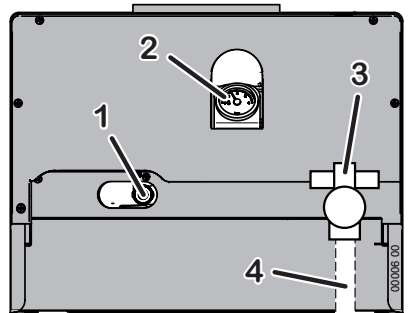

DHW storage tank filling

- ▶ Fill the DHW storage tank (on storage unit):
 - open one of the hot water taps in the DHW system;
 - gradually open the hand valve installed on the cold water inlet of the storage unit;
 - when only water flows out of the tap, close it.

Gas connection

Due to various installation possibilities, the gas cock **3** supplied with the original Connections Kit has a simple male $\varnothing \frac{1}{2}$ " connection, facing the rear of the boiler. *The gas pipe 4, upstream the gas cock 3, should be supplied by the installer.*



While connecting the gas inlet of the boiler to the gas supply piping, it is **MANDATORY** to insert a **PLAIN GASKET**, whose dimensions and material must be adequate. Connection is **NOT** suitable for hemp, teflon strip or similar materials. Because of the type of fitting, the use of those materials does not make the suitable seal with consequent gas leaks!



This boiler is designed and prepared to be supplied with Natural Gas **G20** (Methane) or Commercial Propane **G31**. A qualified technician can convert it to operate with one of these two types of gas above said.

It must never be used with Butane gas G30 (that can be present, pure or mixed with Propane G31, in the portable gas bottles for cookers) therefore, if the boiler is prepared for operation with commercial Propane **G31**, we recommend notifying the supplier of the fuel, for example, by applying the sticker provided with the boiler (or included in the G31 conversion kit), on the gas tank or in its immediate vicinity, so that it is visible to the employee when it is being refilled.



Using Propane gas **G31**, it is absolutely necessary to install a pressure reducer upstream the boiler. Failure to do this, the gas valve of the boiler will get damaged.



The gas connection, as generally the boiler installation, must be done by qualified personnel as prescribed by the regulation in force, because a faulty gas connection could lead to fire, explosion and other very serious damages to persons, animals and objects. The manufacturer cannot be held responsible for any damage arising from that situation.

► Verify what follows:

- cleaning of all system gas pipes in order to avoid the presence of work residuals that could compromise the correct boiler functioning;
 - gas line and ramp conformity with laws and rules currently in force;
 - internal and external tightness of the gas system and connections;
 - supply pipe must have a section greater than or equal to the boiler one;
 - supply gas must correspond to the one for which the boiler has been set: otherwise, it's mandatory to ask to qualified personnel to set the boiler for the correct gas type;
 - an interception valve must be installed upstream the appliance.
- Open the meter valve and purge the air that is inside the system pipes (including all the appliances).

Electrical connections of the boiler



The link of the room thermostat works with a safety extra low voltage (SELV); connect it to the voltage free contacts of the room thermostat/chronothermostat. **On NO account must any electrical voltage be applied** to these terminals.



All low-voltage wirings (e.g. Room Thermostat or Chronothermostat for trade) must be kept separate from power supply cables, as to avoid boiler malfunctioning due to electrical noise. It is advisable to use separate tubes for them.

The boiler must be connected to a 220÷240V - 50Hz electrical power supply. In any case, the power supply voltage must be within the range -15% ... +10% from the nominal value (230V); otherwise it may cause malfunctions or failures. It is necessary to respect the polarities L-N (Live L=brown; - Neutral N=blue) - otherwise the boiler may not work - and the earth connection (yellow-green cable).



Place upstream the boiler a bipolar switch in compliance with the regulation currently in force. The installation must be made complying the regulation currently in force and generally with the standard craft rules.

For the general electrical supply of the appliance the bipolar switch should be used. The use of adaptors, multiple taps and extensions is not allowed.

If the supply cable must be replaced, use one of the following cable types: H05VVf or H05-VVH2-F. **It is mandatory the earth connection in accordance with the rules actually in force.** To replace the cable, open the control panel cover, unlock its fastening device and disconnect it from the terminals. Install the new cable proceeding in the reverse way. When connecting the cable to the boiler, it's mandatory:

- to leave the Earth wire about 2 cm longer than the other (Live and Neutral) wires;
- to lock the cable upstream the terminals by means of the suitable fastening device.



Electrical safety of the appliance is only achieved when it is well connected to an efficient earthing system, executed as indicated by the safety rules actually in force.

A qualified technician must check that the electrical system is in line with the maximum power allowed by the boiler, indicated on the data plate, with particular attention to the cables section.



ITALTHERM S.r.l. declines any responsibility for damages to persons, animals or things caused by the faulty or missing connection of the boiler earthing and by failure to comply with the rules.

Electrical connection between the boiler and the storage unit



Don't connect the storage temperature sensor terminals to the power supply or to live wires.

As shown in "Electrical diagram" on page 48, the boiler has two different inputs for the electrical connections to the storage unit:

TB: input for *storage thermostat* or *solar DHW heating request*: when the contact is closed, the boiler work is forced in DHW storage heating, until it opens (or up to the reaching of the max boiler temperature). To be used in case the storage has a thermostatic temperature control (even manually adjustable) or in connection with a solar system, to allow it to require the heating of the storage when the solar heat contribution is insufficient.

STB: input for a *storage temperature sensor*: the boiler reads the storage temperature and, if necessary, switches to storage heating mode to keep its temperature around the value set by means of the command F_{min} . Even if the storage unit is not supplied by Italtherm, it's necessary to **use the original temperature sensor kit** (NTC R=10 kOhm at 25°C, $\beta=3435$). Only if the **STB input is used**, it's necessary to **remove the factory-installed resistor**, that **otherwise must be left installed**.



The cabling between the storage temperature sensor STB and the boiler must pass in a sheath separate from the ones containing supply cables.

In every case, the maximum length for a 2 x 0.5mm² cable is 30m.

Remark: if both inputs are used, functionally the TB has the priority on the STB.

Flue systems

Installation of the flue inlet/outlet flange gasket



IMPORTANT: For a correct and safe operation of the boiler it's necessary to install, on the inlet/outlet flange **2**, the gasket **1** included in the boiler's documents bag. Before inserting the flue outlet pipe it's therefore very important to correctly place the gasket on its seating as indicated in the figure.

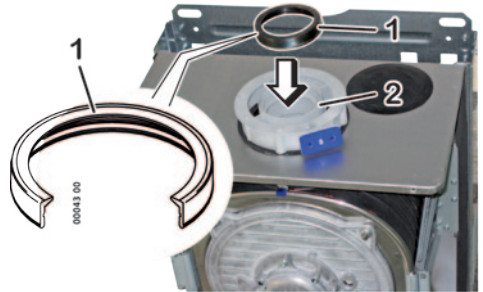

General indications

To grant the functionality and efficiency of the appliance it is indispensable to realize inlet and outlet ducts using flue accessories specific for condensing boilers.



WARNING: the specific flue accessories components for condensing boilers, especially the parts which are in touch with the flues inlet, are so projected because they are made with **plastic materials acids resistant**, but because of their nature, **they are not suitable to resist to the higher temperature** of the flues of the traditional boilers. So it is **not possible to use traditional flue components for the outlet ducts of the condensing boilers, neither vice versa**.



When installing the pipes, we recommend lubricating the inside of their gaskets exclusively with **silicone** lubricants since their material (EPDM peroxide) is not compatible with other types of oils or greases

If it is possible, we recommend to foresee (referring to the direction of the air/flue, see examples on page 26) an upwards slope for all the inlet and outlet ducts, in order to:

- ▶ PREVENT the water or dust or other objects entrance inside the INLET duct. In case of coaxial ducts, use the special horizontal terminal, which is especially built to respect these slopes only for the first tract of the inlet duct;
- ▶ FACILITATE, in the OUTLET duct, the flowing back of the condense towards the combustion chamber, which is built to work in these conditions and to discharge the condense. If so it is not possible, or if there are some points where the condense stagnates inside the outlet duct and if it is not possible to avoid this through a modification of the slope of the ducts, these points must be drained using the specific kit of condense collector (consult the commercial catalogues of the original accessories), and ducting the condense formed towards the outlet duct as foreseen by the norms in force in matter of condensing boilers.

Air inlet and flue outlet terminals should be protected by suitable approved flue accessories, to avoid environmental elements penetration.

Carefully follow the indications foreseen by the specific laws in force.

Respect the minimum and maximum flue length prescribed (see "Flue system types" on page 25).

In case of flue outlet on wall, the positions and the distances prescribed by the regulation must be respected.

The **outlet duct is the assembly of components that connect the boiler to the point where the flues are discharged**. The outlet can be directly outdoor only in the case foreseen by the law in force and using at the end of the outlet duct a specific terminal.

In case you foreseen to discharge the combustion products through a **chimney** (for single user) or a **common flue** (for multiple users) the part of the evacuation system (the chimney or the flue) to which the outlet duct of the condensing boilers is connected, **must be declared suitable for this purpose by its producer**. In case of common chimney, keep in mind the laws in force regarding the typologies and rates of users.

Don't lean the flue pipe into the chimney, but stop it before the inner surface of the chimney. The axis of the flue pipe must intersect the axis of the chimney or of the flue duct.

In general situations the **evacuation systems** of the combustion products **must be properly declared suitable from the producer of the same system** for wet functioning, **or must be supplied by the appliance's producer** (gas boiler).

If the chimney (or the flue) were not suitable, it would be indispensable, to use it, to canalise it through specific ducts, so for example through the original flue accessories.

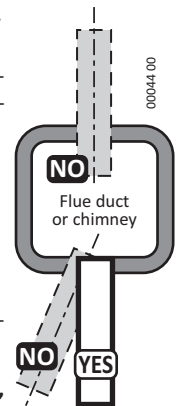

Dimensioning the inlet and outlet ducts

In the list that follows, you will find the characteristic losses of load of the original fume venting accessories, expressed as equivalence in meters (m).

(i) Se fossero previsti accessori di fumisteria originali aggiuntivi rispetto a quelli raffigurati, nel calcolo della lunghezza totale devono essere considerate le relative perdite di carico equivalenti, espresse come equivalenza in metri (m) nell'elenco seguente.

In the case where pipes are installed with non-original accessories (this is allowed by the boiler's C6 type-approval), **but, in any case, absolutely certified for condensation**, the installer must consider the losses of load specified by the manufacturer of these accessories, dimensioning the suction and discharge system so that the total loss of load (expressed in Pa) is between the head loss values of the boiler fan specified in the paragraph "Technical data" on page 45.

Original accessories for separated systems (advised even for type C6):

Connector between boiler and Ø80mm inlet pipe	0.3 m - 2 Pa
Connector between boiler and Ø80mm outlet pipe	0.7 m - 5 Pa

Separate system Ø 60 mm (original accessories):

Reduction from Ø80mm to Ø60mm on inlet	0.4 m
Reduction from Ø80mm to Ø60mm on outlet	1.7 m
Linear section or extension Ø60mm length 0.5m on inlet	0.5 m
Linear section or extension Ø60mm length 0.5m on outlet	0.5 m
Linear section or extension Ø60mm length 1m on inlet	0.9 m
Linear section or extension Ø60mm length 1m on outlet	1 m
Linear section or extension Ø60mm length 2m on inlet	1.8 m
Linear section or extension Ø60mm length 2m on outlet	2 m
90° bend Ø60mm on inlet	1 m
90° bend Ø60mm on outlet	1.6 m
45° bend Ø60mm on inlet	0.5 m
45° bend Ø60mm on outlet	0.8 m
T-shaped condense collector Ø60mm on discharge	3 m
Inlet terminal Ø60mm (length 1 m)	1.4 m
Horizontal outlet terminal Ø60mm (length 1 m)	1.4 m
Vertical outlet terminal Ø60mm (length 1 m)	1.3 m

Coaxial system Ø100/60mm (original accessories):

Flanged coaxial connector Ø100/60mm (starting vertically)	0 m
Flanged coaxial 90° bend Ø100/60mm (starting horizontally)	2 m
Coaxial linear section or extension Ø100/60mm (length 1 m)	1 m
90° coaxial bend Ø100/60mm	2 m
45° coaxial bend Ø100/60mm	1.5 m
Horizontal condense collector Ø100/60mm	0 m
Horizontal inlet + outlet coaxial terminal Ø100/60mm (length 1 m)	1.5 m
Vertical inlet + outlet coaxial terminal Ø125/80mm (length 1 m, connector Ø100/60mm)	1 m

Flue system types

Split pipe system (C₄₃, C₅₃, C₈₃, C₉₃ *)

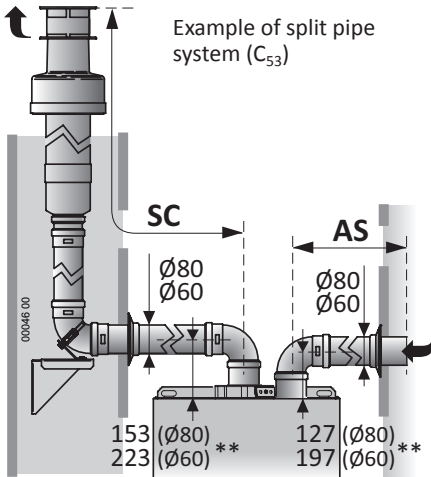

Mod.	Original*** split pipe system Ø80mm	
	AS+SC min÷max (m)	SC max (m)
26 KR	1 ÷ 52	51

Mod.	Original*** split pipe system Ø60mm	
	AS+SC min÷max (m)	SC max (m)
26 KR	1 ÷ 15	14

* Remark: Split pipes allow to make also C₁₃ and C₃₃ flue systems.

** The dimensions on the duct axis are referred to the upper edge of the boiler's body, close to the mouth of the first 90° bend. The difference of level due to the slopes are not considered.

*** **IMPORTANT:** this table is referred to the original flue accessories. Using **non-original** flue accessories (certified for condensation, whose use is allowed by the boiler's C6-type certification) refer to paragraph "Dimensioning the inlet and outlet ducts" on page 24.

Coaxial system (C₁₃, C₃₃)

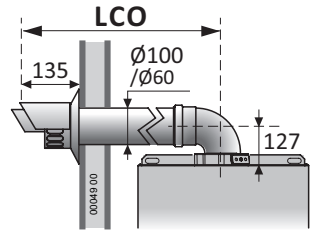
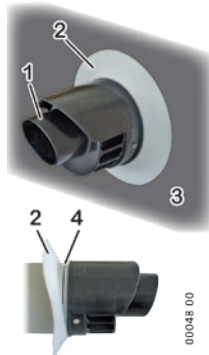
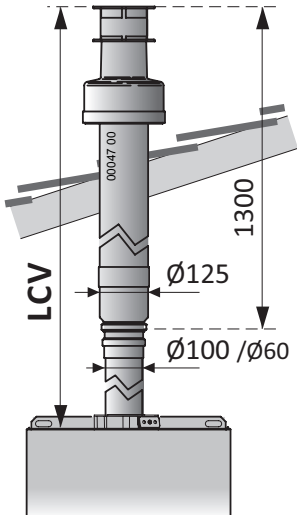

Example of horizontal coaxial system (C₁₃)



Put the outlet coaxial horizontal terminal with the outlet head UPWARDS, as indicated in the picture, respecting the measures in the drawing. Check that the elastic sealing collar is housed in the groove and against the outside wall face.

Mod.	Original*** coaxial system Ø60/100 mm	
	LCO min÷max (m)	LCV min÷max (m)
26 KR	1 ÷ 10	1 ÷ 12

Examples of installation of inlet and outlet ducts

We give you some correct and wrong examples of installation of inlet and outlet ducts for condensing boilers (the slope are voluntarily represented in an exaggerated way).

A = Inlet; **S** = Outlet. **1**: the most functional and economic solution is to let the condense come back towards the boiler. **2-3**: if an obstacle prevents to install the ducts upwards, it is necessary to install condense collectors, so as to avoid stagnations. **4**: the slope upwards of the inlet ducts, for their all length or at least only for the external tract, is sufficient to prevent that the rain water reaches the combustion chamber. **5**: so the inlet must not be downwards. **6**: do not let the condense go out from the flue outlet terminal. **7**: the coaxial inlet/outlet duct must be installed so as the flues are upwards, and so the condense discharge itself towards the boiler. The terminal tract with inlet head and outside with an outlet out axis must be horizontal placed and it is equipped with ribs which prevents the water entrance in the external inlet duct. The internal outlet duct is upwards and canalises the condense in the correct direction.

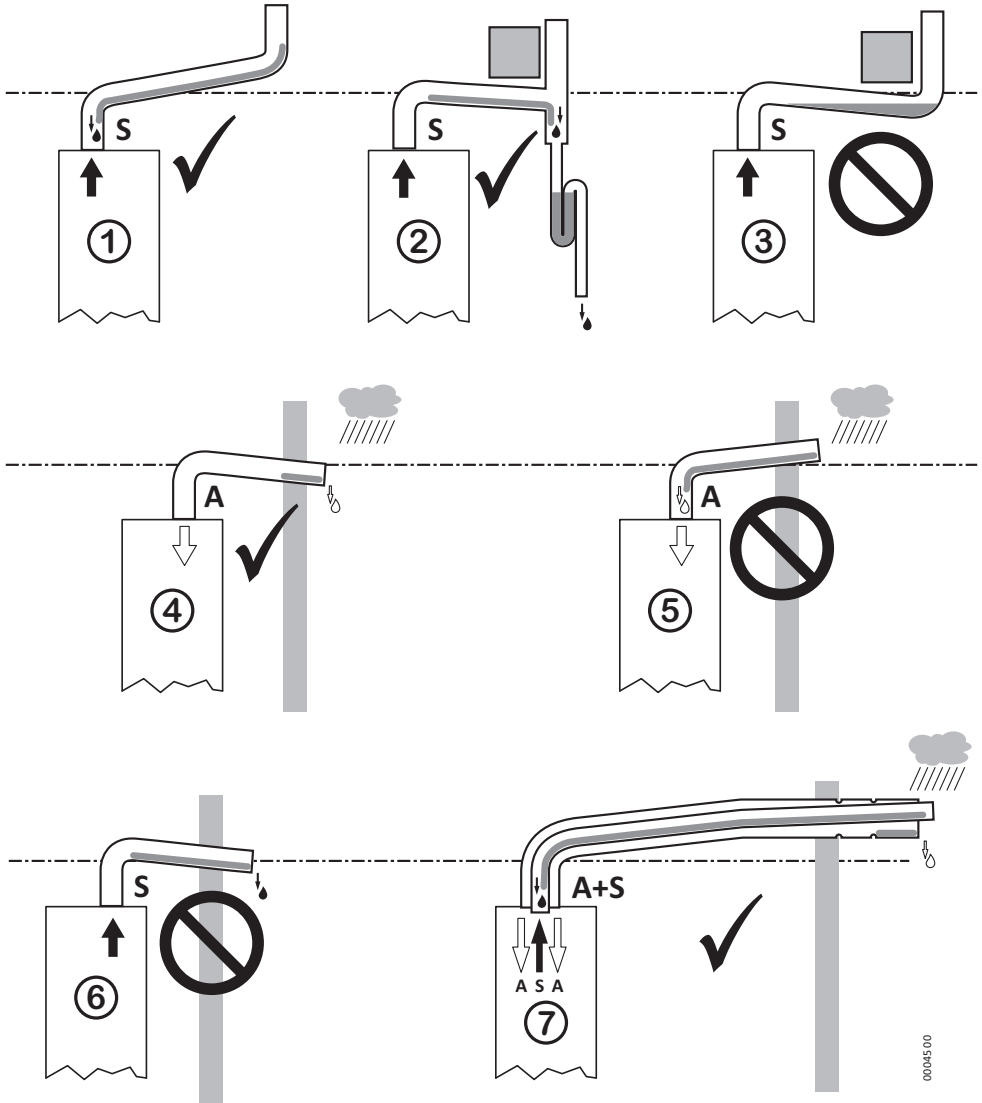

0004500



Adjustment and Maintenance



WARNING: Hereby described operation can be performed by qualified technicians only.



When regulation/measuring is over, remember to tighten pressure tapping point screws and to verify the absence of gas leakages only from net pressure plug (PIN, see the picture of the gas valve) and from the connection upwards the gas valve.



The gas valve, exception the PIN plug and the upwards connections, works in NEGATIVE PRESSURE. We do not recommend to use products for the detection of the gas leakages where not expressly indicated, because these products could penetrate inside the gas valve disturbing its normal functioning.



Do not use free flames to detect gas leakages!



The siphon is an integral part of the combustion system and it's necessary to check its seal during every technical intervention on the boiler. Verify that both caps (upper and lower) are properly and completely screwed.



Verify that the combustion products do not go out from the outlet of the condense.



The condense syphon trap of the boiler is equipped with a special device which closes when dry. Anyway, the seal is guaranteed only when the syphon trap is filled with liquid. So, at the end of the first firing / commissioning operation, it is recommended to check that the syphon trap contains liquid, e.g. checking that liquid exits the condense drain of the boiler.



Before firing the boiler, **check that the circulator is not blocked** due to inactivity: **unscrew the plug** in the centre of the cap to **access the rotor shaft** and manually **rotate it** using a screwdriver or other suitable tool.



During the commissioning of the **new boiler**, it is necessary to **run the burner for 30 minutes before checking the combustion** because, in that period of time, any residual fabrication vapours could cause false results in the combustion products analysis.

Remark: during the first 10 minutes of electrical power supply, the re-ignition delay in heating mode might be nil (see "Electronic settings" on page 35, SW3).

- The knob  on control panel has the position "service" that is used only during the regulation of the MAX heating power.
- The ignition electronics does several ignition attempts, to avoid blocking the boiler when the ignition fails sporadically.
- When the gas supply pipe is filled with air (e.g. in case of new installation) it may be necessary to repeat the ignition cycle several times.
- The boiler is factory regulated and tested. Anyway it's advisable, during the commissioning, to check that the regulation is correct.

First starting up

The first ignition operations consist in verifying the correct installation and functioning, and in the eventual regulations which are necessary:

- ▶ verify that the data of the plate correspond to those of the net supply (electrical, water, gas);
- ▶ verify the absence of the gas leakages from the connections upwards the boiler;

- ▶ verify the proper realization and the efficiency of all the boiler connections (water, gas, heating system and electrical system);
- ▶ verify the presence of the permanent air/ventilation outlets, correctly dimensioned and working, as foreseen by the National and Local laws depending on the appliances installed;
- ▶ verify that the evacuation flue duct corresponds to the National and Local laws and that is in good and efficient conditions;
- ▶ verify the correct functioning of the system of the outlet condense, also in the external parts of the boilers, i.e. the eventual condense collector installed on the flue outlet: verify that the liquid flow is not obstructed and that there are not inlets of gaseous combustion products inside the system itself;
- ▶ verify that the passage of the air burning and the evacuations of the flues and of the condense will be made correctly accordingly to National and Local laws in force;
- ▶ verify that the conditions for the air ventilation are granted, in case of a boiler placed inside a piece of furniture;
- ▶ vent the primary exchanger, proceeding as described in the paragraph "Venting the primary exchanger" on page 30;
- ▶ verify and, if necessary, change the boiler electronic settings to adapt its work to particular system requirements (see "Electronic settings" on page 35);

(i) Before turning on the boiler, verify that the pump is not blocked due to inactivity: unscrew the cap located at the centre of the pump's body, locate the rotor shaft behind the cap and turn it manually using a screwdriver or other suitable tool.

- ▶ verify that the combustion is correctly regulated: go on in this chapter as described in the paragraph "Combustion test and adjustment" on page 32;

(i) During the first ignition of the brand new boiler, it is necessary that burner works for at least 30 minutes, before performing combustion checks. During this time, the fumes of the eventual residual manufacturing materials are produced, and they could alter the measured values.

- ▶ verify the correct functioning of the boiler in heating and domestic hot water version;
- ▶ fill in the foreseen documentation and leave to the user the copy of his competence.

Maintenance operations

The periodically maintenance operations consist in cleaning the main parts of the boiler, in the further functioning proof (especially those described by the laws in force), and in the eventual regulations, which could be necessary:

- ▶ verify the absence of the gas leakages from the connections upwards the boiler;
- ▶ verify the conformity, efficiency and good conditions of the connections to the boiler (water, gas, heating and electrical system);
- ▶ verify the presence of the permanent air/ventilation outlets, correctly dimensioned and working, as foreseen by the National and Local laws depending on the appliances installed;
- ▶ vent the primary exchanger, proceeding as described in the paragraph "Venting the primary exchanger" on page 30;
- ▶ clean the burner, the exchanger and the funnel of the condense: go on as described in the paragraph "Combustion group cleaning" on page 30;
- ▶ check that the internal parts of the boiler are in good condition and clean;
- ▶ verify that the passage of the air burning and the evacuations of the flues and of the condense will be made correctly according to National and Local laws in force;

- ▶ verify the correct functioning of the system of the outlet condense, also in the external parts of the boilers, i.e. the eventual condense collector installed on the flue outlet: verify that the liquid flow is not obstructed and that there are not inlets of gaseous combustion products inside the system itself;
- ▶ verify that the conditions for the air inlet are granted, in case of a boiler placed inside a piece of furniture;
- ▶ when prescribed, or if it is necessary (i.e. if you find excessive residual in the combustion group or in the funnel of the condense), verify that the combustion is correctly regulated: go on in this chapter as described in the paragraph "Combustion test and adjustment" on page 32;
- ▶ verify the correct functioning of the boiler in heating and domestic hot water version;
- ▶ fill in the foreseen documentation and leave to the user the copy of his competence.

Access to the inside of the boiler

1. Unscrew the screws **1** and remove the lower grid **2**, if any;
Remark: Lower grid is spare inside packing, not assembled.
2. Push the casing **3** upwards and remove it;
3. unscrew the two screws **4** and overturn downwards the control panel **5**;
4. after the regulations, close the boiler repeating everything in the other sense, carefully hooking the casing **3** to the tongues **6**.

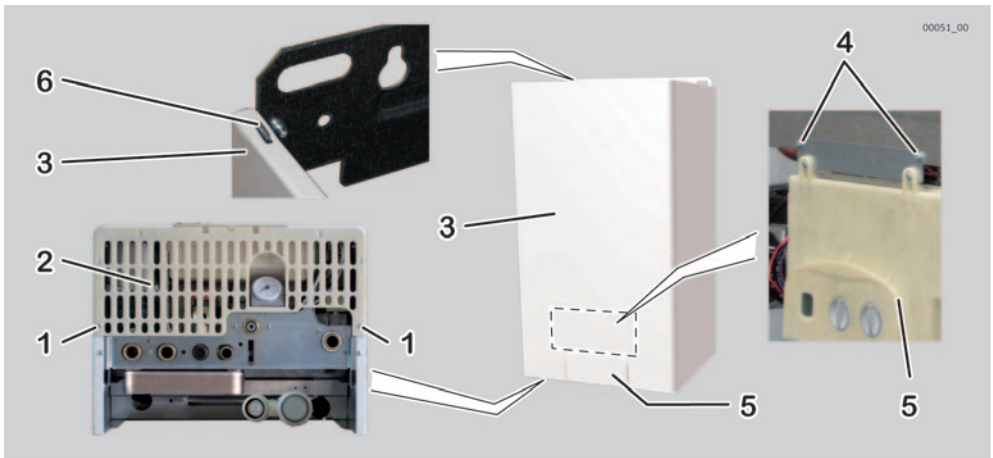

Venting the primary exchanger

When commissioning and cleaning the combustion unit, it is a good idea to check that there is no air in the primary circuit of the combustion unit and, if necessary, to eliminate it by opening the valve **4** located on the top of the unit.

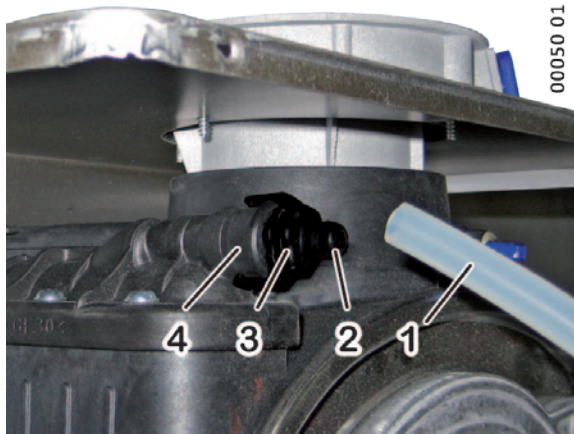

- ▶ To avoid wetting the sealed chamber inside, use a length of flexible hose **1**, with suitable diameter, on the fitting **2**;
- ▶ slowly open the venting valve by manually turning the ferrule **3** counter-clockwise;
- ▶ when no more air comes out, close the venting valve by manually turning the ferrule **3** clockwise, without forcing excessively.

Combustion group cleaning



Switch off the boiler and disconnect it from the electrical supply.



Be sure that the parts are not hot and eventually wait the time necessary to cool them;



Because some contacts with the fine dust and acid condense may occur, we recommend to wear the proper devices for the personal protection (i.e. glasses, gloves, masque)



Warning: do not wash or damage the insulating coverings inside the combustion chamber.

- ▶ Open the sealed chamber;
- ▶ disconnect the two fan connectors **10**;
- ▶ disconnect the connectors **12** from the ignition electrode **2** and from the flame detection electrode **13**. **Attention:** do not dismantle the electrodes from the combustion group;
- ▶ unscrew the screw **6** and take away the support **5**; unscrew the nut **7** which fixes the gas pipe **4** to the gas valve; pull out the gas pipe from the fan/air-gas-mixer assembly;

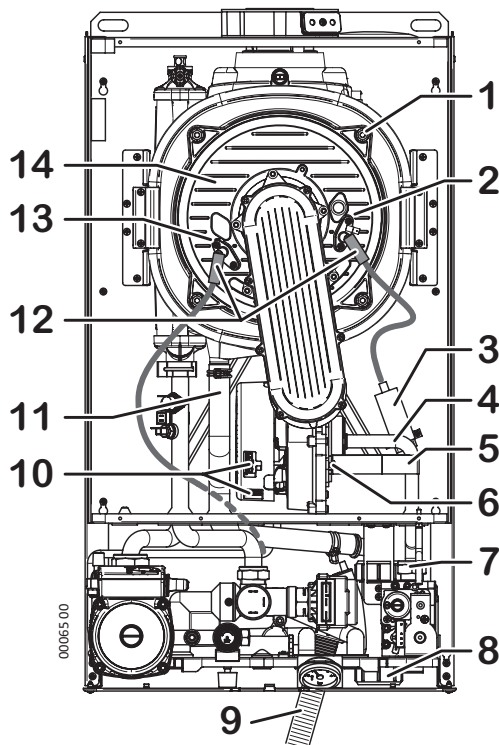

- ▶ unscrew the 4 nuts **1** which fix the burner group **14** (composed of fan, hose and burner) to the primary exchanger. Remove the burner group;

(i) Do not disassemble the burner group and do not dismount the ceramic fibre plate from the bottom of the exchanger.

- ▶ check the integrity of the insulating coverings inside the combustion chamber;
- ▶ on the burner cover, check the integrity of the fireproof fibre gasket and of the silicone rubber one;
- ▶ check that the burner do not present deposits, foulings or excessive oxidations and that all the holes are free;
- ▶ clean softly the burner electrodes, avoiding to bend it or to move it;
- ▶ clean the cylinder of the burner **ONLY IF IT IS NECESSARY** and only **DRY**, through a **NOT METALLIC** brush, with movements on the burner's axis, from cover outwards;

(i) Do not damage the insulating coverings inside the combustion chamber and don't deform the holes of the burner. If the burner works correctly, it will be of black colour but clean or in any case with few deposits, not scaled and easy to remove.

- ▶ slip off the outlet condense pipe **11** from the connection on the primary exchanger. It's advisable to plug on the connection a suitable pipe, to divert outside the boiler (and especially out of the condensate syphon) the dust that detaches from the primary exchanger during the cleaning;
- ▶ **to clean the primary exchanger:**
 - prior to brushing the exchanger's coils, carefully remove, by a powerful vacuum cleaner, the solid residuals of combustion; don't use air jets;
 - then clean the primary exchanger coils by a **NOT METALLIC** brush and remove the residuals again by using the vacuum cleaner;

- ▶ locate the lower cap **8** of the siphon (where you can access from the lower side of the boiler, behind the returned connector of the system), put a collector for liquids under it. Unscrew the cap. Let the siphon empty itself. Inside the cover a layer of residual could be present (max 1÷2mm): remove it;



Remark: *an excessive quantity of residual is an indicator of malfunctioning or in any case it is not a normal situation. Locate the reasons and solve the problem, so remove the siphon unscrewing the superior and lateral connectors, and the screw of its support bracket. Accurately clean the siphon and be sure that its condense inlet pipe **11** and condense outlet pipe **9** are clean and not obstructed.*

- ▶ Reassemble all the components in the backwards order and opposite sense and check the combustion.

Combustion test and adjustment

(i) Before checking the combustion, clean the burner and the exchanger as described in the paragraph "Combustion group cleaning" on page 30 (except for the case of first ignition).





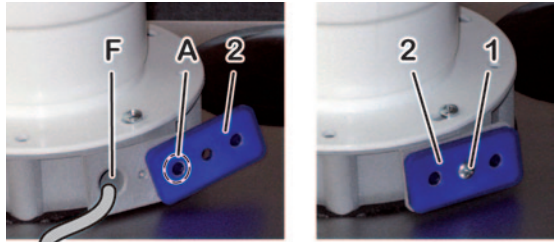

To check and adjust the boiler you need a **flue analyser, correctly calibrated** (in the condensing boiler, the precision and the correctness of the measures is particularly important). Then, through a suitable function on the panel, we ignite the burner, first with a reduced flow and then at the maximum flow, doing the measure and adjustments in both conditions. Proceed as follows:

1. Put the boiler in stand-by turning the "Summer/Winter" knob  on  (green lamp flashing);
2. on the flue flange, unscrew the screw **1** and move the tapping insert **2** in such a way to tap the inlet plug **A** only; insert the analyser sensor in the flue plug **F**, taking care of the seal of the connection;



Remark: The device placed at the top of sensor must be placed as possible in the centre of the flow outlet: we advise you to insert well the sensor and so to extract it of 3 cm. Insert the sensor so that the protection bow of the sensor, placed at the top, is transversal (the flow must pass through it and directly touch the sensor).

(i) Generate a heating request by activating the room thermostat. Be sure that the heat produced by the boiler can be eliminated by the heating system through the radiators and/or radiant panels/floor systems.

3. turn the Summer/Winter knob  to Summer position ;
4. turn the "Hot Water" knob  on the "chimneysweeper"  symbol and wait (about 5 seconds) that the display shows "SE" (SErvice) flashing (besides, the **green** lamp flashes with short lightnings);
5. when the display shows "SE" flashing, turn the Hot Water knob  on the beginning of the scale  (burner ignition at the minimum power output). The **service** indication appears on the display, to indicate that the function is active. Besides, the **yellow** lamp turns on, indicating that the burner is ignited;

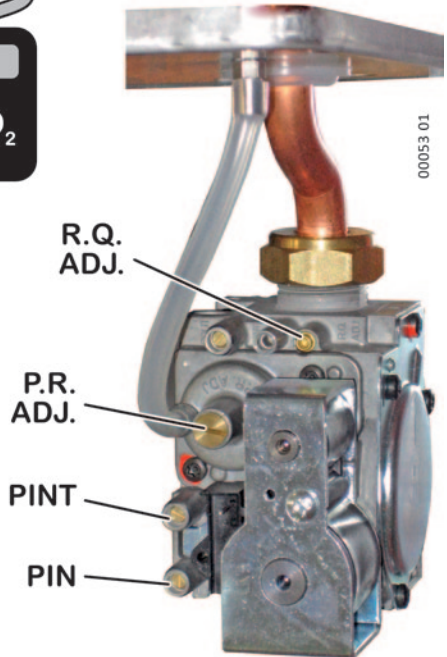

6. making reference to the following table, check that the centre of the display shows the correct value for the **number of revolutions per minute at Qr** for the **type of gas used** (you are reading the number of fan revolutions per minute x100 at reduced flow capacity; for example, the value 14 means that the fan is rotating at 1400 rpm);

Heat input	Natural gas G20		Commercial propane G31	
	CO ₂ %	Fan rpm x 100	CO ₂ %	Fan rpm x 100
Reduced Qr	8.9 ±0.5	14 ... 15	9.6 ±0.5	15 ... 16
Nominal Qn	9.1 ±0.5	57 ... 58	10.0 ±0.5	58 ... 59

7. the burner ignites at the reduced input. Wait for the boiler to come up to full operation (about 5 minutes). If the value of CO₂ in the fumes, at the reduced input **Qr** for the **type of gas used**, is within the range shown in the table, go to step 8 to check/adjust the nominal input, otherwise you will have to bring the CO₂ back within the correct values, changing the offset by turning the screw **P.R. ADJ.** (the adjustment screw is inside the bushing, under the screw cap). **ATTENTION: turn the screw 1/8 of turn at a time and then wait 1 minute** to allow the CO₂ value measured by the analyser to stabilize;
- If the CO₂ value is **HIGHER** than allowed, **DECREASE** the off-set by turning the screw **P.R. ADJ. COUNTERCLOCKwise**;
 - If the CO₂ value is **LOWER** than allowed, **INCREASE** the off-set by turning the screw **P.R. ADJ. CLOCKwise**;
8. turn the Hot Water knob **F_m** fully clockwise to the end of the scale **F_m** (burner ignition at the maximum power output);
9. check that the centre of the display shows the correct value for the **number of rpms at Qn** for the **type of gas used** (rpm x100 at nominal flow capacity; for example, the value 57 means 5700 rpm);
10. the burner ignites at the reduced flow capacity. Wait for the boiler to come up to full operation (about 5 minutes). If the CO₂ value in the fumes at nominal input **Qn** for the **type of gas used** is between the values shown in the table, turn the "Summer/Winter" knob **III** on **⇄** to quit the programming mode and turn off the boiler, otherwise you will have to adjust the gas input by turning the screw **R.Q. ADJ.** . **ATTENTION: turn the screw 1/4 - 1/2 of turn at a time**, waiting 1 minute for the values measured to stabilize:
- If the CO₂ value is **HIGHER** than allowed, turn the screw **R.Q. ADJ. CLOCKwise**;
 - If the CO₂ value is **LOWER** than allowed, turn the screw **R.Q. ADJ. COUNTERCLOCKwise**;

Remark: if you have adjusted the CO₂ at the nominal input, we advise you to check again the CO₂ and the off-set at the reduced input (steps 3 to 7).















IMPORTANT: at the end of the check or the adjustments, it is INDISPENSABLE:

- close, on the gas valve, the pressure plug **PINT** by turning the specific screw;
- close the flue plugs used, by restoring the tapping insert **2** and the screw **1**, caring that the plastic surface of the flange is not damaged or worn;
- seal the screw cover of **P.R. ADJ.** and the screw **R.Q. ADJ.** if they have been used;
- check the correct flue system tightness, especially the tightness of the tapping insert **2**.





Max heating power adjustment

The maximum heating power output must be set in accordance with the system requirements (stated in the project). Power input values, corresponding fan rpms and relevant display indications are listed in the "Power input / display / fan rpm table" on page 35.

The adjustment will be performed through the boiler's controls, following a special procedure that avoids accidental activations by the User:

1. get information about the maximum heating power requirement of the heating system (reported on the project documentation of the system itself);
 2. supply the boiler and turn the Summer/Winter knob  to Summer position ;
 3. ensure that there are NOT domestic hot water requests (no open taps); if the room thermostat is installed, make so that it requires the heating (e.g. raise the requested room temperature manually);
 - turn the Hot Water knob  on **service** position: on the display will appear a flashing number from 00 to 99 that indicates the current set point of the value of heating power, where the value **00** corresponds to the minimum setting of the gas valve and the value **99** corresponds to the maximum;
 - wait (approximately five seconds) that the display shows "**PO**" (P**O**wer) flashing (moreover, both the **GREEN** and **RED** indicators flash to short "pulses").
 - when the display shows "**PO**" flashing, within 15 seconds turn the Summer/Winter  knob on the **MAXIMUM** value of the scale of the heating  (fully clockwise). The **service** indication appears on the display and the burner ignites to the maximum output not modulated (the **YELLOW** indicator turns on);
 - on the display, the number 99 flashes, indicating the current maximum heating output setting; it's possible to change the maximum power output by acting directly on the Summer/Winter  knob within the scale of the heating ;
- REMARK:** the value from 00 to 99 that appears on the display during the setting, is foreseen to be read at the end of the adjustment and to be eventually re-used as a quick reference to set the boiler again to the same heating power.
- **do NOT move the Summer/Winter  knob for about 30 seconds**, until the number on the display stops flashing (also the **GREEN** indicator stops flashing and stays on). During this time, **check that the pressure displayed on the manometer remains stabilized** on the correct value. If further pressure adjustment should be needed, turn the knob and wait again 30 seconds and the end of flashing;
 - to confirm and save the setting, turn the Hot Water knob  on the scale ; the burner will turn off for a moment. Wait (about 5 seconds) that both the **GREEN** and **RED** indicators stay on for about 5 seconds (this is the confirmation that the burner pressure for heating is stored), then the **RED** indicator turns off;
4. to switch off the burner, turn the Summer/Winter knob  to the  position.

The MAX power for the heating system is now adjusted.

The whole procedure should be completed within 15 minutes from the start. If you exceed this time, or in case of mistakes, the new pressure will not be stored and it will be necessary to repeat the procedure from the beginning, by turning the Summer/Winter knob  on  and the Hot Water knob  on the scale .

Power input / display / fan rpm table

	HEAT INPUT		FAN RPM		INDICATIVE DISPLAY VALUE
	kW	kcal/h	Natural gas G20	Commercial Propane G31	
City Plus 26 KR	MIN. 5.3	4558	1500	1600	0
	7.45	6416	1930	2030	10
	9.5	8187	2360	2460	20
	11.6	9959	2790	2890	30
	13.6	11730	3220	3320	40
	15.7	13502	3650	3750	50
	17.8	15274	4080	4180	60
	19.8	17045	4510	4610	70
	21.9	18817	4940	5040	80
	23.9	20588	5370	5470	90
MAX. 26.2	22532	5800	5900	99	

Electronic settings

Accessing the main board

To access the main board:



Cut off the electrical supply to the boiler. Restore the supply after having closed the control panel rear cover.

- unscrew the screws **1** and remove the back cover of the control panel.

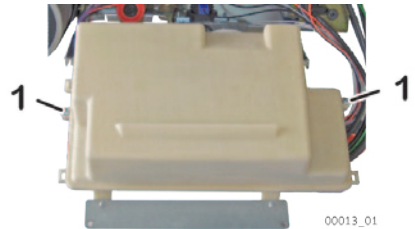

00013_01

Main board settings

The boiler is equipped with a Microprocessor modulation board, featuring a 6-microswitch array (SW1÷SW6) which allow to make personalizing actions for the boiler's functioning as described in the following table.



Disconnect the power supply before approaching the microswitches. Restore the power supply only after you have closed the back cover of the control panel.



Changes to microswitches status have no effect until the boiler is electrically supplied (they are red during the board startup, when the supply is connected).

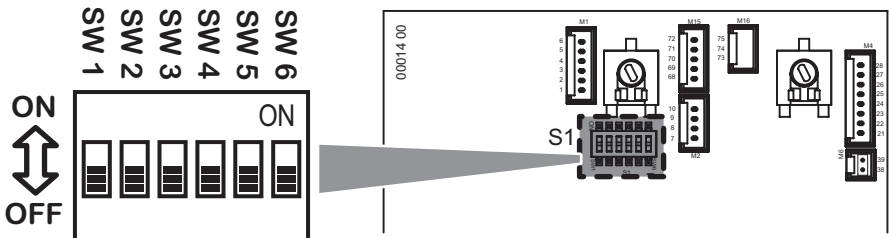

SW1 **OFF** **Natural gas (G20)** Functioning.

ON **Propane (G31)** Functioning.

The factory setting depends on the gas type arranged in factory for the boiler. To change the type of gas supply, it is necessary to follow the complete instructions described in the paragraph "Gas conversion" on page 36.

SW2 Adjustment range for heating system flow temperature.

OFF **Normal** setting, suitable for traditional radiators systems. It allows to select a heating system temperature within the standard range from 35°C to 78°C. **Factory setting.**

Reduced setting, suitable for low temperature systems. It allows to select a heating system temperature within the reduced range from 20°C to 45°C.

ON **Remark:** *If the boiler supplies a mixed type system (high and low temperature) through the suitable optional kit, use the reduced range (ON) (refer also to the documentation supplied with the kit).*

SW3 It determines the delay of 3 minutes, before the new ignition of the burner after the overcoming of the heating set temperature.

OFF **delay ON** (for normal radiators systems). **Factory setting.**

ON **delay OFF** (for fan coil systems).

SW4 It determinates the temperatures for the burner to be turned ON and OFF during the DHW work.

OFF burner OFF at 75°C and burner ON at 60°C. **Factory setting.**

ON burner OFF at the set DHW temperature (T.SET) + 3°C, and burner ON at T.SET + 2°C.

SW5 Pump functioning mode during heating working.

OFF **intermittent** for normal applications (with or without delay, see SW3). **Factory setting.**

always off (external pumps are present).

ON *Remark: The pump will be anyway activated in all other circumstances, e.g. during the DHW functioning, for post-circulation (if foreseen) or for anti-freezing or anti-lockout functions.*

SW6 **OFF** In City Plus Boilers it must be **OFF**. **Factory setting.**

Gas conversion



ATTENTION: the operations described below must be carried out only by qualified personnel [authorized by ITALTHERM S.r.l.].

For gas conversion, use the components supplied by boiler manufacturer only.



Using Commercial Propane G31, it is absolutely necessary to install a suitable pressure reducer upstream the boiler.



This boiler is designed and prepared to be supplied with Natural Gas G20 (Methane) or Commercial Propane G31. A qualified technician can convert it to operate with one of these two types of gas above said.

It must never be used with Butane gas G30 (that can be present in the portable gas bottles for cookers) therefore, it's important to inform, about this, the supplier of the fuel.

1. Disconnect the boiler from the electrical supply. Remove the boiler cover as described in the paragraph "Maintenance operations" on page 28;
2. access the main board and switch **SW1** (see also "Main board settings" on page 35) accordingly with the available gas type:
 - **OFF for Natural gas (G20),**
 - **ON for Propane (G31)**
3. ensure that the inlet gas pressure complies with the required nominal pressure (see "Technical data" on page 45) and that the gas flow is sufficient to guarantee the appliance correct work;
4. open the sealed combustion chamber;
5. slip off the silicone hose **1** from the fitting **2** of the sealed chamber compensation plug;
6. unscrew the calibrated plug **2** and replace it with the one in the conversion kit. The connector to use with Methane G20 is "silver" coloured and the one for Propane G31 is "brass" coloured; then, insert the silicone hose **1** on the sealed chamber compensation plug again;
7. open the sealed chamber, loosen the screw **5** and remove the bracket **6**;
8. loosen the swivel nut **7** that connects the gas tube **4** to the gas valve, and unplug the other end of the tube **4** from the fan **3**;
9. remove the diaphragm **8** by attaching a piece of adhesive tape and lifting it from its seat. **NEVER USE TOOLS**, especially through the calibrated hole!
10. insert the diaphragm from the conversion kit, taking care that **the stamped diameter is facing UPWARDS** and taking care to place it correctly inside the gas valve fitting: it must be flush with the edge, without projecting;

Remark: see "Technical data" on page 45 for the correspondence between the diaphragm diameter and the gas type.

11. insert the gas tube **4** in the fan **3**; reassemble the swivel nut **7** replacing the gasket;
12. remount the bracket **6** and the screw **5**; close the sealed chamber;
13. check, with the burner on, that the pressure upstream from the boiler is:

- **Natural gas (methane) G20** = min.17 - max.25 mbar
- **Commercial Propane G31** = min.35 - max.40 mbar

For detailed setting values, refer to the table "Technical data" on page 45.

14. check the combustion as described in the preceding paragraph "Combustion test and adjustment" on page 32 checking that the fan speed automatically change;

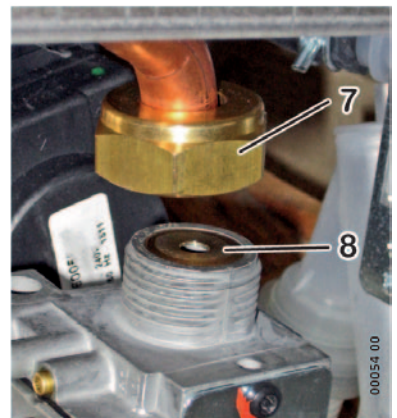
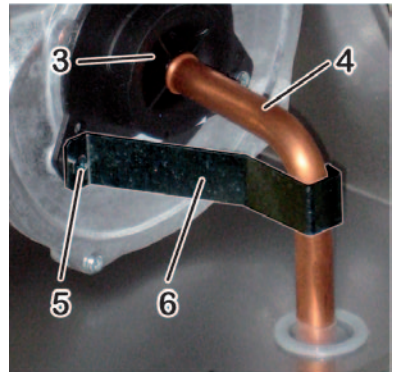
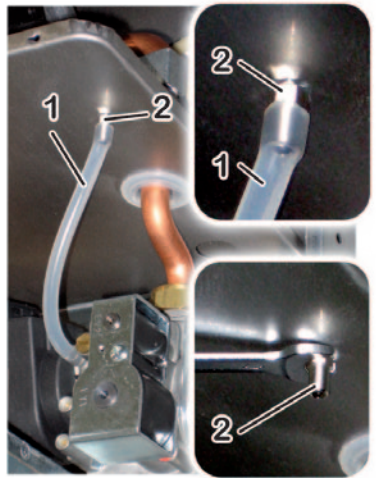

15. apply the label indicating the type of gas (provided with the kit) in the area provided on the “WARNING” plate inside the boiler;
16. in the case of liquid gas fuel, it is important that the boiler be exclusively fuelled with commercial Propane G31 and not with Butane G30. For this reason, we recommend that the supplier of the fuel be informed, for example, by applying the sticker provided in the conversion kit on the gas tank or in its immediate vicinity, so that it is visible to the employee at the time it is being filled.

Hydraulic settings (pump speed)

The pump has a selector which allows to reduce the speed, so as to reduce the noise produced by the too rapid circulation of the liquids in too small heating systems.

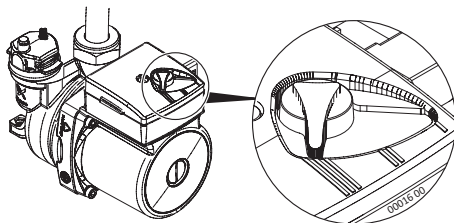

- **III = Maximum Speed** (Factory setting)
- **II = Medium Speed**
- **I = Minimum Speed** (use only if strictly necessary; test the heating system, verifying that no over-heating problems occur).

Draining the heating system



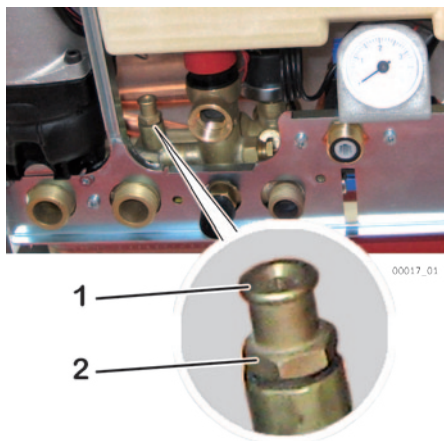

When it is necessary to drain the heating system, proceed as described here below:

- ▶ Connect a rubber pipe to the draining tap terminal **1** ;
 - ▶ put the other end of the pipe in a suitable drain or sink;
 - ▶ open the draining tap by turning the nut **2** counter-clockwise, using a suitable spanner;
 - ▶ when the pressure is COMPLETELY drained, it's possible to open the radiators venting valves, to allow the air inlet. The complete system drain is possible only draining the liquid from the lowest point of the system itself.
 - ▶ when everything is over, close taps (turning the nut **2** clockwise) and air vents.
- (i)** In the primary exchanger a certain quantity of water of the heating system remains. If you want to remove the boiler from the wall, we advice you to close with plugs the hydraulic inlet/outlet heating system connections.
- ▶ Drain the storage unit if necessary (storage tank and/or primary coil). Refer to the relevant documentation.













Alarms - boiler block















Following a malfunction, the boiler can lock-up and show a particular signalling, consisting of an alarm code on the display and of the status of the **RED** light indicator (and eventually of the **GREEN** and the **YELLOW** ones). In the following table, all the alarm signals are listed, their most probable causes and the suggested solutions.













Each alarm code is complete of the status of the **RED** light indicator:  = **on**;  = **blinking**;  = **flashing with pulses**;  = **off**. Some alarms are signalled with a combination of two or more lights, in this case the light colours are explicitly reported close to the relevant status.

































Operations accompanied by the symbol  are always reserved to the Technician. Operations with grey background are reserved to the Technician.

Signal	Probable causes	Suggested solutions
01 	Boiler just installed (air mixed to gas).	Retry the ignition several times: turn the knob  on the unlock position  , wait the red light to turn off, then bring the knob in the previous position.
	The flame has extinguished or it did not ignite	Restore the boiler function by turning the knob  on the unlock position  , wait the red light to turn off, then bring the knob in the previous position.
	Incorrect combustion / flame detachment from the burner	<p>Check that the Inlet/Outlet Ducts and the respective terminals are clean and in good condition, and that there are no leaks in them. During the installation, respect the regulation prescriptions, the slopes and the lengths (see "Flue systems" on page 22).</p> <p><i>Note for the TECHNICIAN: The burner flame is not detected by the control electronics because it has not turned on or it has suddenly turned off, or it has detached from the burner, because of an incorrect combustion. This can be due, in example, to combustion product reflow into inlet duct, leaks in inlet/outlet ducts or errors in sizing of ducts (ducts length out of the allowed range, and/or wrong use of the reducer on boiler's outlet).</i></p>
	Incorrect electrical supply	<p>Check that the electrical connections Live, Neutral and Earth are correct and efficient, and especially that the Live and the Neutral are not swapped (see "Electrical diagram" on page 48).</p> <p><i>Remark: The problem may also be caused by an incorrect electricity supply by the Electrical Agency (unbalanced Neutral).</i></p>
	Condensate drain problem	<p>Verify and restore the correct condensate drain.</p> <p> Warning! DO NOT open the combustion assembly before having cleared the drain and removed the condense accumulated in the combustion chamber. <i>This alarm is caused by the condensate that, after having partially filled the combustion chamber, reaches the detection electrode and inhibits the detection of the flame ionisation.</i></p> <p>Then, check the combustion and verify that the burner is clean and in good conditions.</p>

Signal	Probable causes	Suggested solutions
02 	the boiler has overheated and the Safety Thermostat has triggered	Turn the knob  on the unlock  position until the red lamp turns off (or eventually for a longer period to make the boiler cool), then bring the knob in the previous position. If necessary, wait and try again for few times. If the lockout persists or reappears, call the Service Centre.  Verify the safety thermostat functionality. Detect the causes of the overheating, e.g. an insufficient circulation in the primary circuit; max gas pressure out of the limits or maximum heating power excessive for the heating system size.
03  	The overheat thermal fuse of the combustion assembly has triggered (combustion assembly overheating)	Solve the problem that caused the overheating, then replace the combustion assembly. <i>Note for the TECHNICIAN: the condensing combustion assembly has overheated and the relevant thermal fuse has blown. This is an extreme protection that normally is anticipated by other safety thermostats. If, in case of fault, those devices should not trigger and the burner should get hotter and hotter, the thermal fuse will cause the block of the boiler to avoid damages to building and furniture, but the combustion group must be considered damaged and therefore it must be replaced.</i>
	The flue overheat thermal fuse has triggered (flue on boiler outlet too hot)	Solve the problem that caused the overheating of the flue, then replace the flue thermal fuse. <i>Note for the TECHNICIAN: the flue thermal fuse preserves the flue ducts (that are made with Polypropylene, a material suitable to the condensate acidity) from the high temperatures, that could lead to their fusion or deformation. The triggering of this device consists in its blowing and therefore it must be replaced.</i>
- 5	Communication between display and main PCB is not correct	At every Power On, this alarm is showed for max 2-3 seconds; then it will disappear. If not, call the Service.  Check display, main PCB and connection wire. Replace what it is needed.
05  	Failure to the system flow temperature probe.	Check the cabling of the system flow temperature probe (primary circuit). Replacement of the system flow temperature probe.
10 	Insufficient system pressure (loss of water pressure switch triggered)	Restore the correct pressure as described in "Preliminary operations" on page 9 or (preferably by the Technician) in "Heating system filling and pressuring" on page 19. <i>Remark: Consider that the pressure, in normal conditions, should not decrease with the progress of the time. If this happens, there is probably a loss in the heating system. Sometimes the loss is so small that it doesn't leave evident signs, but with the progress of the time it can cause the decreasing of the pressure. Also the opening of the manual venting taps of radiators (intentional or unintentional) makes the pressure decrease. Check that this doesn't happen.</i>
12  	Failure to the DHW storage temperature probe.	Check the cabling of the DHW storage temperature probe. Replacement of the DHW storage temperature probe. <i>Remark: If no probe is present (storage unit not installed or storage temperature managed by thermostatic contact or solar system) check that, on the storage temperature sensor terminals STB, is installed a 2.2 kohm 1/2 W resistor (factory preset, see "Electrical diagram" on page 48).</i>
15  	Failure to the heating system return temperature probe.	Check the cabling of the system return temperature probe. Replacement of the system return temperature probe.

Signal	Probable causes	Suggested solutions
16  	Fan failure. The burner fan is stopped or rotates at an incorrect speed.	User: Restore the boiler function by turning the knob  on the unlock position  , wait the red light to turn off, then bring the knob in the previous position. Check the burner fan functionality. Replace it if necessary.
22  	Memory-stored data not coherent.	User: Disconnect the electrical supply to the boiler by operating the suitable external bipolar switch, then connect it again after a few minutes. If the lockout persists or reappears, call the Service Centre. Redo all the boiler settings ("Max heating power adjustment" on page 34 and "Electronic settings" on page 35) to update the data in the main board memory. Replace the main board (consequently, redo the "Max heating power adjustment" on page 34 and "Electronic settings" on page 35).
24 	Floor heating system safety thermostat triggering: system flow temperature too high; floor heating system defective, faulty or malfunctioning.	The floor heating system and the floor cladding can be damaged by temperature shocks, so a good quality system includes one or more safety thermostats that, if necessary, trigger and lock the boiler. Turn the knob  on the unlock  position until the red lamp turns off (or eventually for a longer period to cool the system and restore the thermostat), then bring the knob in the previous position. If the lockout persists or reappears, call the Service Centre <i>Remark: when this alarm is active, the hot water production is locked too.</i>
31  	Remote control* not working <i>Data exchanged between the boiler and the Remote Control don't comply with the expected protocol.</i> <i>* This applies to Remote Control optional kit only, and not to third parties chrono-thermostats</i>	User: see also paragraph "Remote Control Kit" on page 52. <i>Under these conditions, the boiler functions only in Sanitary. If the heating was necessary, and no spare Remote Control nor standard room thermostat were immediately available, ask the technician to temporarily make heating work manually from the boiler's control panel (excluding the operation from the remote control).</i>
Note for the TECHNICIAN: to activate the heating in manual mode, jumper the boiler's room thermostat input (see "Electrical diagram" on page 48); make the boiler operate in Winter mode by regulating the heating temperature manually from the boiler's control panel. Show the User how to adjust the heating from the boiler's in-built control panel, by rotating the Summer/Winter  knob within the scale  .		

Signal	Probable causes	Suggested solutions
33-34 	Cabling configuration error.	Refer to the electric diagram (page 48) and check the integrity of the wirings, especially the eventual short cable jumpers between two contacts of the same connector (on the cabling connections to the electronic board).
35 RED  YELLOW 	Unexpected flame the control electronic has detected the flame on the burner when this one should be off	<p>Wait for the boiler automatic reset (5 minutes) or reset it manually by turning the knob  on the unlock position  , waiting the red light to turn off, then bringing the knob in the previous position. If the lockout persists or reappears, call the Service Centre</p> <p> Detect eventual malfunctioning of the gas valve (that does not stop fully the gas flow, so the burner remains ignited) or of the electronics, flame detection section (that detects the flame presence even if it's absent).</p>
38 	<p>Failure to the outdoor temperature probe (optional).</p> <p>The outdoor temperature probe, that was recognized and working, now results faulty.</p>	<p>User: Call the Service Centre.</p> <p><i>The boiler now works either in heating and in hot water, like as the external boiler had never been installed, so the heating system temperature is set by the knob  , in direct way and not as a function of the outdoor temperature. The alarm is displayed to inform that the accessory is no more efficient (consider that, on a first analysis, the boiler seems to work perfectly). Important: if the boiler is turned off and then on again, it's possible** that the alarm is no more displayed, even though the problem persists.</i></p> <p>Check the cabling of the outdoor temperature probe.</p> <p>Replacement of the outdoor temperature probe.</p> <p><i>** The alarm shows again only if the resistance of the probe is out of tolerance or in short-circuit. On the contrary, if the probe or the relevant cabling is interrupted, when the electrical supply is restored the boiler will consider the external probe absent and, in Winter mode, it will work in normal mode (temperature shifting disabled).</i></p>
39 	<p>Suspected freezing</p> <p>After a power failure, the boiler detected temperatures at the Heating and DHW probes equal to, or less than, 0°C when power was restored</p>	<p>The display shows the alarm code 39 while the boiler inhibits the ignition of the burner and activates the circulator, forcing water to circulate in the hydraulic circuits.</p> <p>If, during this time, the temperatures measured by the probes rise above +1°C, the alarm is reset and the boiler returns to the normal operation.</p> <p>Otherwise, the alarm will persist and you should suspect that water has frozen at one or more points of the hydraulic circuit of the boiler and/or system (with possible damage to the frozen parts). If the alarm persists, call a qualified technician.</p> <p> Find/replace the parts damaged by the freezing.</p>
42  RED  YELLOW 	<p>System error</p> <p>Anomaly of inner boiler device(s)</p> <p>Mains electrical power supply out of tolerance limits</p>	Detect the fault or anomaly also referring to the technical literature reserved to the service centres.

Signal	Probable causes	Suggested solutions
43 	Over-temperature of water on system return	<p>The water that returns to the boiler from the heating system is too hot: this may be an effect of a malfunction of the system, and anyway this can cause a too high temperature of the flue and damage the flue system. Before this happens, a suitable safety protection has triggered.</p> <p>Wait 20-30 minutes to let the boiler and the system cool down, then turn the knob  on the unlock  position until the red lamp turns off, then bring again the knob in the previous position. It is impossible to restart the boiler before the cooling of the system. If the block happens again, please call a qualified technician.</p>
46 	Cabling configuration error.	See alarm 33 .
-- (??) 	The "Hot Water" knob  is on a position reserved to the technician:  or service .	Turn the knob back along the scale  .
-- (??) RED  GREEN 	it has been started, by mistake (moreover very improbable), a procedure reserved to the Technician	In order to avoid malfunctions, do the following as soon as possible: <ul style="list-style-type: none"> ▶ turn the knob  on the off/unlock  position; ▶ turn the "Hot Water" knob  along the scale  ; ▶ turn the knob  on the normal working position (Summer  or Winter  along the scale ).

Warnings for servicing



All servicing operations and gas conversions **MUST BE CARRIED OUT BY QUALIFIED TECHNICIANS**, in compliance with the norms and laws in force (see an indicative list on page 4). Moreover, **MAINTENANCE** operations must be carried out in compliance with the manufacturer prescriptions and with the laws and rules presently in force, for the parts not mentioned in this handbook; we advise to perform them at least once a year to maintain the boiler's performance.

A careful servicing is always a guarantee of safety and energy saving. Normally, it will be necessary to execute the following operations:

- ▶ Remove any possible oxidization from burners and electrodes;
- ▶ Remove the scale from the exchangers;
- ▶ Cleaning and checking the exchanger, the siphon and all the parts which are in touch with the condense;
- ▶ Check integrity and stability of the insulating coverings in the combustion chamber and proceed eventually to substitution;
- ▶ Check and eventual substitution of the magnesium anode of the storage unit (see the documentation supplied with the unit);
- ▶ Check the boiler ignition, switching off and operation;
- ▶ Check the water and gas connections tightness;
- ▶ Check the gas consumption at the minimum and maximum output;
- ▶ Verify that safety devices are correctly working;
- ▶ Verify the correct functioning of control and adjusting devices;
- ▶ Verify periodically the absence of leaks of combustion products to the inner room, the correct functioning and the integrity of the flue outlet ducts and/or devices and of the relevant terminals and accessories;
- ▶ In case of works or servicing of the structures placed near the above mentioned ducts and /or devices and their accessories, switch off the boiler;
- ▶ Do not leave any inflammable tanks and/or substances in the installation room;
- ▶ If the boiler draws directly from the installation room (*type B appliance installed indoor*): Do not clean the room where boiler is installed, while it is working
- ▶ Clean casing with soapy water only. Do not clean casing, other painted or plastic surfaces with thinner.
- ▶ In any case of parts replacement, it is mandatory to use ITALTHERM original spare parts.

ITALTHERM declines any responsibility in case of non-original spare parts utilization.

"Once all check and servicing operations have been carried out, the technician must write a report for the user, who must countersign a copy for receipt and vision" as prescribed by the regulation in force.

Technical data

TECHNICAL DATA	U.M.	City Plus 26 KR	
		G20	G31

CE certification		0694 CM 3400	
Class		II ₂ H ₃ P	
Type		B23 - B23P - C13 - C33 - C43 - C53 - C63 - C83 - C93	
Working temperature range (min÷max)	°C	0 ÷ +60	

Max heat input	kW	26.2	26.2
Min heat input	kW	5.3	5.3
Max heat output 60°/80°C *	kW	25.4	25.4
Min heat output 60°/80°C *	kW	5.1	5.1
Max heat output 30°/50°C *	kW	27.5	27.5
Min heat output 30°/50°C *	kW	5.5	5.5
NO _x Class		5	5
CO at 0% O ₂ (Qn)	ppm	129.7	143.7
CO ₂ at nominal input	%	9.2	10.2
Condense quantity at Qn (30°/50°C *)	l/h	2.3	1.5
Condense quantity at Qr (30°/50°C *)	l/h	0.5	0.4
Condense acidity	pH	2.8	2.8
Flue temperature (Qn)	°C	76.5	76.5
Flue mass flow rate (60/80°C - Qn)	kg/h	42.61	43.49

EFFICIENCY

Nominal efficiency at 60°/80°C *	%	96.9
Efficiency at 30% load at 60°/80°C *	%	100.4
Nominal efficiency at 30°/50°C *	%	105.1
Efficiency at 30% load at 30°/50°C *	%	107.2

* system return / flow water temperature

Remark: data have been measured with horizontal coaxial flue, length = 1 m.

HEATING

Temperature selection range (min÷max) <i>Main heating circuit, normal range / low temp. range</i>	°C	35÷78 / 20÷45
Temperature selection range (min÷max) <i>Secondary heating circuit</i>	°C	20÷78
Characteristics of the heating system water (or filling liquid) <i>(* = if aluminium parts are present along the system)</i>	°f pH	5 ÷ 15 °f pH 7.5 ÷ 9.5 (7.5 ÷ 8.5 *)
Expansion vessel	l	8
Expansion vessel pre-loading pressure	bar	1

(continua)

TECHNICAL DATA (cont'd)	U.M.	City Plus 26 KR	
		G20	G31
		0.5 / 0.9 (±0.2)	
Loss of water pressure switch off / on pressure	bar	<i>To allow the correct system filling, the pressure of the domestic water should be higher than the ON value of the pressure switch.</i>	
Max system temperature	°C	83	
Anti-freezing function temperature on / off	°C	5 / 30	

HOT WATER

Max supply pressure	bar	6
Remote storage tank temperature selection range (min÷max)	°C	30÷60

ELECTRICAL DATA

Voltage / frequency (nominal voltage)	V / Hz	220÷240 / 50 (230V)
Power consumption	W	165
Level of protection		IP X4D

DIMENSIONS

Width - Height - Depth	mm	see "Dimensions and connections" on page 14
Weight	kg	34.6

CONNECTIONS

Hydraulic and gas connections		see "Dimensions and connections" on page 14
Flue: types, lengths and diameters		see "Flue systems" on page 22
Fan head loss	Pa	40 ÷ 150

GAS SUPPLY PRESSURE

Nominal pressure	mbar	20	37
Inlet pressure (min÷max)	mbar	17 ÷ 25	35÷40
Gas valve diaphragm diameter	mm	5.5	4.0
Colour of the calibrated plug for sealed chamber compensation		Grey "Silver"	Yellow "Brass"

GAS CONSUMPTION

Qmax	m³/h	2.77	
	kg/h		2.03
Qmin	m³/h	0.56	
	kg/h		0.41

Boiler internal components

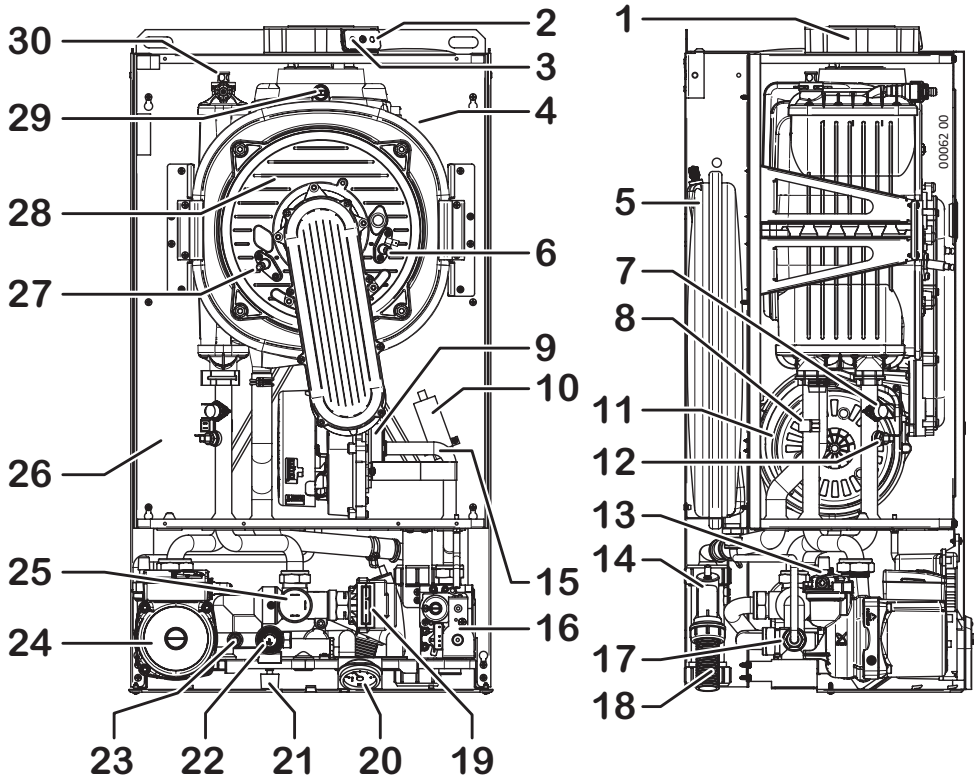

- | | | | |
|----|--|----|--|
| 1 | Flue connection flange | 17 | By-Pass |
| 2 | Plug for Combustion analysis (air inlet) | 18 | Pipe for condensate outlet |
| 3 | Plug for Combustion analysis (flue) | 19 | Motorized 3-way valve |
| 4 | Combustion assembly overheat fuse (connector) | 20 | System pressure gauge |
| 5 | Expansion Vessel | 21 | Filling valve |
| 6 | Ignition Electrode | 22 | Safety valve 3 bar |
| 7 | Safety thermostat on system flow | 23 | Drain valve |
| 8 | Temperature Sensor on system return | 24 | Pump |
| 9 | Air/Gas Mixing System | 25 | Loss of water pressure switch |
| 10 | Electronic igniter | 26 | Sealed Chamber |
| 11 | Fan | 27 | Flame detection electrode |
| 12 | Temperature Sensor, system flow | 28 | Combustion assembly (burner+primary exchanger) |
| 13 | Automatic Venting Device (heating circuit, incorporated in the pump) | 29 | Flue overheat fuse |
| 14 | Siphon for condensate outlet | 30 | Manual Venting Device (Combustion assembly) |
| 15 | Gas injection pipe | | |
| 16 | Gas valve | | |

Remark: Depending on the model, the position and the shape of some items could slightly differ from the drawing.

- 4 Combustion assembly overheat fuse (*)
- 6 Ignition Electrode
- 7 Safety thermostat on system flow (*)
- 8 Temperature Sensor on system return
- 10 Electronic igniter
- 11.1 Fan - speed control
- 11.2 Fan - supply
- 12 Temperature Sensor, system flow
- 16 Gas valve
- 19 Motorized 3-way valve
- 24 Pump
- 25 Loss of water pressure switch (*)
- 27 Flame detection electrode
- 29 Flue overheat fuse
- 60 Display board
- 61 Fuse F2A (2A fast)
- 62 Resistor, 2.2 kOhm - 1/2W (**)

Optional external devices:

- TA2 To optional room thermostat for zones with different temperature range
- TB DHW Storage thermostat (*) (**)
- STB DHW Storage temperature sensor (**)

70 Room thermostat: Voltage-free Contact for Room Thermostat or Chronothermostat (for trade) working at safety extra low voltage SELV. Closed contact = heating request.

Remote control: Terminals of the original remote control device. See also page 52.
To install, open the junction on the wires and connect them to the device terminals (eventually, extend the cable)

- 71 Connector for CH multi zones PCB kit
- 72 To optional floor heating system safety thermostat
- 73 To optional outdoor temperature sensor

(*) the contacts of these components are shown in rest conditions (cold condition, no system pressure, no flow)
(**) see "Electrical connection between the boiler and the storage unit" on page 22 for details.

Abbreviations:

- BK Black
- BN Brown
- BU Blue
- GN Green
- GY Grey
- OG Orange
- RD Red

- VT Violet
- WH White
- YE Yellow

- COM Common
- DHW DHW mode
- NC Normally Closed
- NO Normally Open
- HEA Heating mode

Hydraulic diagram



This diagram is for information only. To make boiler hydraulic connection either see "Dimensions and connections" on page 14 and eventually "Positioning and fastening" on page 16.

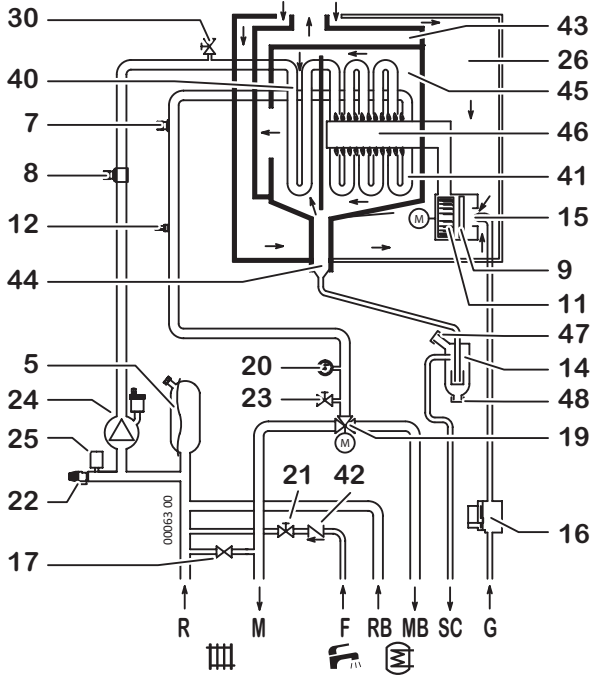

- | | | | |
|----|---|----|--|
| 5 | Expansion Vessel | 40 | Primary exchanger (condensing section) |
| 7 | Safety thermostat on system flow | 41 | Primary exchanger (combustion section) |
| 8 | Temperature Sensor on system return | 42 | Check valve |
| 9 | Air/Gas Mixing System | 43 | Flue hood |
| 11 | Fan | 44 | Condense drain in combustion assembly |
| 12 | Temperature Sensor, system flow | 45 | Combustion chamber |
| 14 | Siphon for condense outlet | 46 | Burner |
| 15 | Gas injection pipe | 47 | Overflow drain of condensate trap |
| 16 | Gas valve | 48 | Tap for condensate trap cleaning |
| 17 | By-Pass | | |
| 19 | Motorized 3-way valve | | |
| 20 | System pressure gauge | | |
| 21 | Filling valve | | |
| 22 | Safety valve 3 bar | | |
| 23 | Drain valve | | |
| 24 | Pump | | |
| 25 | Loss of water pressure switch | | |
| 26 | Sealed Chamber | | |
| 30 | Manual Venting Device (Combustion assembly) | | |
| | | R | Heating return |
| | | M | Heating flow |
| | | F | Cold water inlet |
| | | RB | Return from storage coil |
| | | MB | Flow to storage coil |
| | | SC | Condensate drain |
| | | G | Gas inlet |

Outdoor Sensor Kit

Installation and setting

The Outdoor Sensor manages automatically the CH flow temperature** as a function of the outdoor temperature, thus avoiding the user to adjust it manually. This function is also named "shifting temperature".

** that's the temperature of the heating elements. Don't mistake it with the room temperature (managed by the room thermostat or by the Remote Control, but not by the boiler) that doesn't depend on the first one.

The installation must be made by a professionally skilled technician following the instructions supplied with the kit. Refer to "Electrical diagram" on page 48 for the links to the Main Board.

After the installation of the Sensor, **the Summer/Winter knob won't adjust directly the CH flow temperature, but the dispersion factor "kd" that's the response of the outdoor temperature, detected by the sensor, on the CH flow temperature (see graph).**

Practically, kd value should be adjusted depending on the estimated efficiency of the building's thermal insulation. Its range is from 01 to 30: use higher values when there is a high thermal dispersion and therefore a less efficient insulation (and vice versa).

(i) Because of the wide buildings typologies, it's impossible to give precise indications on kd value to set. **The correct setting must be determined case by case and will have, as a result, an optimal comfort in all the climatic conditions** requiring heating, i.e. a prompt reaching of the room temperature with cold weather and no room overheating during mild periods.

Outdoor Sensor kit and Remote Control

If also the Remote Control Kit is installed, its parameter **P04** (modulation mode) should be set on value **2** (modulating on outdoor sensor and on-off on room sensor) or **3** (modulating on both outdoor and room sensors) as described in the **paragraph 5** of the instruction booklet included in the Remote Control Kit. Afterwards, also the **kd** should be set on this latter (refer to **paragraph 8.6** of the same booklet). On the Remote Control, just because of different display, the **kd** adjustment range is **0.1...3.0** instead of 01...30.

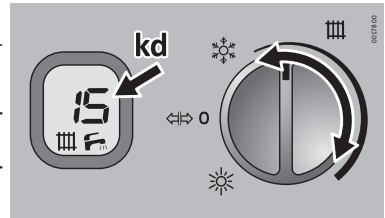
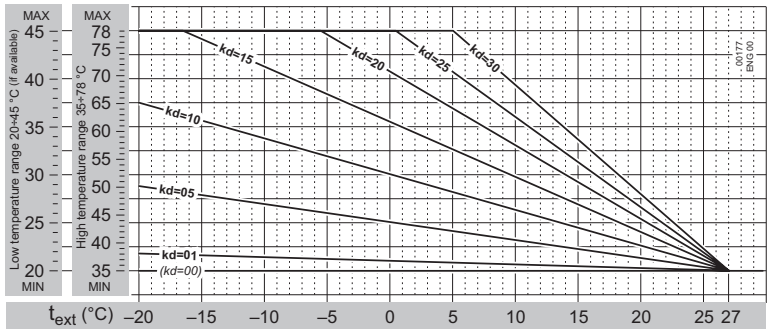

Remote Control Kit

This remote control is **more than a simple room thermostat**. Thanks to this, it is possible to **manage the boiler in all its settings** like DHW and CH temperature adjustment, **boiler reset** in case of boiler block, and of course it works as a **room thermostat** both in **manual** and **weekly program** mode. It's powered by the boiler (in safety low voltage), so **it doesn't need batteries**.



(i) Extract the Remote Control from its package. **Keep the relevant user instruction booklet and annex it to this Manual.**

⚡ **Nor the Remote Control neither the relevant cable coming from the boiler must not, for any reason, be connected to the 230Vac supply mains.**



(i) To avoid malfunctions due to electrical noise, the Remote Control connections, as well as all low-voltage connections, should be kept separated from power supply cables, e.g. by enclosing it into separate raceways.





The maximum overall cable length shouldn't exceed 50 m.

1. Cut off electricity from boiler;
2. install the device as described in the **paragraph 4** of the supplied instruction booklet;
3. link the Remote Control wirings to the "Room Thermostat - Remote Control" cable coming out of the boiler, by means of a suitable bipolar terminal. See also "Electrical diagram" on page 48;

Note: *The Remote Control link is not polarized.*

4. power supply the boiler; **turn the boiler's Summer/Winter knob  on Summer  otherwise the Remote Control doesn't work** and the boiler goes into alarm **31** described below;
5. check the correct work of the device. The electronics should recognize it automatically.

(i) Hereafter, the Summer/Winter knob  should be left on Summer ; the boiler work is managed by the Remote Control, including the OFF, Summer and Winter modes, and the technical functions (such as several additional functions).

Signal	Probable causes	Suggested solutions
31	Communication error between the Remote Control (if present) and the boiler	<p>Disconnect the electrical supply to the boiler for 30 seconds by operating the suitable external bipolar switch, turn the boiler's Summer/Winter knob on Summer , then power supply the boiler.</p> <p>If the lockout persists or reappears, call the Service Centre. Under these conditions, the boiler works only in DHW.</p>
<p>🔧 For the Technician: Problems on the optional Remote Control connection link (passing close to supply cables or other electromagnetic field sources; connection failure; cable length over 50 meters).</p>		



www.italtherm.it

ITALTHERM Srl

Via S. D'Acquisto, snc • 29010 Pontenure (PC) - IT
Tel. +39.0523.575611 • Fax +39.0523.575600

www.italtherm.it • e-mail: info@italtherm.it



960000006_05_ENG - 09/03/2015

ITALTHERM Srl declines any responsibility for eventual printing and/or transcription errors in the present manual. In order to constantly improve its products, the company has the right to change features and data written in the present manual, at any time and without notice.