

# BAXI

## SOLO HE A

Compact heat only boiler



# The brand that stands for quality and innovation

There's much more to Baxi than our great range of boilers.

We've been producing boilers for over 150 years, that's before the first motor car or the first electric light were built. We've earned an unparalleled reputation over the years because we are always striving to create highly efficient, cost effective and reliable heating and hot water solutions for every installation, it's what we do best.

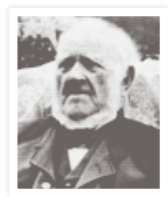

**1866**

The company is founded by Richard Baxendale in Chorley, Lancashire



**1966**

The original Baxi Bermuda back boiler revolutionises home heating and hot water



**2001**

The Baxi 105 E becomes the biggest selling combination boiler in the UK



**2006**

The Baxi Duo-tec HE is launched and is awarded the UK's 2007 'Best Buy' by Which? and wins 2008 CORGI Boiler of the Year



**2010**

The Baxi Ecogen becomes the UK's first domestic micro-CHP unit, winning multiple awards

We're very proud of our long heritage of quality and innovation, and that we continue to manufacture here in the UK. All Baxi Solo HE A boilers are Energy Saving Trust Recommended products to give your customers added peace of mind.

Made in the UK



# Baxi Solo HE A

The simple contemporary lines and soft curves are bound to appeal to customers, as will the beautifully simple controls that make it easy to use. Its clean, compact, space saving design means that it can be fitted discreetly into a kitchen cupboard\*, offering more flexible siting.

It may be small in size, but it's big in performance, and with an extended range of models now available, it is the perfect heat only choice for any size property.



\* Standard cupboard dimensions of 900mm x 500mm x 300mm

## Key features & benefits:

- Available in five outputs 12kW, 15kW, 18kW, 24kW and 30kW, this modulating boiler fits most size systems ✓
- Lightweight, compact, cupboard fit\* design for flexible siting ✓
- Can be installed on a fully TRV system ✓
- Suitable for use with open vented or sealed heating systems ✓
- Simple controls for easy operation ✓
- No pump overrun required, meaning this boiler will directly replace any existing heat only boiler ✓
- Energy Saving Trust Recommended ✓
- Two year parts and labour warranty giving customers complete peace of mind through our award-winning customer service division heateam ✓



# Technical specifications

Baxi Solo HE A Series Wall mounted high efficiency boilers		12kW	15kW	18kW	24kW	30kW
<b>CONTROLS</b>						
Concealed User Controls		Yes	Yes	Yes	Yes	Yes
User Adjustable CH Temperature		Yes	Yes	Yes	Yes	Yes
LED Status/Fault Diagnosis Display		Yes	Yes	Yes	Yes	Yes
<b>GAS</b>						
Gas Supply Pipe Size	mm	15	15	15	15	15
Natural Gas		Yes	Yes	Yes	Yes	Yes
LPG (Butane/Propane)		No	No	No	No	No
Nominal Inlet Supply Pressure	mbar	20	20	20	20	20
Maximum Gas Rate	m <sup>3</sup> /hr	1.34	1.64	1.94	2.31	2.95
Heat Input Central Heating	kW Max Gross	13.3	16.9	20.2	24.5	33.8
	kW Max Net	12.0	15.2	18.2	22.1	30.4
Heat Output CH Non Condensing	kW Max	11.8	15.2	17.8	22	30.2
Heat Output CH Condensing	kW Max	12.8	16.5	19.3	23.8	32.6
SEDBUK 2005 Seasonal Efficiency NG / LPG	%	90.5	91.3	90.4	90.9	90.9
SEDBUK 2009 Seasonal Efficiency NG / LPG	%	88.7	89.4	88.7	88.8	88.8
NO <sub>x</sub> Class		5	5	5	5	5
NO <sub>x</sub> Levels	mg/kWh	13.1	29.0	11.7	37.0	48.0
<b>ELECTRICAL</b>						
Electrical Supply	Volts/Hz	230V/50Hz	230V/50Hz	230V/50Hz	230V/50Hz	230V/50Hz
Permanent Live Required		No	No	No	No	No
Electrical Cable Required		3 core x 0.75mm <sup>2</sup>				
Power Consumption	Watts	80	80	80	80	80
External Fuse Rating	Amps	3	3	3	3	3
Internal Fuse Rating	Amps	3.15	3.15	3.15	3.15	3.15
Ingress Protection Rating (without electro-mechanical timer fitted)		IPX2	IPX2	IPX2	IPX2	IPX2
Integral 'Boiler Only' Frost Thermostat		No	No	No	No	No
Pump Overrun		No	No	No	No	No
<b>MECHANICAL &amp; HYDRAULIC</b>						
Compartment Ventilation Required		None	None	None	None	None
Flow & Return Pipe Size	mm	22	22	22	22	22
Condensate Discharge Pipe Connection	mm	21.5	21.5	21.5	21.5	21.5
Bypass Required		No	No	No	No	No
Vertical Pipe Route		Within Case				
CH System Inhibitor Required		Yes	Yes	Yes	Yes	Yes
<b>CONCENTRIC FLUE SYSTEM</b>						
Outside Diameter	mm	110	110	110	110	110
Standard Horizontal Flue Kit Length	mm	850	850	850	850	850
Max Equivalent Length Horizontal	m	4 plus Terminal				
Max Equivalent Length Vertical	m	4 plus Terminal				
Equivalent Length per 135° Bend	m	0.5	0.5	0.5	0.5	0.5
Equivalent Length per 93° Bend	m	1	1	1	1	1
<b>TWIN PIPE FLUE SYSTEM</b>						
Diameters	mm	80/80	80/80	80/80	80/80	80/80
Max Equivalent Length Horizontal (parallel pipes)	m	75	75	75	75	75
Max Equivalent Length Vertical (parallel pipes)	m	75	75	75	75	75
Equivalent Length per 135° Bend	m	1.3 Air & 2.6 Flue				
Equivalent Length per 90° Bend	m	4.8 Air & 9.6 Flue				
<b>WEIGHTS</b>						
Max Installer Lift Weight	kg	26	26	26	26	26
Gross Packaged Boiler Weight	kg	36.2	36.2	36.2	36.2	36.2

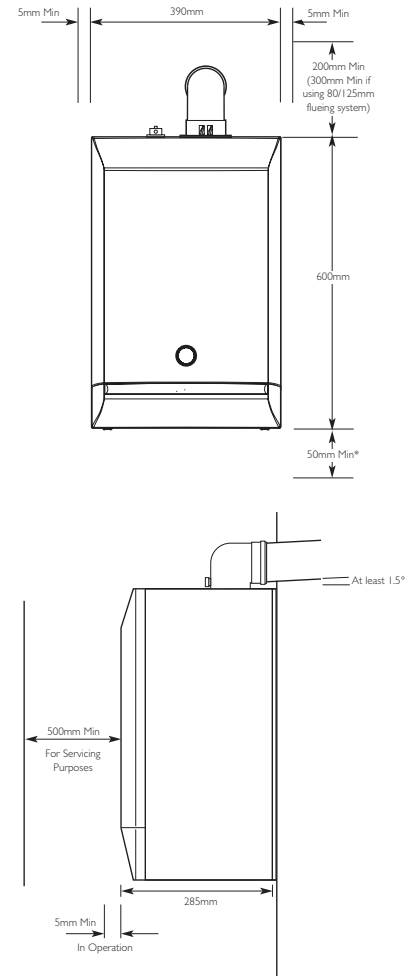

# Flue options

1. Baxi Boilers can be fitted with flue systems as illustrated.
2. The standard flue is suitable only for horizontal termination applications.
3. Maximum permissible equivalent flue lengths for Solo HE A are:



Horizontal Concentric	4 metres
Vertical Concentric	4 metres
Horizontal Twin pipe	75 metres (parallel pipes)
Vertical Twin pipe	75 metres (parallel pipes)

4. The elbow supplied with the standard horizontal flue kit is not included in any equivalent length reductions.

Twin Flue Pipe	135° bend (air duct)	1.3 m
	135° bend (flue duct)	2.6 m
	91.5° bend (air duct)	4.8 m
	91.5° bend (flue duct)	9.6 m

5. Any further "in line" bends in the flue system must be taken into consideration.
6. The illustrations show examples of permissible flue systems.
7. Instructions for guidance and fitting are included in each kit, where appropriate.







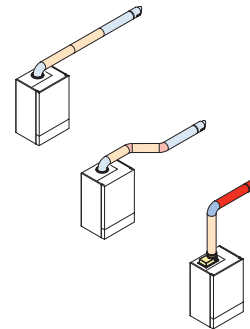

## GROUP B Concentric Horizontal Flue System 70/110mm diameter for use with Solo HE A

Key	Item Description	Specification	OD Dimensions	Multifit Sales Code
	Standard Horizontal Flue inc Elbow	850mm	110mm	236921
	Horizontal Flue/Wall Terminal	850mm	110mm	243013BAX
	Vertical Flue Adaptor (Boiler)		110mm	5106888
	Flue Extension	1000mm	110mm	241695
	Flue Extension	500mm	110mm	241694
	Flue Extension	250m	110mm	241692
	Flue Bend	93 degree	110mm	241687
	Flue Bend (Pair)	135 degree	110mm	241689
Not illustrated	Pipe Support		110mm	243014BAX
Not illustrated	Flue Terminal Deflector			248167

NOTE: The 3 degree fall back on concentric flues can be reduced to 1.5 degrees providing the flue system is adequately clamped in accordance with the installation instructions.





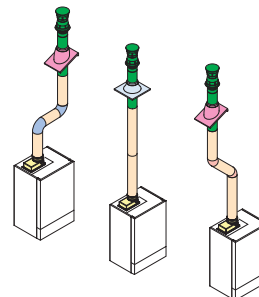

## GROUP B Concentric Vertical Flue System 70/110mm diameter for use with Solo HE A

Key	Item Description	Specification	OD Dimensions	Multifit Sales Code
	Vertical Roof Terminal		70/110mm	242802
	Vertical Flue Adaptor (Boiler)		110mm	5106888
	Flue Extension	1000mm	110mm	241695
	Flue Extension	500mm	110mm	241694
	Flue Extension	250m	110mm	241692
	Flue Bend	93 degree	110mm	241687
	Flue Bend (Pair)	135 degree	110mm	241689
Not illustrated	Pipe Support		110mm	243014BAX
	Pitched Roof Flashing	25/50 degree	125mm	243015
	Flat Roof Flashing		125mm	243016BAX
Not illustrated	Roof Cover Plate			243131







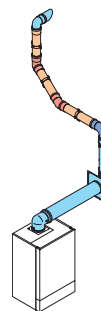



## GROUP L Plume Displacement Kits 70/110mm diameter for use with Solo HE A

Key	Item Description	Specification	OD Dimensions	Multifit Sales Code
	Plume Displacement Kit inc Elbow & Clips		110mm	5121371
	Plume Displacement Kit Extension & Clip	1000mm	70mm	5121372
	Plume Displacement Kit Bend	93 degree	70mm	5121373
	Plume Displacement Kit Bend (Pair)	135 degree	70mm	5121374



## GROUP P Twin Flue System 80/80mm diameter for use with Solo HE A

Key	Item Description	Specification	OD Dimensions	Multifit Sales Code
	Vertical Roof Terminal		70/110mm	242802
	Horizontal/Wall Terminal	850mm	110mm	243013BAX
	Twin Pipe Flue Adaptor Set			242757
	Twin Pipe Flue Extension	250mm	80mm	246135
	Twin Pipe Flue Extension	500mm	80mm	246136
	Twin Pipe Flue Extension	1000m	80mm	246137
	Twin Pipe Flue Bend (Pair)	90 degree	80mm	5121560
Not illustrated	Twin Pipe Flue Bend (Pair)	135 degree	80mm	5121561
Not illustrated	Pipe Support		110mm	243014BAX
Not illustrated	Twin Pipe Support (Pair)		80mm	5111081
	Pitched Roof Flashing	25/50 degree	125mm	243015
Not illustrated	Flat Roof Flashing			243016BAX
Not illustrated	Flue Terminal Deflector			248167
Not illustrated	Roof Cover Plate			243131

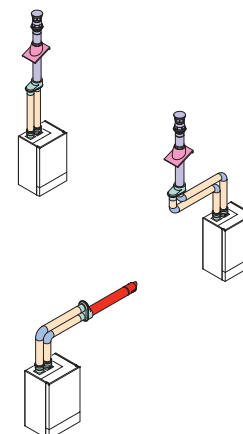

# Supporting the best, with the best



Call us on **0844 871 1525**  
[www.heateam.co.uk](http://www.heateam.co.uk)

heateam opening hours are:  
Monday - Friday 8am - 6pm  
Saturday/Sunday 8.30am - 2pm

Our aftersales support is on hand whenever you need it, even if you haven't finished the installation yet

## Technical support

If you need additional information to complete an installation while on site, our technical support team made up of experienced **heateam** gas engineers are always available on the end of the phone with direct access to our boilers to provide all the backup you need to get the job finished quickly and easily.

## Warranties

Once you've installed your customer's new Baxi boiler they will be covered by our two years parts and labour warranty\*. They can register their warranty either online or by post, giving them complete peace of mind. Once this initial warranty has expired, they have the option of extending it.

\*Subject to registration and an annual service by any Gas Safe registered installer  
\*\*Calls booked before 3pm

## Aftersales service



**heateam**, our award-winning customer service division, is our team of 270 Gas Safe registered engineers working across the UK to ensure your customers are happy with their investment in their Baxi boiler. In fact, it's like having your very own aftersales team. Any problems encountered with a Baxi product within two years of installation will be resolved quickly and efficiently by one of our engineers.

If you're a member of our business support scheme **works** we will guarantee to be with your customer the very next day\*\*.

## Training

Baxi offers a range of boiler training courses for installers to help keep you informed of the latest industry developments and provide you with the relevant product knowledge and skills to ensure best practice. Visit [www.bdrthermeatraining.co.uk](http://www.bdrthermeatraining.co.uk) to find out more.



# BAXI

# works - you've earned it



We want to thank you for your business and help you grow it

Running a business of any size isn't easy, especially in the current economic climate. That's why we've set up **works**, our great new business support scheme. Far more than a loyalty programme, **works** rewards genuine two-way communication between you and Baxi.

Here are just a few of the benefits that **works** can offer:

### Rewards

Earn Business Points to spend on a range of gifts and business support



### Free Gas Safe notification

Save time and money on Gas Safe notifications with **works** easy online process



### Next day call out

We'll support you with next day call out\* from **heateam**, our award-winning customer service division



### Annual service reminder

We prompt your customers to call you when their annual service is due\*\*



### 'Find an installer'

We'll help you grow your business by adding a listing on to 'Find an installer' on the Baxi website



\* Calls booked before 3pm

\*\*Available for registered boilers only. See website for details

[www.works2gether.co.uk](http://www.works2gether.co.uk)

## Other heating solutions from Baxi

Regardless of property size or the number of occupants Baxi's wide range of Combi, System, Heat only and Back boilers can provide the perfect heating solution for your customers.



Baxi Duo-tec Combi GA

Our new range of GA boilers are easy to fit because they have many common features and components, aid you in the commissioning process and configure automatically to natural gas or LPG.

They also include compact, cupboard-fit\* models. These features can help you finish the installation faster and move on to the next one. Baxi's reliability also saves you hassle and protects your reputation.

\* Standard cupboard dimensions of 900mm x 500mm x 300mm with removal of control panel flap



## Contact us

For all enquiries, please call

0844 871 1525

Email: [info@baxi.co.uk](mailto:info@baxi.co.uk)

Visit: [www.baxi.co.uk](http://www.baxi.co.uk)

Open Monday - Friday, 8am - 6pm  
Saturdays & Bank Holidays, 8.30am - 2pm  
We are closed on Christmas Day & New Year's Day

To book a training course please call 0845 600 7402  
Open Monday - Thursday, 8.30am - 5pm  
Friday, 8.30am - 4.30pm  
or visit [www.bdrthermeatraining.co.uk](http://www.bdrthermeatraining.co.uk)

Please note calls may be monitored or recorded

## PART OF BDR THERMEA

Baxi, Brooks House, Coventry Road, Warwick CV34 4LL

[www.baxi.co.uk](http://www.baxi.co.uk)



This Brochure is printed on paper sourced from well managed forests, controlled sources. This Brochure is printed using vegetable based inks. Please recycle this Brochure when you have finished with it.

Baxi policy is one of continual improvement and development. The right to change specification and appearance without prior notice is reserved. The reproduction of colours is as accurate as photographic and printing processes allow. The consumer's statutory rights are not affected. e&oe