

User Guide

Gas Fired Wall Mounted Condensing Combination Boiler

EcoBlue Plus Combi

24 - 28 - 33

Please keep these instructions in a safe place.
If you move house, please hand them over to the next occupier.

Model Range

Baxi EcoBlue Plus 24 Combi ErP

G.C.N° 47-077-08

Baxi EcoBlue Plus 28 Combi ErP

G.C.N° 47-077-09

Baxi EcoBlue Plus 33 Combi ErP

G.C.N° 47-077-10

Dear Customer,

Thank you for purchasing this appliance.

Please read this manual carefully before using the product and keep it in a safe place for future reference.

In order to ensure continued safe and efficient operation we recommend that the product is regularly maintained. Our Service and After Sales organization can assist with this.

We hope you will receive many years of satisfactory service.



© Baxi Heating UK Ltd 2016 All rights reserved. No part of this publication may be reproduced or transmitted in any form or by any means, or stored in any retrieval system of any nature (including in any database), in each case whether electronic, mechanical, recording or otherwise, without the prior written permission of the copyright owner, except for permitted fair dealing under Copyrights, Designs and Patents Act 1988.



ISO 9001
FM 00866



Applications for the copyright owner's permission to reproduce or make other use of any part of this publication should be made, giving details of the proposed use, to the following address:

The Company Secretary, Baxi Heating UK Limited,
Brooks House, Coventry Road, Warwick. CV34 4LL

Full acknowledgement of author and source must be given.

WARNING: Any person who does any unauthorised act in relation to a copyright work may be liable to criminal prosecution and civil claims for damages.



The Benchmark Scheme

Baxi Heating UK Ltd is a licensed member of the Benchmark Scheme which aims to improve the standards of installation and commissioning of domestic heating and hot water systems in the UK and to encourage regular servicing to optimise safety, efficiency and performance.

Benchmark is managed and promoted by Heating and Hotwater Industry Council. For more information visit www.centralheating.co.uk

Contents

| | | |
|----------|---|-----------|
| 1 | Introduction | 5 |
| 1.1 | General | 5 |
| 1.2 | Additional Documentation | 5 |
| 1.3 | Symbols Used | 5 |
| 1.4 | Abbreviations / Glossary | 6 |
| 1.5 | Extent of Liabilities | 6 |
| 1.5.1 | Manufacturer's Liability | 6 |
| 1.5.2 | Installer's Responsibility | 7 |
| 1.5.3 | User's Responsibility | 7 |
| 2 | Safety | 8 |
| 2.1 | General Safety Instructions | 8 |
| 2.2 | Recommendations | 9 |
| 2.2.1 | Benchmark Commissioning Checklist | 9 |
| 3 | Technical Specifications | 10 |
| 3.1 | Technical Data | 10 |
| 4 | Description of the Product | 11 |
| 4.1 | General Description | 11 |
| 4.2 | Operating Principle | 11 |
| 4.2.1 | In Operation | 11 |
| 4.3 | Control Panel Description | 12 |
| 4.4 | Standard Delivery | 13 |
| 4.5 | Accessories & Options | 13 |
| 4.5.1 | Optional Extras | 13 |
| 5 | Operation | 14 |
| 5.1 | Operation Checking Procedure & Basic Fault Identification | 14 |
| 5.2 | Shutdown | 16 |
| 5.3 | Frost Protection | 16 |
| 6 | Settings | 17 |
| 6.1 | Setting the Boiler Temperatures | 17 |
| 6.1.1 | Boiler Temperature | 17 |
| 6.1.2 | Domestic Hot Water Temperature | 17 |
| 6.1.3 | Summer - Winter - Heating Only Mode | 17 |
| 6.1.4 | Information Display | 17 |
| 7 | Maintenance | 18 |
| 7.1 | General | 18 |
| 7.2 | Maintenance Instructions | 18 |
| 7.3 | Repressurising the System | 19 |
| 7.4 | Venting the System | 20 |
| 7.5 | Draining the System | 21 |

| | | |
|-----------|---|-----------|
| 8 | Troubleshooting | 22 |
| 8.1 | Error Codes | 22 |
| 8.2 | Fault Finding | 23 |
| 9 | Decommissioning | 24 |
| 9.1 | Decommissioning Procedure | 24 |
| 10 | Disposal | 24 |
| 10.1 | Disposal / Recycling | 24 |
| 11 | Environmental | 25 |
| 11.1 | Energy Saving | 25 |
| 11.2 | Room Thermostats and Settings | 25 |
| 12 | Warranty | 26 |
| 12.1 | General | 26 |
| 12.2 | Terms of Warranty | 26 |
| 12.2.1 | Standard Warranty Terms and Conditions | 26 |
| 13 | Appendix | 28 |
| 13.1 | ErP Information | 28 |
| 13.1.1 | Product Fiche - Combination Boilers | 28 |
| 13.1.2 | Package Fiche - Boilers | 29 |
| 13.1.3 | Package Fiche - Combination Heaters (Boilers or Heat Pumps) | 31 |

1 Introduction

1.1 General

Warning

This boiler can be used by children aged 8 years and above and by persons with reduced physical, sensory or mental capabilities or lack of experience and knowledge when they have been given supervision or instruction concerning the safe use of the device and understand the resulting risks. Children must not be allowed to play with the appliance. Cleaning and user maintenance must not be carried out by children without supervision.



WARNING

Installation, repair and maintenance must only be carried out only by a competent person. This document is intended for use by competent persons,

All Gas Safe registered engineers carry an ID card with their licence number and a photograph. You can check your engineer is registered by telephoning 0800 408 5500 or online at www.gassaferegister.co.uk

This manual is intended for the user of the Baxi EcoBlue Plus Combi boiler. If the appliance is sold or transferred, or if the owner moves leaving the appliance behind you should ensure that the manual is kept with the appliance for consultation by the new owner and their installer.

The appliance is designed as a boiler for use in residential domestic environments on a governed meter supply only. The selection of this boiler is entirely at the owner's risk. If the appliance is used for purposes other than or in excess of these specifications, the manufacturer will not accept any liability for resulting loss, damage or injury.

The manufacturer will not accept any liability whatsoever for loss, damage or injury arising as a result of failure to observe the instructions for use, maintenance and installation of the appliance.

1.2 Additional Documentation

Various timers, external controls, etc. are available as optional extras. Full details are contained in the relevant sales literature.

1.3 Symbols Used

In these instructions, various danger levels are employed to draw the user's attention to particular information. In so doing, we wish to safeguard the user's safety, prevent hazards and guarantee correct operation of the appliance.



DANGER

Risk of a dangerous situation causing serious physical injury.



WARNING

Risk of a dangerous situation causing slight physical injury.



CAUTION

Risk of material damage.



Signals important information .



Signals a referral to other instructions or other pages in the instructions.

1.4 Abbreviations / Glossary

- ▶ **DHW:** Domestic hot water
- ▶ **CH:** Central heating
- ▶ **GB:** Great Britain
- ▶ **IE:** Ireland
- ▶ **BS:** British standard
- ▶ **HHIC:** Heating and Hotwater Industry Council
- ▶ **Pnc:** Condensing output

1.5 Extent of Liabilities

1.5.1. Manufacturer's Liability

Our products are manufactured in compliance with the requirements of the various European applicable Directives. They are therefore delivered with **CE** marking and all relevant documentation. In the interest of customers, we are continuously endeavouring to make improvements in product quality. All the specifications stated in this document are therefore subject to change without notice.

The manufacturer will not accept any liability for loss, damage or injury arising as a result of:-

- ▶ Failure to abide by the instructions on using the appliance.
- ▶ Failure to regularly maintain the appliance, or faulty or inadequate maintenance of the appliance.
- ▶ Failure to abide by the instructions on installing the appliance.

This company declares that no substances harmful to health are contained in the appliance or used during appliance manufacture.

The appliance is suitable only for installation in GB and IE and should be installed in accordance with the rules in force, and only used in a suitably ventilated location.

In GB, the installation must be carried out by a Gas Safe Registered Installer. It must be carried out in accordance with the current and relevant requirements of legislation and guidance.

Where no specific instructions are given, reference should be made to the relevant British Standard Code of Practice.

In IE, the installation must be carried out by a competent Person and installed in accordance with the current edition of I.S. 813 'Domestic Gas Installations', the current Building Regulations and reference should be made to the current ETCI rules for electrical installation.

Incorrect installation could invalidate the warranty and may lead to prosecution.

1.5.2 Installer's Responsibility

The installer is responsible for the installation and initial start up of the appliance. The installer must adhere to the following instructions:

- ▶ Read and follow the instructions given in the manuals provided with the appliance.
- ▶ Carry out installation in compliance with the prevailing legislation and standards.
- ▶ Ensure the system is flushed and inhibitor added.
- ▶ Install the flue/chimney system correctly ensuring it is operational and complies with prevailing legislation and standards, regardless of location of the boiler's installation.
- ▶ Only the installer should perform the initial start up and carry out any checks necessary.
- ▶ Explain the installation to the user.
- ▶ Complete the Benchmark Commissioning Checklist in the Installation Manual - this is a condition of the warranty !
- ▶ Warn the user of the obligation to check the appliance and maintain it in good working order.
- ▶ Give all the instruction manuals to the user.

1.5.3. User's Responsibility

To guarantee optimum operation of the installation, you must observe the following instructions:

- ▶ Read and observe the instructions given in the manuals supplied with the appliance.
- ▶ Seek the assistance of a qualified installer for the installation and initial commissioning.
- ▶ Ask the installer to explain the installation.
- ▶ Have the required annual inspection and maintenance carried out by a qualified installer and ensure the Benchmark Service Record in the Installation Manual is completed - this is a condition of the warranty !
- ▶ Keep the manuals in good condition and near to the appliance.

This appliance must not be used by people with a lack of experience or knowledge, unless they are supervised by someone familiar with the appliance or if they have been instructed on how to operate the appliance correctly. Do not allow children to operate or play with the appliance.

2 Safety

2.1 General Safety Instructions



DANGER

If you smell gas:

1. Turn off the gas supply at the meter
2. Open windows and doors in the hazardous area
3. Do not operate light switches
4. Do not operate any electrical equipment
5. Do not use a telephone in the hazardous area
6. Extinguish any naked flame and do not smoke
7. Warn any other occupants and vacate the premises
8. Telephone the National Gas Emergency Service on:- 0800 111 999



If a water or gas leak occurs or is suspected, the boiler can be isolated at the inlet valves by turning their taps through 90° (1/4 turn) downwards

For advice please contact your Installer, Annual Service Provider or **Baxi Customer Support** - The Service Division of Baxi. You can contact **Baxi Customer Support** on telephone number **0344 871 1545**.

When contacting **Baxi Customer Support** it will be useful to have the '**Benchmark Checklist**' at the back of the Installation & Service Manual to hand as it includes details relevant to the boiler and installation.



WARNING

Do not touch flue/chimney pipes. Depending on the settings of the appliance, the temperature of flue/chimney pipes may exceed 60 °C.

Do not touch radiators for long periods. Depending on the settings of the appliance, the temperature of radiators may reach 85 °C.

Take precautions with domestic hot water. Depending on the settings of the appliance, domestic hot water temperature may reach 65 °C.



CAUTION

Do not neglect to service the appliance. Contact a qualified professional or take out a maintenance contract for the annual servicing of the appliance.

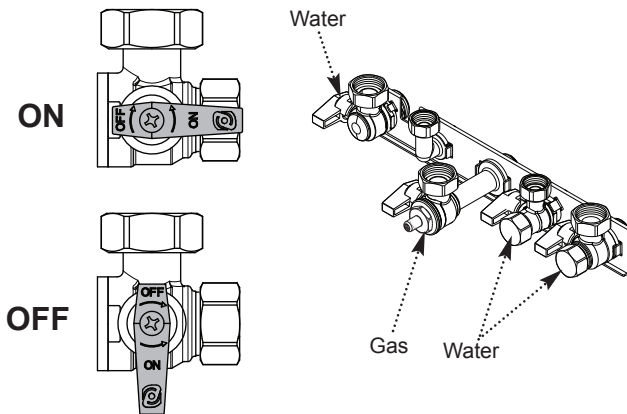

2.2 Recommendations



CAUTION

Only qualified professionals are authorised to work on the appliance and the installation.

The appliance has an integral frost protection mode as long as there is power to the boiler.



Regularly check the water pressure in the system (recommended pressure is 1.5 bar).



See section 7.4.

Keep the appliance accessible at all times.

Do not remove or cover the user information and serial number labels affixed to the boiler control flap. They must remain legible throughout the lifetime of the appliance

2.2.1 Benchmark Commissioning Checklist

1. Please ensure that the installer has fully completed the Benchmark Checklist on the inside back pages of the installation instructions supplied with the product and that you have signed it to say that you have received a full and clear explanation of its operation. The installer is legally required to complete a commissioning checklist as a means of complying with the appropriate Building Regulations (England and Wales).
2. All installations must be notified, by the installer, to Local Area Building Control either directly or through a Competent Persons Scheme. A Building Regulations Compliance Certificate will then be issued to the customer who should, on receipt, write the Notification Number on the Benchmark Checklist.
3. This product should be serviced annually to optimise its safety, efficiency and performance. The service engineer should complete the relevant section of the Benchmark Service Record in the Installation & Service Manual after each service.
4. The completed Benchmark Checklist & proof of annual servicing (where applicable) will be required in the event of any warranty work.



See section 12 for warranty information.

3 Technical Specifications

3.1 Technical Data

| | |
|-------------------------------|--|
| Temperatures | |
| C.H. Flow Temp (adjustable) | 25°C to 80°C max (± 5°C) |
| D.H.W. Flow Temp (adjustable) | 40°C to 60°C max (± 5°C) dependent upon flow rate |

| | |
|--|-----|
| Central Heating Primary Circuit Pressures | |
| | bar |
| Safety Discharge | 3 |
| Max Operating | 2.5 |
| Min Operating | 0.5 |
| Recommended Operating Range | 1-2 |

| | | | |
|------------------------------|------|--|--|
| DHW Circuit Pressures | bar | | |
| Max Operating | 8 | | |
| Min Operating | 0.15 | | |

| | | | |
|----------------------------|-------|-------|-------|
| Flow Rates | (24) | (28) | (33) |
| | l/min | l/min | l/min |
| DHW Flow Rate @ 35° C Rise | 9.8 | 11.5 | 13.5 |
| Min Working DHW Flow Rate | 2 | 2 | 2 |

IMPORTANT: Where Low Flow Taps or Fittings are intended to be used in the DHW system connected it is strongly recommended that the DHW flow rate DOES NOT fall below 2.5 l/min. This will ensure reliable operation of the DHW function.

| | |
|--|------------|
| Electrical Supply | 230V~ 50Hz |
| (Appliance must be connected to an earthed supply) | |

| | |
|------------------------------|--|
| Electrical Protection | IPX5D (without integral timer) IP20 (with integral timer) |
|------------------------------|--|

| | |
|-----------------------------|----|
| External Fuse Rating | 3A |
|-----------------------------|----|

NOTE: All data in this section are nominal values and subject to normal production tolerances.

Dimensions & Clearances These must be maintained in the event of any alteration in the property, e.g. additional cupboards etc.

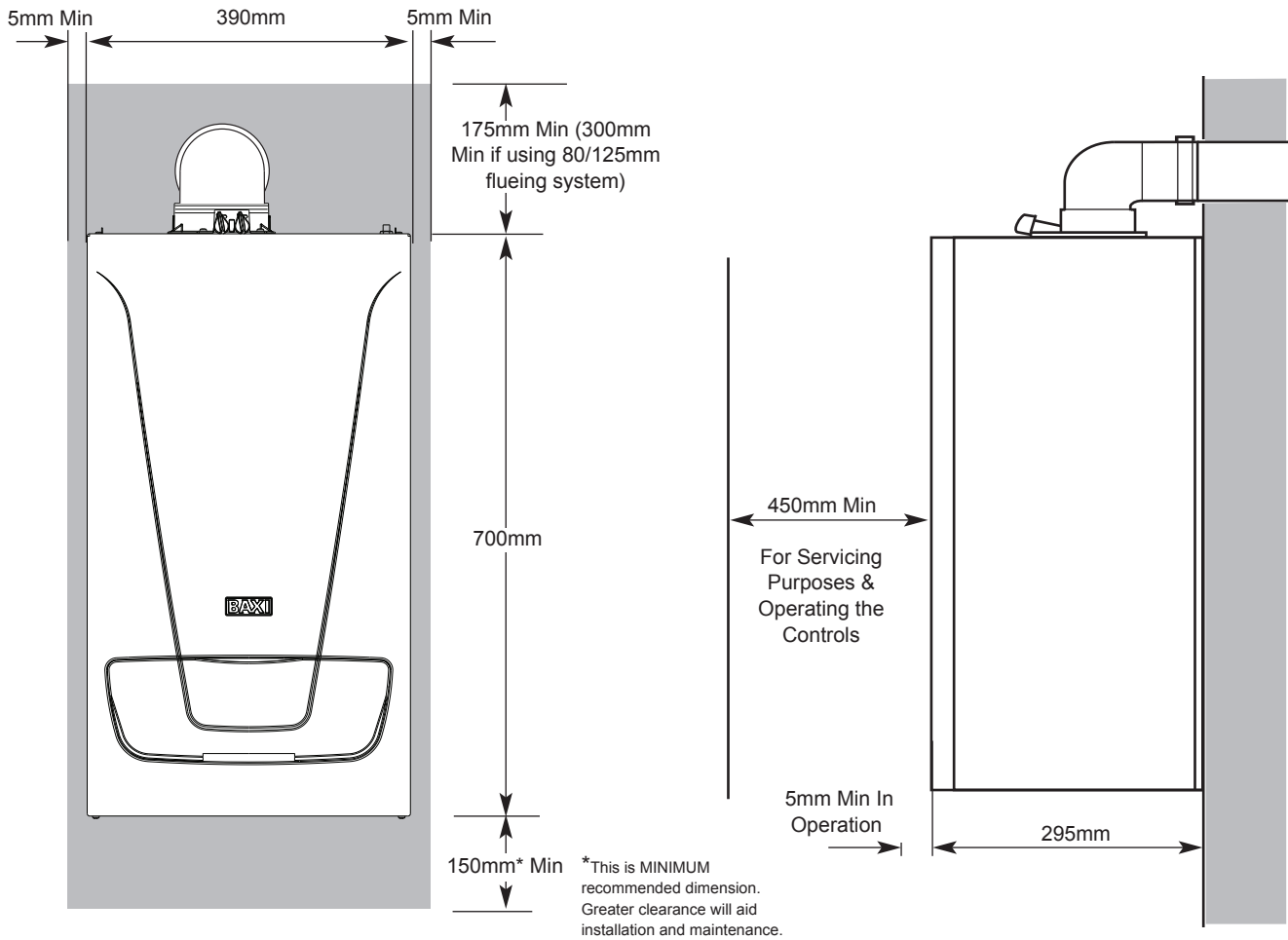

4 Description of the Product

4.1 General Description

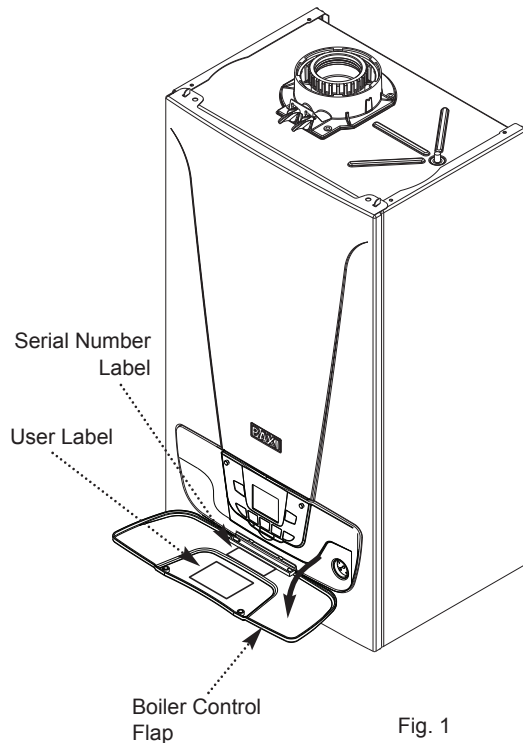

Fig. 1

1. The Baxi EcoBlue Plus Combi range of fully automatic gas fired wall mounted condensing combination boilers are room sealed and fan assisted, and will serve central heating and mains fed domestic hot water.



2. The boiler is set to give a maximum output of :-

| | |
|------------|-----------------------------|
| 24 model - | 24 kW DHW |
| | 21.2 kW CH Pnc (Condensing) |
| 28 model - | 28 kW DHW |
| | 25.3 kW CH Pnc (Condensing) |
| 33 model - | 33 kW DHW |
| | 29.6 kW CH Pnc (Condensing) |

3. The boiler is factory set for use only on Natural Gas (G20).

4. Priority is given to domestic hot water.

5. The boiler model, serial number and Gas Council number are also shown on the information label behind the boiler control flap (Fig. 1). This is for user reference.

 The boiler can be set in 3 operating modes:- 'Summer' (DHW only), 'Winter' (CH & DHW) or 'Heating Only' (CH only) by use of the  button - see Section 6.1.

4.2 Operating Principle

4.2.1 In Operation

1. Whilst the boiler is in operation cooled flue gases are discharged through the flue gas discharge pipe. This may appear as a cloud of steam which is normal.

2. Condensed water is discharged from the boiler heat exchanger into a pipe (the condensate drain). This pipe must never be altered or re-routed except by a qualified professional.

4.3 Control Panel Description

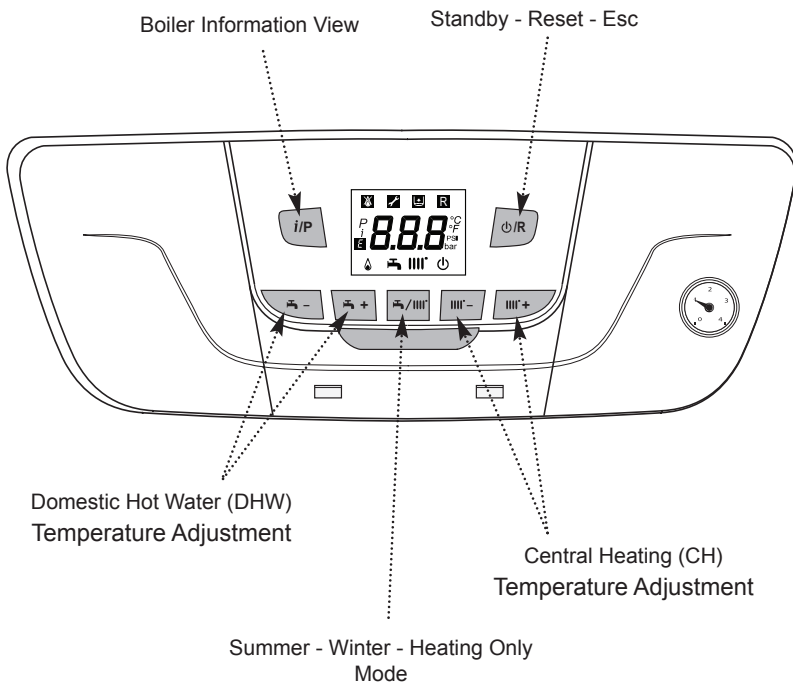

Key to Controls

- Standby - Reset - Esc Button
- Boiler Information View Button
- Increase CH Temperature Button
- Decrease CH Temperature Button
- Increase DHW Temperature Button
- Decrease DHW Temperature Button
- Summer / Winter / Only Heating Mode Button
 - Summer - DHW only mode
 - Winter - DHW & CH mode
 - Heating Only - Only CH mode

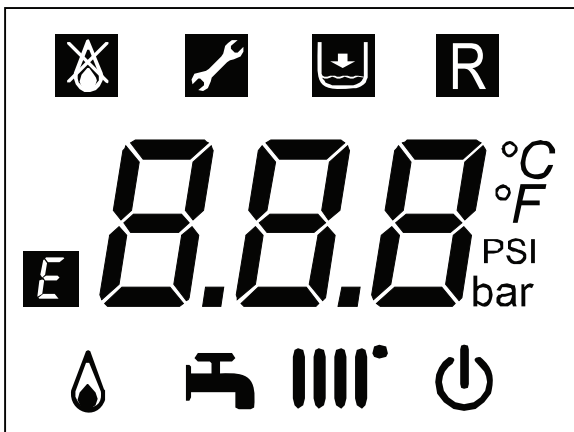

Display Description

- DHW and CH OFF (frost protection still enabled)
- See Section 5.2 for information
- Indicates an error that prevents burner from igniting
- Error - Not resettable by user
- Water pressure too low
- Indicates an error resettable by the user
- Generic error
- Burner lit
- DHW mode (symbol will flash with demand)
- Heating mode (symbol will flash with demand)
- Units for temperature
- Units for temperature
- Units for pressure
- Units for pressure
- Service due

4.4 Standard Delivery

1. The literature pack contains:

- ▶ Literature pack
 - Installation & Servicing Instructions (including 'Benchmark')
 - User Guide Instructions
 - Flue Accessories & Fitting Guide
 - Service Contract Leaflet
 - Registration Card
 - Envelope
 - Fernox Leaflet
 - Wall Template
 - Product Leaflet
 - Package Leaflet

4.5 Accessories & Options

4.5.1 Optional Extras

1. Various timers, external controls, etc. are available as optional extras.

- ▶ Outdoor Sensor - Wired
- ▶ Mechanical Thermostat
- ▶ Mechanical Timer (24 hr) - Plug-in
- ▶ Digital Timer (7 day) - Plug-in
- ▶ Single Channel Timer - Wired
- ▶ Two Channel Timer - Wired
- ▶ RF Digital Programmable Room Unit - Wireless
- ▶ RF Mechanical Programmable Room Unit - Wireless
- ▶ Condensate Discharge Pump and Pipe 'Trace Heating'
- ▶ Flue Accessories (elbows, extensions, clamps etc.)
(refer to the Flue Accessories & Fitting Guide supplied in the literature pack.)
- ▶ Remote relief valve kit
- ▶ Boiler discharge pump
- ▶ 1M Condensate Drain Pipe 'Trace Heating' Element
- ▶ 2M Condensate Drain Pipe 'Trace Heating' Element
- ▶ 3M Condensate Drain Pipe 'Trace Heating' Element
- ▶ 5M Condensate Drain Pipe 'Trace Heating' Element

Any of the above MUST be fitted ONLY by a qualified competent person. Further details can be found in the relevant sales literature and at www.baxi.co.uk

5 Operation

5.1 Operation Checking Procedure & Basic Fault Identification

IMPORTANT: Where Low Flow Taps or Fittings are intended to be used in the DHW system connected it is strongly recommended that the DHW flow rate DOES NOT fall below 2.5 l/min. This will ensure reliable operation of the DHW function.

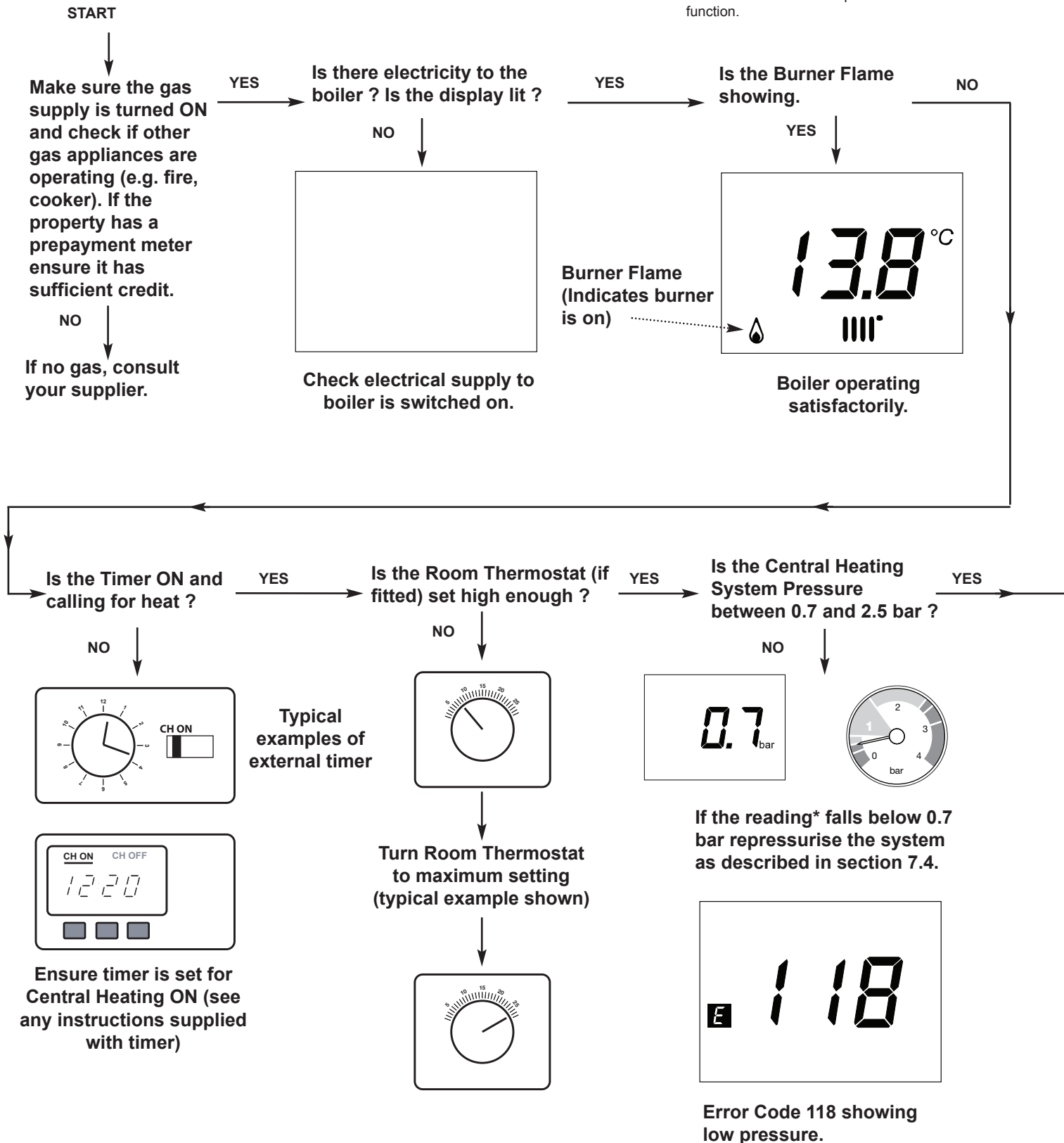

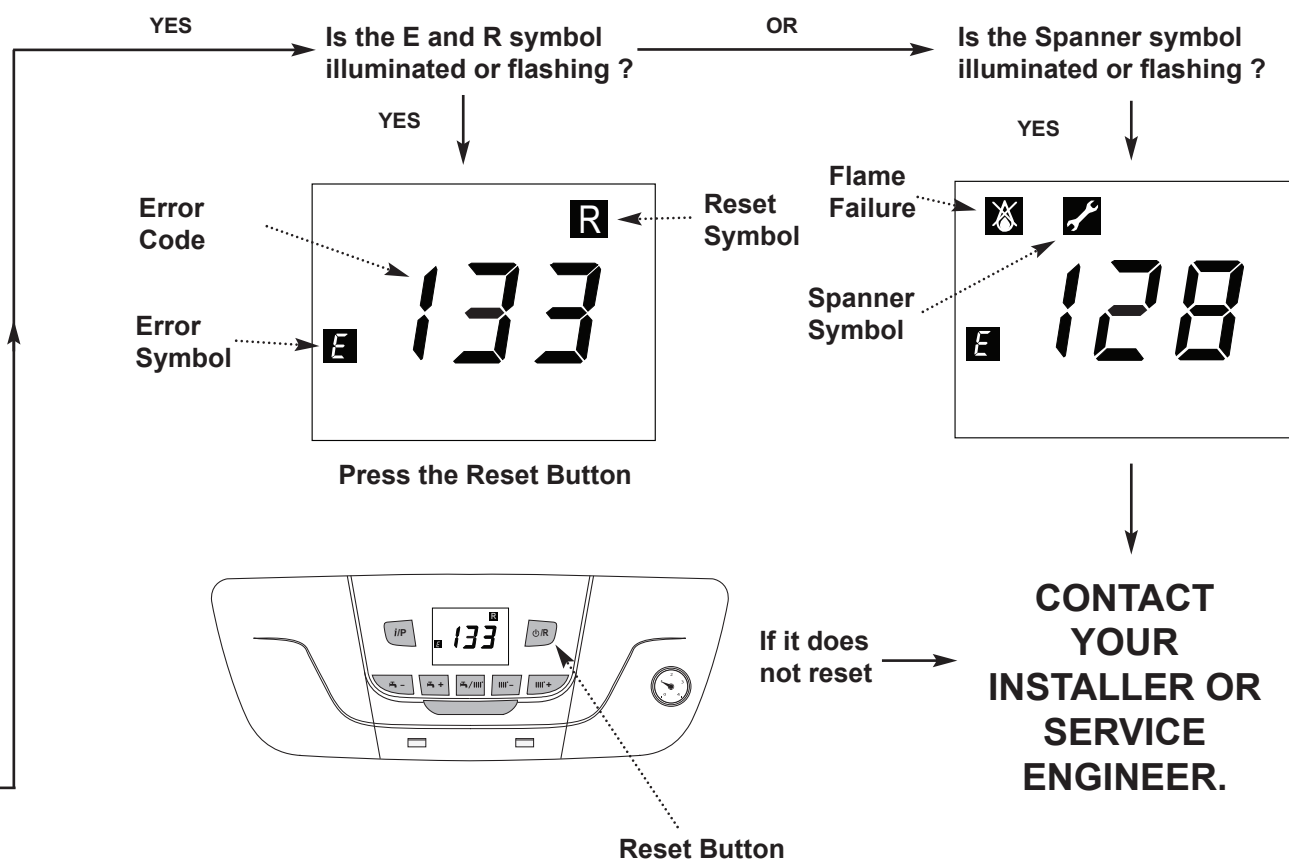

*To display the water pressure press *iP* until *i05* is shown.

i05 will alternate with the system pressure.
 (NOTE: When the pump is running the gauge under the boiler may show a slightly different reading to the display)

If you don't know what you need to do to get the boiler to light, or need help with the system and controls, contact your installer as soon as possible

5.2 Shutdown

1. If it is anticipated that the boiler will not be used for a long period or the property is to be unoccupied it is recommended that the system drained if the electricity & gas supplies are to be turned off. Your installer will be able to offer advice.

5.3 Frost Protection

1. The boiler incorporates an integral frost protection feature that will operate in both Central Heating and Domestic Hot Water modes, and also when in standby ( displayed).

2. If the boiler temperature falls below 5°C, then the boiler will operate until the water temperature has been raised.

3. Further protection may be required for the system. Consult your installer for details.

6 Settings

6.1 Setting the Boiler Temperatures

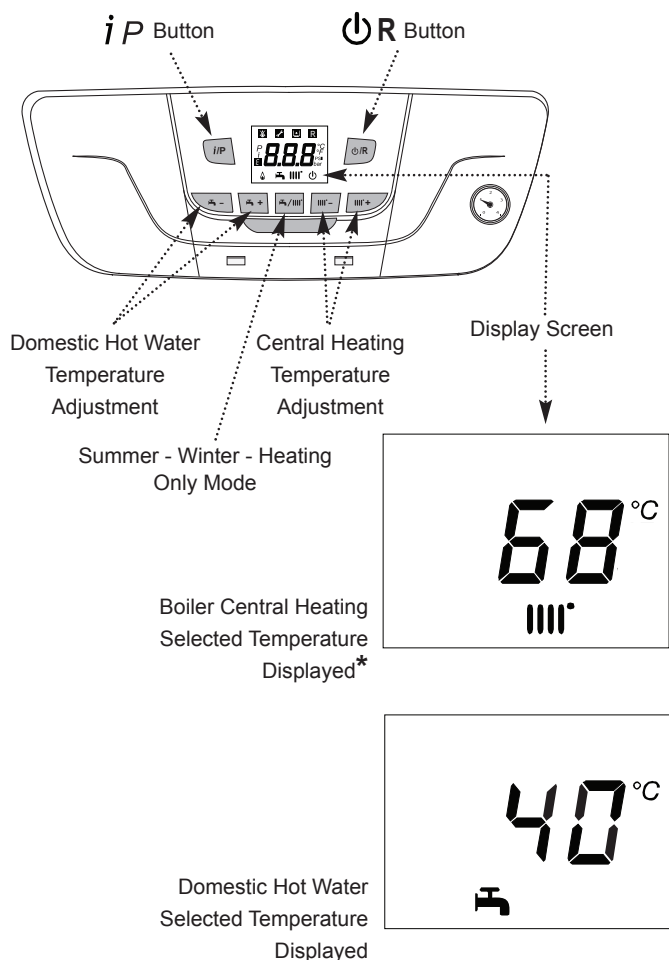

The values displayed are the temperature as measured at the boiler, not necessarily that at the radiator or tap. Because of differences in systems, seasonal variations in mains water temperature etc. some adjustment of the temperatures may be required to achieve the desired results. Your installer will be able to offer advice.

*Where Outdoor Sensor fitted

If the control system includes an Outdoor Sensor the temperature display and Central Heating buttons perform different functions than those described.

Display - This shows a simulated room temperature set point, NOT the boiler temperature.

Buttons - They will alter the displayed temperature, and for optimum use should be used to change the displayed temperature to the same as selected on the room thermostat.

By selecting a temperature different to the room thermostat altered comfort levels will be achieved. Your installer will be able to offer advice.

6.1.1 Boiler Temperature

To increase or decrease the boiler temperature:-

1. Press **|||+** to increase the Central Heating temperature.*
2. Press **|||-** to decrease the Central Heating temperature.*



If **|||+** and **|||-** are pressed together P02 will be displayed. Pressing either button again will scroll through the display and P26 & P64 will be shown. Press **P** to return to normal display.

6.1.2 Domestic Hot Water Temperature

To adjust the domestic hot water temperature:-

1. Press **⌚+** to increase the Domestic Hot Water temperature.
2. Press **⌚-** to decrease the Domestic Hot Water temperature.

6.1.3 Summer - Winter - Heating Only Mode

1. Press **⌚/|||** button until the required mode appears:-

⌚ Summer - Domestic Hot Water only mode

⌚ ||| Winter - Domestic Hot Water & Central Heating mode

||| Heating Only - Only Central Heating mode



In Heating Only mode Domestic Hot Water will NOT be supplied when a hot tap is opened.



See 6.1.1 or 6.1.2 to set the required temperature.

6.1.4 Information Display

1. The table opposite shows information that can be displayed by pressing the **iP** button.
2. Depending upon boiler model and any system controls connected to the appliance, not all information codes will be displayed and some that are will not have a value.
3. Press **P** to return to the normal display.

7 Maintenance

7.1 General

1. The boiler does not require any special maintenance. However, the boiler must be serviced annually in accordance with the Installation and Service Manual and the relevant section of the Benchmark Service Record completed in order to maintain the warranty.



Taking out a maintenance contract is recommended.



CAUTION

Maintenance operations must be performed by a qualified competent person.

Use only genuine spare parts.

2. The painted panels should be wiped with a damp cloth and then dried completely. **DO NOT USE ABRASIVE CLEANING AGENTS.**

7.2 Maintenance Instructions

1. The central heating system should be checked regularly. Proceed as follows:

- Check the water pressure in the central heating system.



If the water pressure is lower than 0.7 bar, the water must be topped up. If necessary: top up the CH system (recommended water pressure between 1 and 1.5 bar when the system is cold).

- Check radiators for leaks and (especially in damp areas) for rust.
- Open and close the radiator valves several times a year to ensure they can still be rotated.
- Only clean the outside of the boiler with a damp cloth. Do not use abrasive cleaning agents.



CAUTION

Only a qualified installer may clean the inside of the boiler.

7.3 Re-pressurising the System

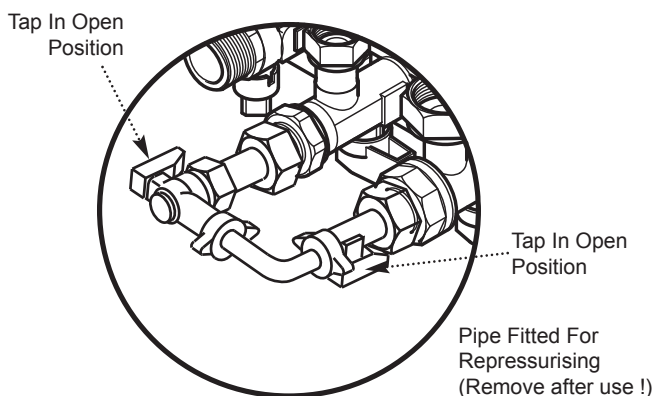
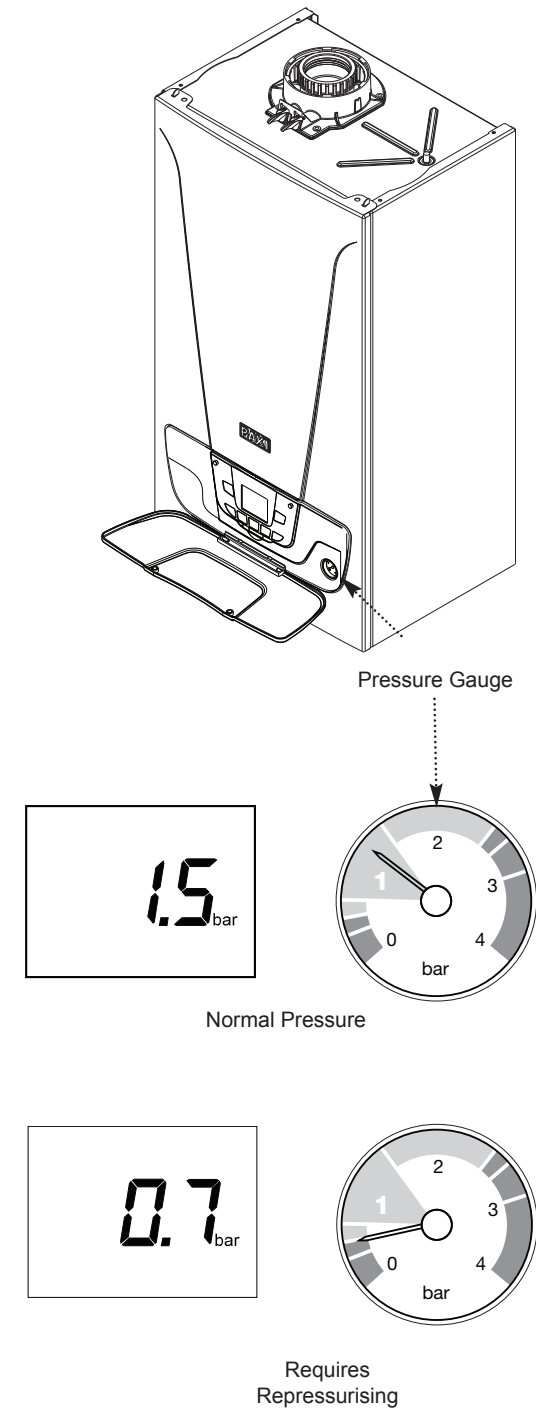

1. If the water pressure is too low, the system must be re-pressurised.
2. The normal operating water pressure is between 1 and 2 bar. If the pressure exceeds 3 bar the safety pressure valve will operate and a fault is indicated (E117 displayed). Ensure that the filling loop is disconnected. Contact your installer.
3. It may be necessary to repressurise the system occasionally (when the water pressure falls below 0.7 or E118 displayed). A filling device (the filling loop) will be fitted on the system. This will be on the boiler itself, or on pipework near to the boiler.

If the water pressure requires regular re-pressurising a fault or leak is indicated. Seek advice from your installer.

4. If you are unsure of its position, or cannot identify it, consult the installer who fitted the boiler.
5. The filling loop consists of two isolating taps and a separate filling pipe with connection fittings.
6. Only when repressurising should the filling pipe be connected between the two taps. Ensure that the nuts on the pipe ends are tightened onto the taps.
7. Fully open one of the taps first, and then while watching the pressure gauge, carefully open the second tap.
8. The system pressure is shown at all times on the pressure gauge and can be viewed on the display when there is power to the boiler.
9. To check the water pressure on the boiler display press **iP** until **i 05** is shown. This will alternate with the system pressure. (When the pump is running the pressure gauge may show a slightly different reading to the display).
10. When the figures on the display or needle on the pressure gauge indicate between 1 and 1.5 bar turn both taps off.

11. Disconnect the filling pipe from the taps (a small amount of water may be present) and remove it. Keep the pipe in a safe place for future use.

12. If blanking caps are available fit them to the taps.

Go to the 'How to videos' section of the 'Information & advice' page at www.baxi.co.uk for further details.

13. When the correct pressure is restored the boiler will reset automatically.

7.4 Venting the System

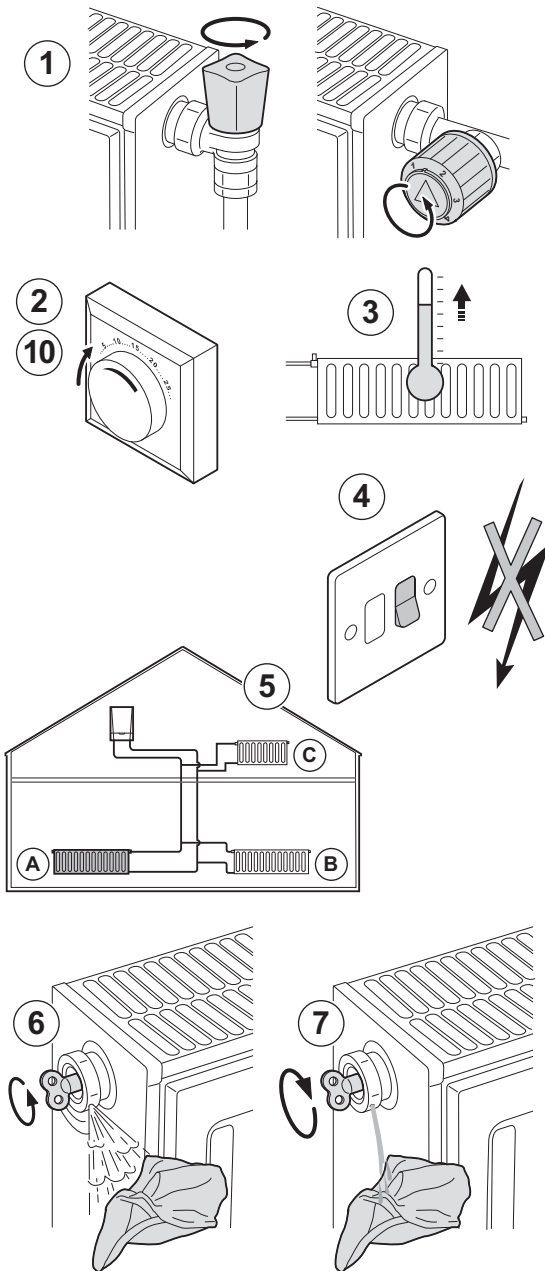

1. If any air is present in the appliance or system it must be removed in order to prevent nuisance noises that may occur during heating or when drawing off hot water. Proceed as follows:

1. Open the valves of all the radiators connected to the system.
2. Set the room thermostat to the highest possible temperature and any timers to 'ON'.
3. Wait until the radiators are warm.
4. Switch off the boiler.
5. Vent the radiators. Work from the lowest radiator in the property.
6. Open the bleed vent with the key, keeping a cloth pressed against the vent.
7. Wait until water comes out of the bleed vent and then close.



WARNING

The CH water in the radiators will still be hot.

8. Switch the boiler on.
9. After venting, check that the water pressure in the system is still adequate.

 If the water pressure is lower than 0.7 bar, the water must be topped up. If necessary repressurise the system (recommended pressure between 1 and 1.5 bar when cold) - see Section 7.3

10. Reset the room thermostat to the desired temperature.

7.5 Draining the System

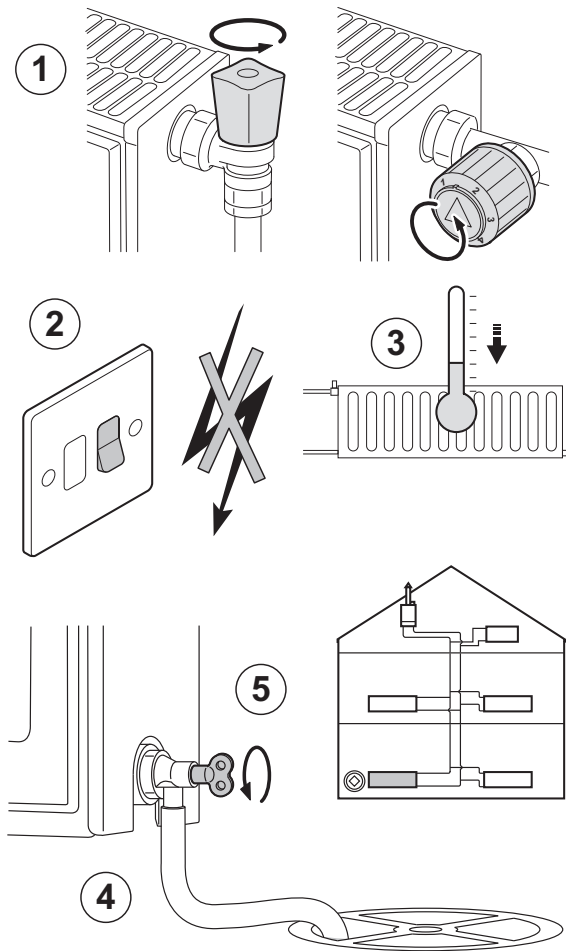

1. It may be necessary to drain the CH system if radiators need to be replaced or removed, if there is a major water leak or if there is a risk of freezing. Proceed as follows:

1. Open the valves of all the radiators connected to the system.
2. Switch off or disconnect the boiler's electrical isolation point.
3. Wait until all the radiators are cold.
4. Connect a drain hose to the lowest draining point. Place the end of the hose in a drain or at a place where drained water will not cause any damage.
5. Open the CH system drain valve. Drain the system.



WARNING

The CH water may still be hot.

6. When water stops flowing from the draining point, close the draining valve.

 See Sections 7.3 & 7.4 for Re-pressurising & Venting the system. If in doubt seek advice from your installer.

 After draining and re-pressurising the concentration of system corrosion inhibitor and anti-freeze may become excessively diluted - seek advice from your installer.

8 Troubleshooting

8.1 Error Codes

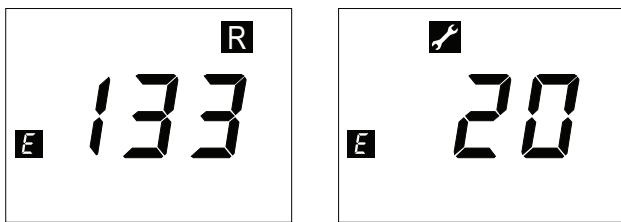
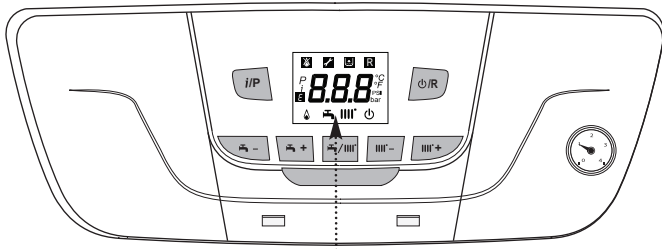

Examples of Error Codes

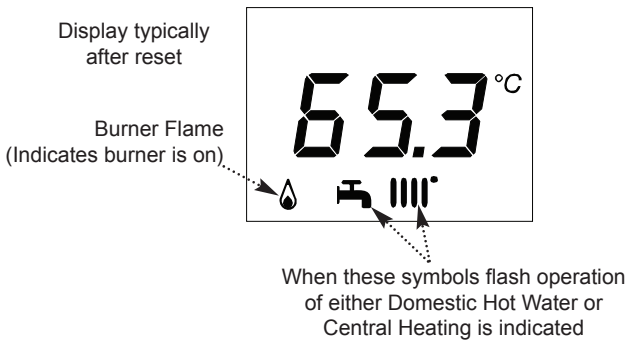

1. In the unlikely event of an error occurring the display will show one of two symbols or **R**. In both cases the display will also show **E** symbol and the numeric value of the error (see the 'Table of Error Codes').

2. When the spanner is displayed the error cannot be reset by the user. Please contact your Installer, Annual Service Provider or **Baxi Customer Support** - The Service Division of Baxi to arrange your Annual Service. You can contact **Baxi Customer Support** on **0344 871 1545**.

When contacting **Baxi Customer Support** it will be useful to have the '**Benchmark Checklist**' at the back of the Installation & Service Manual to hand as it includes details relevant to the boiler and installation.

3. **R** fault errors can be reset by pressing the button and holding for two seconds.

Error Code 118 can be reset by restoring the correct system pressure as described in Section 7.3.



WARNING

If an error code different from those described in the 'Table of Error Codes' appears on the display or a certain fault appears frequently, contact **Baxi Customer Support**.

Table Of Error Codes

| | |
|-----------------------|---|
| E 20 | Central Heating NTC Fault |
| E 28 | Flue NTC Fault |
| E 40 | Central Heating Return NTC Fault |
| E 110 R | Safety Thermostat Operated (pump fault) |
| E 111 R | Safety Thermostat Operated (over temperature) |
| E 117 | Primary System Water Pressure Too High |
| E 118 | Primary System Water Pressure Too Low |
| E 125 R | Circulation Fault (Primary) |
| E 128 | Flame Failure (no lock-out) |
| E 130 | Flue NTC Operated |
| E 133 R | Interruption Of Gas Supply or Flame Failure |
| E 151 R | Flame Failure |
| E 160 R | Fan or Fan Wiring Fault |
| E 321 | Hot Water NTC Fault |
| E 384 | False Flame |

8.2 Fault Finding

1. If the boiler is not working also check section 5.3 Operation Checking Procedure & Basic Fault Identification or contact your Installer.

| Problem | Possible Causes | Solution |
|---------------------------------|--|--|
| There is no domestic hot water. | <p>The boiler is not working.</p> <p>The DHW function is switched off.</p> <p>The water pressure is too low (< 0.5 bar).</p> <p>Insufficient flow.</p> | <p>Check that the boiler is being supplied with power. Check fuses and the switches.</p> <p>Check whether the gas valve is properly open. If the property has a prepayment meter ensure it has sufficient credit.</p> <p>Activate the DHW mode.</p> <p>Re-pressurise the system.</p> <p>Flow must be at least 2.5 litres per minute.</p> |
| The radiators are cold. | <p>The temperature set point for the heating is too low.</p> <p>The heating mode is deactivated.</p> <p>The radiator valves are not open.</p> <p>The boiler is not working.</p> <p>The water pressure is too low (< 0.5 bar).</p> | <p>Increase the value with the CH temperature button or if a room thermostat is connected, increase the temperature on the room thermostat.</p> <p>Activate the heating mode.</p> <p>Open the valves of all radiators connected to the system.</p> <p>Check that the boiler is being supplied with power. Check fuses and switches.</p> <p>Check whether the gas isolation valve is properly open. If the property has a prepayment meter ensure it has sufficient credit.</p> <p>Re-pressurise the system.</p> |
| The boiler is not working. | <p>The temperature set point for the heating is too low.</p> <p>No demand for heating.</p> <p>No power supply.</p> <p>The water pressure is too low (< 0.5 bar).</p> <p>The boiler is indicating an error.</p> <p>The gas pressure is too low.</p> <p>Condensate drain blocked.</p> | <p>Increase the value with the CH temperature button or if a room thermostat is connected, increase the temperature on the room thermostat.</p> <p>Ensure that timers & thermostats are calling for heat.</p> <p>Check that the boiler is being supplied with power. Check the fuses and switches.</p> <p>Re-pressurise the system.</p> <p>Press the Reset button  Correct the error, if possible.</p> <p>Check whether the gas isolation valve is fully open. Open the gas isolation valve.</p> <p>Check drain, especially any external runs in freezing temperatures.</p> |

9 Decommissioning

9.1 Decommissioning Procedure



CAUTION

Only qualified professionals are authorised to work on the appliance and system to decommission.

1. If your the boiler needs to be decommissioned either temporarily or permanently the following should be performed:

- Switch off the boiler.
- Switch off the boiler's electrical connection.
- Close the boiler gas valve.
- Drain the CH system.

Seek the advice of your installer.

10 Disposal

10.1 Disposal / Recycling



WARNING

Removal and disposal of the boiler must be carried out by a qualified installer in accordance with local and national regulations.

11 Environmental

11.1 Energy Saving

Tips on saving energy:

- ▶ Do not cover radiators. Do not hang curtains in front of radiators.
- ▶ Install reflective panels behind the radiators to prevent heat losses.
- ▶ Insulate the pipes in rooms that are not heated (cellars and lofts).
- ▶ Install loft insulation & double glazing.
- ▶ Use draught excluders where necessary.
- ▶ Upgrade any older external controls.
- ▶ Turn down room thermostats by 1°C
- ▶ Turn off radiators in rooms not in use.
- ▶ Do not run hot (or cold) water pointlessly.
- ▶ Fit a water-saving shower head to save up to 40 % energy.
- ▶ Take showers rather than baths. A bath consumes twice as much water and energy.

11.2 Room Thermostats and Settings

Various models of room thermostat are available. The thermostat type and setting affect the total energy consumption.

A few tips:

- ▶ Fully opening or closing thermostatic radiator valves results in unwanted temperature fluctuations. Turn the thermostat knob or valve higher or lower in small steps.
- ▶ Lower the thermostat to approximately 20°C. This reduces heating costs and energy consumption.
- ▶ When rooms are to be aired lower the thermostat well in advance.
- ▶ When setting thermostats or programmers take account of days when nobody will be in and holidays.

12 Warranty

12.1 General

To make sure your boiler warranty is activated and maintained, it is essential that the:

1. Benchmark checklist is completed by your installer
2. Warranty is registered within 30days
3. Boiler has an annual service

Please note that failure to adhere to terms and conditions will make your warranty invalid.

12.2 Terms of Warranty

12.2.1 Standard Warranty Terms and Conditions

Warranty Registration, Service & Repair

For full terms and conditions, visit www.baxi.co.uk/terms.

Benchmark Checklist

The Benchmark Checklist will be completed by your installer and records that the boiler has been installed and commissioned correctly. It can be found at the back of the installation and service manual and should be kept in a safe place for the life of the boiler. We will check that the Benchmark Checklist has been completed on an in-warranty visit.

Ways to register your warranty

If your boiler is eligible for an extended warranty, your installer may register the product on your behalf and provide you with the relevant documentation. Please check with your installer.

Should this not be the case, you can register your warranty online at www.baxi.co.uk/registration

Annual Service

A service must be completed every 12 months from the date of installation to maintain your warranty.

This service must be completed by one of the following:

- A Gas Safe registered installer/engineer
- Baxi Customer Support; call us 0344 871 1545

Please make sure that your engineer has logged the service information at the back of the installation and service manual. You will be asked for your service history on any in-warranty repair visit.

If you experience a problem with your boiler

For any in or out of warranty repair, Baxi Customer Support is on hand to help you. Call our award-winning team to arrange for one of our nationwide team of Gas Safe registered engineers to visit.

If your product is in warranty, everything is free of charge, subject to our warranty terms and conditions. If it is out of warranty, we can still help and offer a range of options you can choose from to suit your needs.

Contact Baxi Customer Support 0344 871 1545

Opening hours

Monday - Friday, 8.00am - 6.00pm

Weekends and Bank Holidays, 8.30am - 2.00pm

Please note calls may be recorded for training and monitoring purposes.

When contacting Baxi Customer Support, please have the following information to hand:

- Boiler serial number. This can be found on the appliance.
- Proof of purchase if you do not have the boiler serial number.

Please note that for in-warranty repairs, our engineers will ask to see your service history record, completed Benchmark Checklist and details of your installer. These can all be found in the installation and user manual.

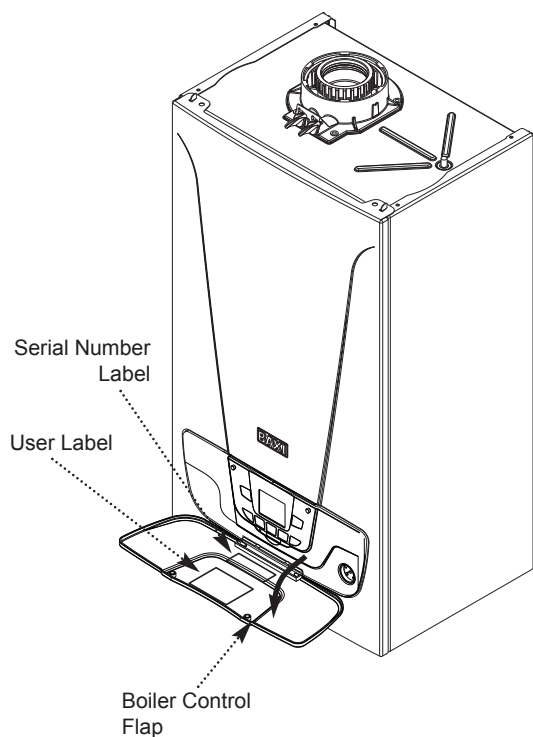

13 Appendix

13.1 ErP Information

13.1.1 Product Fiche - Combination Boilers

Product fiche for combination boilers

| Baxi EcoBlue Plus Combi ErP | | 24 | 28 | 33 |
|--|-----------|-------------|-------------|-------------|
| Space heating - Temperature application | | Medium | Medium | Medium |
| Water heating - Declared load profile | | XL | XL | XXL |
| Seasonal space heating energy efficiency class | | A | A | A |
| Water heating energy efficiency class | | A | A | A |
| Rated heat output (<i>Prated or Psup</i>) | kW | 20 | 24 | 28 |
| Space heating - Annual energy consumption | kWh GJ | 17204 62 | 20645 74 | 24086 87 |
| Water heating - Annual energy consumption | kWh GJ | 16 | 17 | 22 |
| Seasonal space heating energy efficiency | % | 93 | 93 | 93 |
| Water heating energy efficiency | % | 90 | 88 | 86 |
| Sound power level L_{WA} indoors | dB | 51 | 52 | 53 |



See

For specific precautions about assembling, installing and maintaining, consult the relevant section as detailed on the Contents page.

13.1.2 Package Fiche - Boilers

Package fiche for boilers indicating the space heating energy efficiency of the package

Seasonal space heating energy efficiency of boiler

①
‘I’ %

Temperature control

from fiche of temperature control

Class I = 1%, Class II = 2%, Class III = 1.5%,
 Class IV = 2%, Class V = 3%, Class VI = 4%,
 Class VII = 3.5%, Class VIII = 5%

②
 + %

Supplementary boiler

from fiche of boiler

Seasonal space heating energy efficiency (in %)

③
 $(\text{ } - \text{‘I’}) \times 0.1 = \pm \text{ } \%$

Solar contribution

from fiche of solar device

Collector size (in m²)

Tank volume (in m³)

Collector efficiency (in %)

Tank rating ⁽¹⁾
 A* = 0.95, A = 0.91,
 B = 0.86, C = 0.83,
 D - G = 0.81

$$(\text{‘III’} \times \text{ } + \text{‘IV’} \times \text{ }) \times 0.9 \times (\text{ } / 100) \times \text{ } = + \text{ } \% \quad \text{④}$$

(1) If tank rating is above A, use 0.95

Supplementary heat pump

from fiche of heat pump

Seasonal space heating energy efficiency (in %)

⑤
 $(\text{ } - \text{‘I’}) \times \text{‘II’} = + \text{ } \%$

Solar contribution AND Supplementary heat pump

select smaller value

$$0.5 \times \text{ } \text{ OR } 0.5 \times \text{ } = - \text{ } \% \quad \text{⑥}$$

Seasonal space heating energy efficiency of package

⑦
 %

Seasonal space heating energy efficiency class of package

| | | | | | | | | | |
|--------------------------|--------------------------|--------------------------|--------------------------|--------------------------|--------------------------|--------------------------|--------------------------|--------------------------|--------------------------|
| <input type="checkbox"/> | <input type="checkbox"/> | <input type="checkbox"/> | <input type="checkbox"/> | <input type="checkbox"/> | <input type="checkbox"/> | <input type="checkbox"/> | <input type="checkbox"/> | <input type="checkbox"/> | <input type="checkbox"/> |
| G | F | E | D | C | B | A | A⁺ | A⁺⁺ | A⁺⁺⁺ |
| <30% | ≥30% | ≥34% | ≥36% | ≥75% | ≥82% | ≥90% | ≥98% | ≥125% | ≥150% |

Boiler and supplementary heat pump installed with low temperature heat emitters at 35°C ?

from fiche of heat pump

⑦
 + (50 x ‘II’) = %

The energy efficiency of the package of products provided for in this fiche may not correspond to its actual energy efficiency once installed in a building, as this efficiency is influenced by further factors such as heat loss in the distribution system and the dimensioning of the products in relation to building size and characteristics.

AD-3000743-01

- I The value of the seasonal space heating energy efficiency of the preferential space heater, expressed in %.
- II The factor for weighting the heat output of preferential and supplementary heaters of a package as set out in the following table.

13.1.2 Package Fiche - Boilers (cont)

- III The value of the mathematical expression: $294/(11 \cdot \text{Prated})$, whereby 'Prated' is related to the preferential space heater.
- IV The value of the mathematical expression $115/(11 \cdot \text{Prated})$, whereby 'Prated' is related to the preferential space heater.

Weighting of boilers

| $P_{\text{sup}} / (P_{\text{rated}} + P_{\text{sup}})^{(1)(2)}$ | II, package without hot water storage tank | II, package with hot water storage tank |
|---|--|---|
| 0 | 0 | 0 |
| 0.1 | 0.3 | 0.37 |
| 0.2 | 0.55 | 0.70 |
| 0.3 | 0.75 | 0.85 |
| 0.4 | 0.85 | 0.94 |
| 0.5 | 0.95 | 0.98 |
| 0.6 | 0.98 | 1.00 |
| ≥ 0.7 | 1.00 | 1.00 |

(1) The intermediate values are calculated by linear interpolation between the two adjacent values.
(2) Prated is related to the preferential space heater or combination heater.

Package efficiency

| Baxi EcoBlue Plus Combi ErP | | 24 | 28 | 33 |
|------------------------------------|---|-----------|-----------|-----------|
| Temperature control X | % | | | |
| Temperature control Y | % | | | |

13.1.3 Package Fiche - Combination Heaters (Boilers or Heat Pumps)

Package fiche for combination heaters (boilers or heat pumps) indicating the water heating energy efficiency of the package

Water heating energy efficiency of combination heater

①
 %

Declared load profile:

Solar contribution

from fiche of solar device

Auxiliary electricity

②
 $(1.1 \times 'I' - 10\%) \times 'II' - 'III' - 'I' = +$ %

Water heating energy efficiency of package under average climate

③
 %

Water heating energy efficiency class of package under average climate

| | <input type="checkbox"/> | <input type="checkbox"/> | <input type="checkbox"/> | <input type="checkbox"/> | <input type="checkbox"/> | <input type="checkbox"/> | <input type="checkbox"/> | <input type="checkbox"/> | <input type="checkbox"/> | <input type="checkbox"/> |
|-------------------------------------|--------------------------|--------------------------|--------------------------|--------------------------|--------------------------|--------------------------|--------------------------|--------------------------|--------------------------|--------------------------|
| | G | F | E | D | C | B | A | A⁺ | A⁺⁺ | A⁺⁺⁺ |
| <input type="checkbox"/> M | <27% | ≥27% | ≥30% | ≥33% | ≥36% | ≥39% | ≥65% | ≥100% | ≥130% | ≥163% |
| <input type="checkbox"/> L | <27% | ≥27% | ≥30% | ≥34% | ≥37% | ≥50% | ≥75% | ≥115% | ≥150% | ≥188% |
| <input type="checkbox"/> XL | <27% | ≥27% | ≥30% | ≥35% | ≥38% | ≥55% | ≥80% | ≥123% | ≥160% | ≥200% |
| <input type="checkbox"/> XXL | <28% | ≥28% | ≥32% | ≥36% | ≥40% | ≥60% | ≥85% | ≥131% | ≥170% | ≥213% |

Water heating energy efficiency under colder and warmer climate conditions

Colder: ^③ - 0.2 x ^② = %

Warmer: ^③ + 0.4 x ^② = %

The energy efficiency of the package of products provided for in this fiche may not correspond to its actual energy efficiency once installed in a building, as this efficiency is influenced by further factors such as heat loss in the distribution system and the dimensioning of the products in relation to building size and characteristics.

AD-3000747-01

- I The value of the water heating energy efficiency of the combination heater, expressed in %.
- II The value of the mathematical expression $(220 \cdot Q_{ref})/Q_{nonsol}$, where Q_{ref} is taken from Regulation EU 811/2013, Annex VII Table 15 and Q_{nonsol} from the product fiche of the solar device for the declared load profile M, L, XL or XXL of the combination heater.
- III The value of the mathematical expression $(Q_{aux} \cdot 2,5)/(220 \cdot Q_{ref})$, expressed in %, where Q_{aux} is taken from the product fiche of the solar device and Q_{ref} from Regulation EU 811/2013, Annex VII Table 15 for the declared load profile M, L, XL or XXL.

Baxi Customer Support



0344 871 1545

Opening hours

Monday - Friday, 8.00am-6.00pm

Weekends and Bank Holidays, 8.30am-2.00pm

Please note calls may be recorded for training and monitoring purposes



baxi.co.uk

Register now to activate your warranty:

www.baxi.co.uk/registration

For the warranty to be maintained, please make sure...

- 1** Benchmark checklist is completed
- 2** Warranty is registered within 30 days
- 3** The boiler has an annual service

For full terms and conditions, visit www.baxi.co.uk/terms. Failure to adhere to terms and conditions will void your manufacturer's warranty.



Baxi
Brooks House,
Coventry Road,
Warwick, CV34 4LL



Please ensure the boiler is installed in accordance with these installation instructions and that you adhere to the Building Regulations.

e&oe

All descriptions and illustrations provided in this document have been carefully prepared but we reserve the right to make changes and improvements in our products which may affect the accuracy of the information contained in this leaflet. All goods are sold subject to our standard Conditions of Sale which are available on request.

CE
0086



BAXI