

# **BAXI**

## Installation & Servicing Instructions



### **Baxi Combi Instant 80e & 105e**

Gas Fired Wall Mounted Combination Boiler

## Natural Gas

---

**Baxi Combi Instant 80e**  
G.C.N° 47 075 13

**Baxi Combi Instant 105e**  
G.C.N° 47 075 09

The boiler meets the requirements of Statutory Instrument " The Boiler (Efficiency) Regulations 1993 N° 3083" and is deemed to meet the requirements of Directive 92/42/EEC on the energy efficiency requirements for new hot water boilers fired with liquid or gaseous fuels:-

Type test for purpose of Regulation 5 certified by:  
Notified Body 0051.

Product/Production certified by:  
Notified Body 0051.

For GB/IE only.

## Building Regulations and the Benchmark Commissioning Checklist

Building Regulations (England & Wales) require notification of the installation of a heating appliance to the relevant Local Authority Building Control Department. From 1 April 2005 this can be achieved via a Competent Persons Self Certification Scheme as an option to notifying the Local Authority directly. Similar arrangements will follow for Scotland and will apply in Northern Ireland from 1 January 2006.

CORGI operate a Self Certification Scheme for gas heating appliances.

These arrangements represent a change from the situation whereby compliance with Building Regulations was accepted as being demonstrated by completion of the Benchmark Logbook (which was then left on site with the customer).

With the introduction of Self Certification Schemes, the Benchmark Logbook is being withdrawn. However, a similar document in the form of a commissioning checklist and service interval record is incorporated at the back of these instructions.

Potterton is a member of the Benchmark initiative and fully supports the aims of the programme. Its aim is to improve the standards of installation and commissioning of central heating systems in the UK and to encourage the regular servicing of all central heating systems to ensure safety and efficiency.

Building Regulations require that installations should comply with manufacturer's instructions. It is therefore important that the commissioning checklist is completed by the installer. The relevant section of Building Regulations only relates to dwellings. Therefore the checklist only applies if the appliance is being installed in a dwelling or some related structure.

The flowchart opposite gives guidance for installers on the process necessary to ensure compliance with Building Regulations.



Baxi is a BS-EN ISO 9001  
Accredited Company

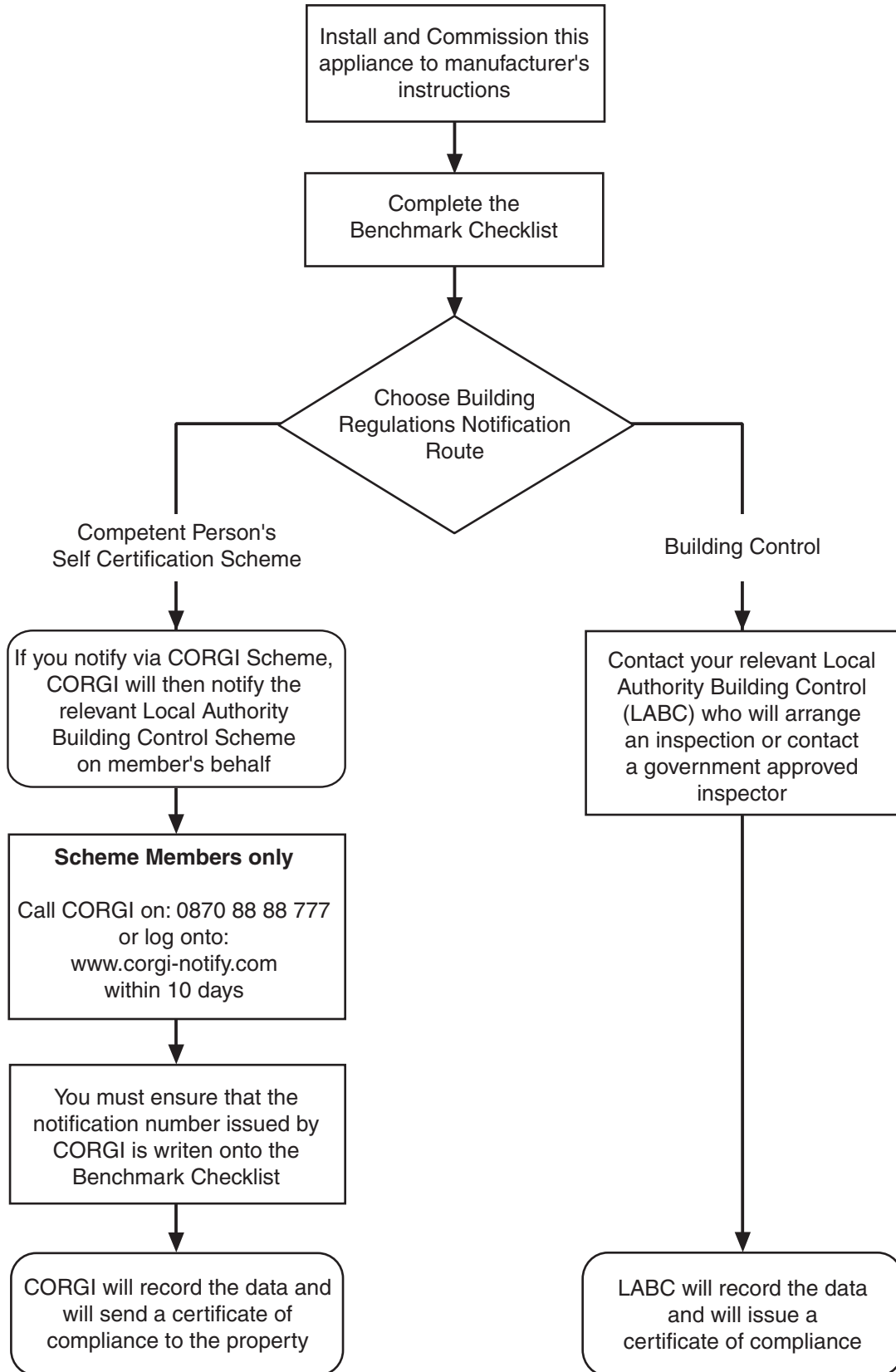

## Legislation

### IMPORTANT - Installation, Commissioning, Service & Repair

This appliance must be installed in accordance with the manufacturer's instructions and the regulations in force. Read the instructions fully before installing or using the appliance.

In GB, this must be carried out by a competent person as stated in the Gas Safety (Installation & Use) Regulations.

**Definition of competence:** A person who works for a CORGI registered company and holding current certificates in the relevant ACS modules, is deemed competent.

In IE, this must be carried out by a competent person as stated in I.S. 813 "Domestic Gas Installations".

**Lifting** - This product should be lifted and handled by two people. Stooping should be avoided and protective equipment worn where necessary. Carrying & lifting equipment should be used as required e.g. when installing in a loft space.

The addition of anything that may interfere with the normal operation of the appliance without express written permission from the manufacturer or his agent could invalidate the appliance warranty. In GB this could also infringe the Gas Safety (Installation and Use) Regulations.

**Warning** - Check the information on the data plate is compatible with local supply conditions.

**Baxi declare that no substances harmful to health are contained in the appliance or used during appliance manufacture.**

**The appliance is suitable only for installation in GB and IE and should be installed in accordance with the rules in force, and only used in a suitably ventilated location.**

In GB, the installation must be carried out by a CORGI Registered Installer. It must be carried out in accordance with the relevant requirements of the:

- Gas Safety (Installation & Use) Regulations.
- The appropriate Building Regulations either The Building Regulations, The Building Regulations (Scotland), Building Regulations (Northern Ireland).
- The Water Fittings Regulations or Water Byelaws in Scotland.
- The Current I.E.E. Wiring Regulations.

Where no specific instructions are given, reference should be made to the relevant British Standard Code of Practice.

In IE, the installation must be carried out by a competent Person and installed in accordance with the current edition of I.S. 813 'Domestic Gas Installations', the current Building Regulations and reference should be made to the current ETCl rules for electrical installation.

**All systems must be thoroughly flushed and treated with inhibitor (see section 6.2).**

### Codes of Practice, most recent version should be used

**In GB the following Codes of Practice apply:**

Standard	Scope
BS 6891	Gas Installation.
BS 5546	Installation of hot water supplies for domestic purposes.
BS 5449	Forced circulation hot water systems.
BS 6798	Installation of gas fired hot water boilers.
BS 5440 Part 1	Flues.
BS 5440 Part 2	Ventilation.
BS 7074	Expansion vessels and ancillary equipment for sealed water systems.
BS 7593	Treatment of water in domestic hot water central heating systems.

**In IE the following Codes of Practice apply:**

Standard	Scope
I.S. 813	Domestic Gas Installations.
The following BS standards give valuable additional information;	
BS 5546	Installation of hot water supplies for domestic purposes.
BS 5449	Forced circulation hot water systems.
BS 7074	Expansion vessels and ancillary equipment for sealed water systems.
BS 7593	Treatment of water in domestic hot water central heating systems.

All CORGI registered installers carry a CORGI identification card and have a registration number. You can check your installer is registered by telephoning 0870 4012300 or writing to:-

I Elmwood,  
Chineham Business Park,  
Crockford Lane,  
Basingstoke. RG24 8WG

or check online at [www.corgi-gas-safety.com](http://www.corgi-gas-safety.com)

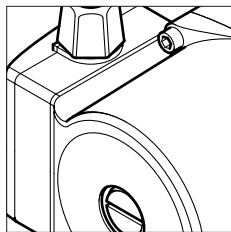
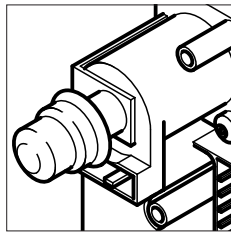
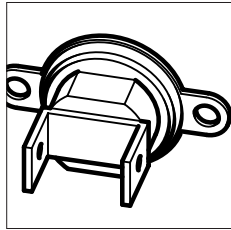

## Contents

Section	Page
1.0 Introduction	6
2.0 General Layout	7
3.0 Appliance Operation	8
4.0 Technical Data	10
5.0 Dimensions and Fixings	12
6.0 System Details	13
7.0 Site Requirements	16
8.0 Installation	21
9.0 Commissioning the Boiler	26
10.0 Completion	28
11.0 Servicing the Boiler	29
12.0 Changing Components	31
13.0 Illustrated Wiring Diagram	40
14.0 Fault Finding	41
15.0 Short Parts List	48
Benchmark Checklist	50

## 1.0 Introduction

### 1.1 Description

1. The Baxi Combi Instant 80e or 105e is a fully automatic gas fired wall mounted combination boiler. It is room sealed and fan assisted, and will serve central heating and mains fed domestic hot water.
2. The unit incorporates a small storage cylinder built into the boiler providing hot water the moment the tap is turned on.
3. The boiler is set to give a maximum output of 24.0 kW (Instant 80e) or 31.0 kW (Instant 105e).
4. It is designed for use on Natural Gas (G20) and can be converted to use Propane (Instant 80e and 105e) or Butane (Instant 80e only).
5. The boiler is suitable for use only on fully pumped sealed heating systems. Priority is given to domestic hot water.
6. The boiler data badge gives details of the model, serial number and Gas Council number and is situated on the control box. It is visible when the case front panel is removed (Fig. 1).
7. The boiler is intended to be installed in residential / commercial / light industrial E.M.C. environments on a governed meter supply only.
8. The boiler must be installed with one of the purpose designed flues such as the standard horizontal flue kit, part no. 247719.
9. **All systems must be thoroughly flushed and treated with inhibitor (see section 6.2).**

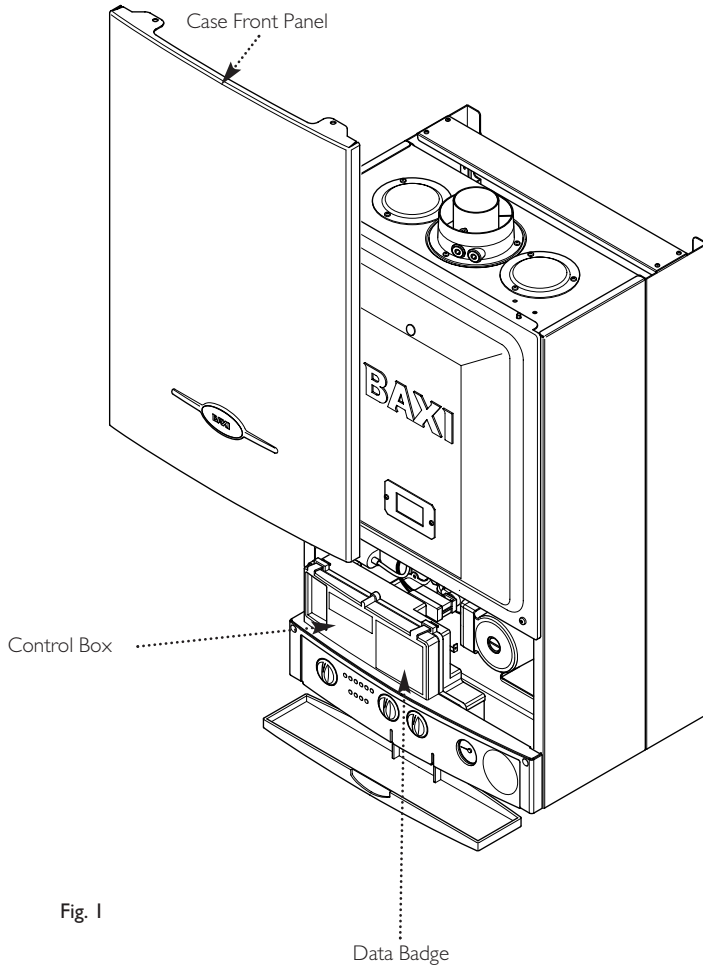

Fig. 1

### 1.2 Instant Domestic Hot Water

(Expansion Vessel & Pre-Heat Store)

1. The boiler expansion vessel incorporates a small volume of stored primary hot water.
2. When the boiler has been off and there is then a demand for domestic hot water the stored primary hot water ensures that domestic hot water is supplied instantly at temperature.
3. The stored hot water is part of the primary circuit. This is not supplied as domestic hot water, which is fresh mains water heated by a heat exchanger within the boiler.
4. The stored primary hot water temperature is maintained whilst the boiler is in operation. During a period when there is no demand for heating or hot water the temperature of the stored primary hot water will eventually fall. The boiler will operate occasionally in order to maintain the temperature. This is indicated by the domestic hot water mode neon flashing.

### 1.3 Optional Extras

Various flue extensions, bends, vertical flue kits, control accessories etc. are available as optional extras. These are detailed in a separate publication.

## 2.0 General Layout

### 2.1 Layout

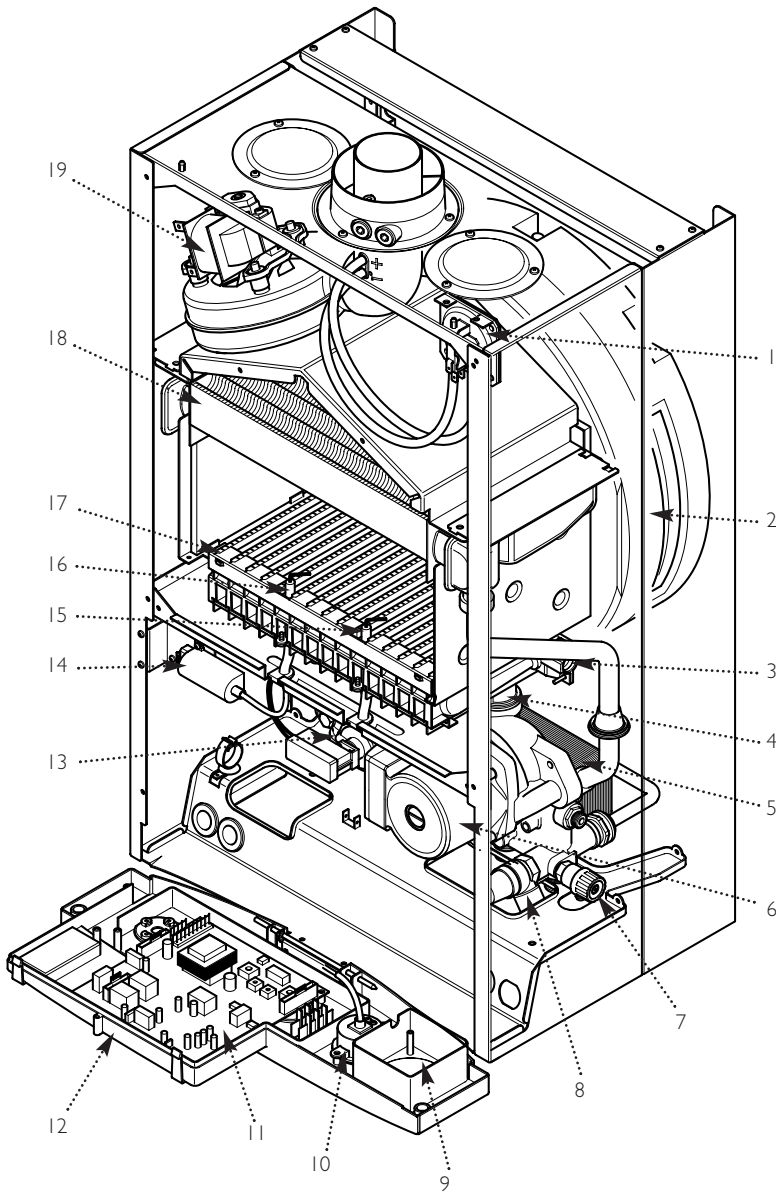

1. Air Pressure Switch
2. Expansion Vessel & Pre-Heat Store
3. Burner Manifold
4. Automatic Air Vent
5. DHW Plate Heat Exchanger
6. Circulation Pump
7. Drain Off Point
8. Pressure Relief Valve
9. Position for Optional Integral Timer
10. Central Heating System Pressure Gauge
11. PCB
12. Control Box
13. 3-Way Valve Assembly
14. Spark Generator
15. Flame Sensing Electrode
16. Spark Electrode
17. Burner
18. Primary Heat Exchanger
19. Fan Assembly
20. On/Off/Reset Selector Switch
21. Central Heating Temperature Control
22. Domestic Hot Water Pre-Heat Control
23. Flame Failure
24. Safety Thermostat
25. Fault on Fan or Flue
26. Fault on Pump or Low System Pressure
27. Fault on Hot Water Sensor
28. Fault on Central Heating Sensor
29. Power On
30. Domestic Hot Water Mode
31. Central Heating Mode
32. Burner On

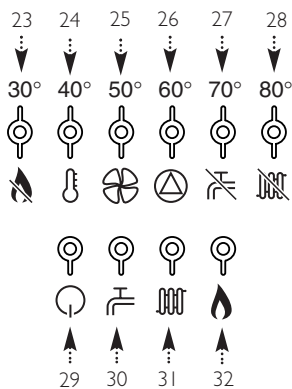

When neons 23 to 28 are constantly illuminated, they indicate the temperature of the central heating water.

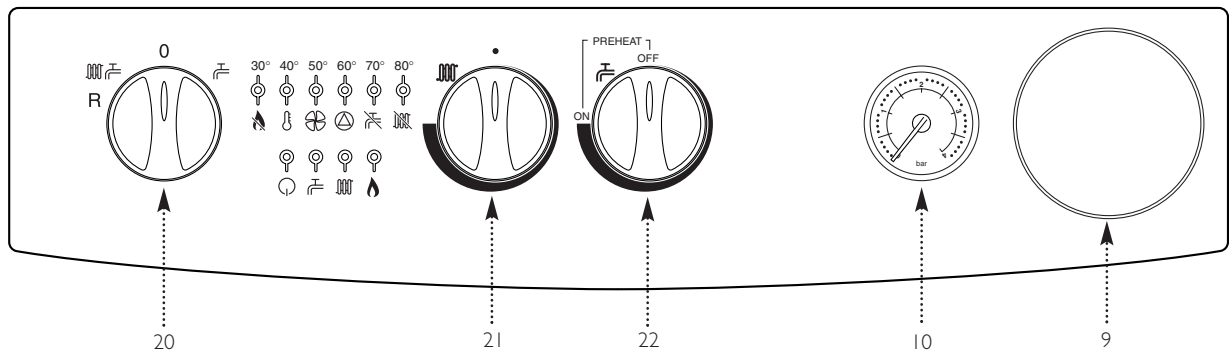

## Central Heating Mode

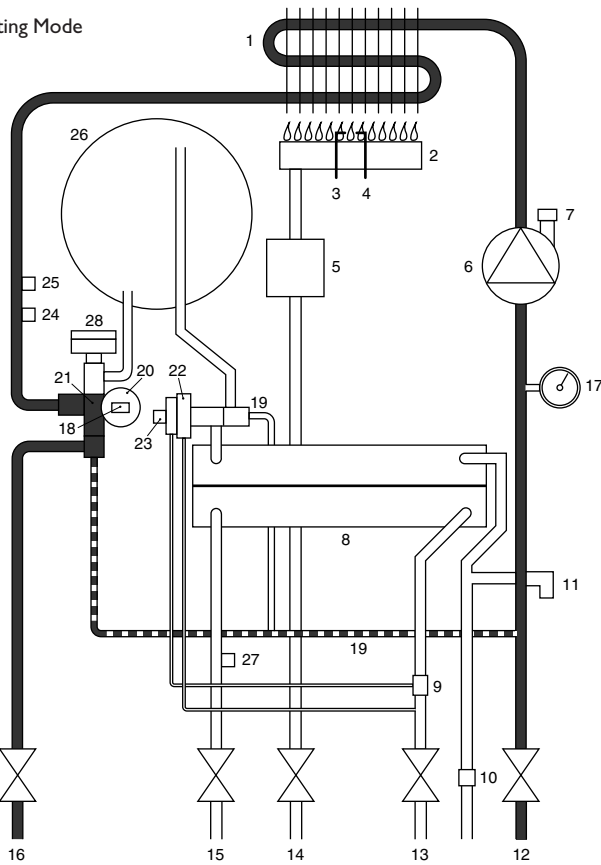

Fig. 2

### Key

- |   |   |
|---|---|
| 1 Primary Heat Exchanger                    | 14 Gas Inlet                                    |
| 2 Burner                                    | 15 Domestic Hot Water Outlet                    |
| 3 Ignition Electrode                        | 16 Heating Flow                                 |
| 4 Flame Sensing Electrode                   | 17 Pressure Gauge                               |
| 5 Gas Valve                                 | 18 Hydraulic Pressure Sensor Microswitch        |
| 6 Pump                                      | 19 Automatic By-Pass                            |
| 7 Automatic Air Vent                        | 20 Hydraulic Pressure Sensor                    |
| 8 Plate Heat Exchanger                      | 21 Diverter Valve Assembly                      |
| 9 Flow Sensor with Filter                   | 22 Domestic Hot Water Flow Priority Assembly    |
| 10 Pressure Relief Valve                    | 23 Domestic Hot Water Flow Priority Microswitch |
| 11 Boiler Drain Point                       | 24 Safety Thermostat                            |
| 12 Heating Return                           | 25 Central Heating Temperature Sensor           |
| 13 Cold Water Inlet On/Off Valve and Filter | 26 Expansion Vessel & Pre-Heat Store            |
|   | 27 Domestic Hot Water Temperature Sensor        |

## Domestic Hot Water - Preheat Mode

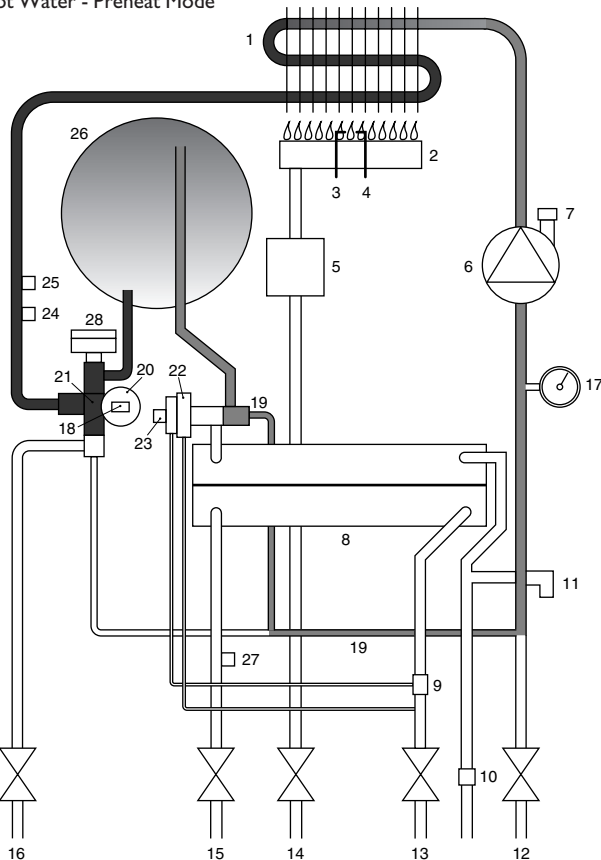

Fig. 3

## 3.0 Appliance Operation

**NOTE:** All delay timers mentioned in 3.1 and 3.2 are overridden by domestic hot water demand.

### 3.1 Central Heating Mode (Fig. 2)

1. With a demand for heating, the pump circulates water through the primary circuit. At a pre-determined flow rate the central heating flow switch operates, initiating the ignition sequence.

2. The main burner ignites at low rate, then the gas valve controls the gas rate to maintain the heating temperature measured by the temperature sensor.

3. When the flow temperature exceeds the setting temperature, a 3 minute delay occurs before the burner relights automatically (anti-cycling). The pump continues to run during this period.

4. When the demand is satisfied the burner is extinguished and the pump continues to run for a period of 30 minutes (Pump Overrun).

5. If there is no other demand the pre-heat function will operate if switched on (see Section 3.2).

### 3.2 Domestic Hot Water - Preheat Mode (Fig. 3)

1. With the pre-heat function switched on (pre-heat control fully clockwise), priority is given to the replenishment of the pre-heat store. The DHW mode neon ( $\text{H}_2\text{O}$ ) will flash during this function.

2. The diverter valve remains in the DHW priority position. This allows the pump to circulate hot water to the store and back to the primary heat exchanger via the bypass pipe.

3. The automatic ignition sequence commences after approximately 25 seconds and the burner will light.

4. When the store reaches the desired temperature the burner is extinguished. The pump continues to run for a period of 30 seconds.

5. Following a demand for domestic hot water or the end of a central heating ON period, the pre-heat function restarts.



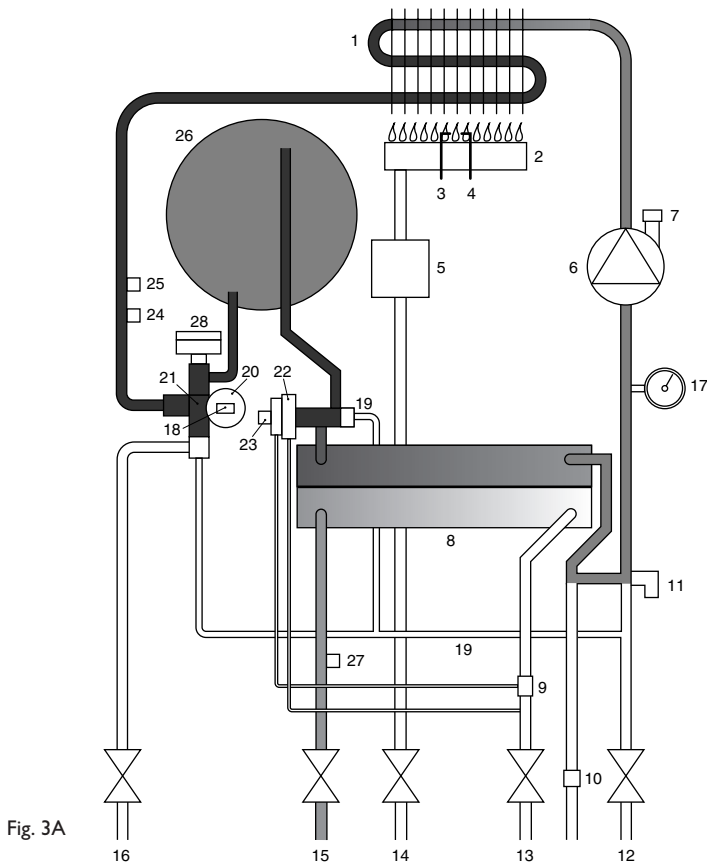

Fig. 3A

Key

- |   |   |
|---|---|
| 1 Primary Heat Exchanger                    | 14 Gas Inlet                                    |
| 2 Burner                                    | 15 Domestic Hot Water Outlet                    |
| 3 Ignition Electrode                        | 16 Heating Flow                                 |
| 4 Flame Sensing Electrode                   | 17 Pressure Gauge                               |
| 5 Gas Valve                                 | 18 Hydraulic Pressure Sensor Microswitch        |
| 6 Pump                                      | 19 Automatic By-Pass                            |
| 7 Automatic Air Vent                        | 20 Hydraulic Pressure Sensor                    |
| 8 Plate Heat Exchanger                      | 21 Diverter Valve Assembly                      |
| 9 Flow Sensor with Filter                   | 22 Domestic Hot Water Priority Assembly         |
| 10 Pressure Relief Valve                    | 23 Domestic Hot Water Flow Priority Microswitch |
| 11 Boiler Drain Point                       | 24 Safety Thermostat                            |
| 12 Heating Return                           | 25 Central Heating Temperature Sensor           |
| 13 Cold Water Inlet On/Off Valve and Filter | 26 Expansion Vessel & Pre-Heat Store            |
|   | 27 Domestic Hot Water Temperature Sensor        |

## 3.0 Appliance Operation

### 3.3 Domestic Hot Water Mode (Fig. 3A)

1. Priority is given to the domestic hot water supply. A demand at a tap or shower will override any central heating requirement.

2. The flow of water will operate the DHW flow switch which requests the 3 way valve to change position. This will allow the pump to circulate the primary water through the DHW plate heat exchanger and take the stored water to give instant hot water.

3. The burner will light automatically and the temperature of the domestic hot water is controlled by the temperature sensor.

4. When the domestic hot water demand ceases the burner will extinguish and the diverter valve will remain in the domestic hot water mode, unless there is a demand for central heating.

5. If there is no other demand the pre-heat function will operate if switched on (see Section 3.2)

**IMPORTANT:** When the selector switch is in the '0' (Off) position the electrical supply to the boiler is isolated. The boiler will not operate and the integral timer (if fitted) will require resetting once the selector switch is set to either Position (i) or Position (ii).

### 3.4 Frost Protection Mode

1. The frost protection mode is integral to the appliance and functions only with the selector switch (see Section 2.1) in the domestic hot water and central heating position. If the system temperature falls below 5° C then the boiler will fire on its minimum setting until a flow temperature of 30° C is reached. Further protection can be incorporated by using a system frost thermostat.

### 3.5 Pump Protection

1. With the selector switch (see Section 2.1) in either the central heating or central heating and hot water position the pump will automatically operate for 1 minute in every 24 hours to prevent sticking.

## 4.2 Combi Instant 80e

<b>Appliance Type</b>	C <sub>12</sub>	C <sub>32</sub>
<b>Appliance Category</b>	CAT II 2H 3+	
<b>Heat Input C/H &amp; DHW (Net)</b>		
	Max	Min
kW	26.3	10.6
Btu/h	89,739	36,168
<b>Heat Output</b>		
	Max	Min
kW	24.0	9.3
Btu/h	81,819	31,738
<b>Max Gas Rate</b> (Natural Gas - G20) (After 10 Mins)		
m <sup>3</sup> /h	2.78	
ft <sup>3</sup> /h	98.12	
<b>Burner Pressure</b> (Natural Gas - G20)		
	Max Rate	Min Rate
mbar	12.2 ± 0.5	2.5 ± 0.2
in wg	4.88 ± 0.2	1.0 ± 0.2
<b>Inlet Pressure</b> (Natural Gas - G20)		
mbar	20	
in wg	8	
<b>Burner Injector</b> (Natural Gas - G20) 12 x 1.28mm Diameter		
<b>Electrical Supply</b> 230V~ 50Hz (Appliance must be connected to an earthed supply)		
<b>Power Consumption</b> 170W		
<b>External Fuse Rating</b> 3A		
<b>Internal Fuse Rating</b> Fuse 2A Fast Blow to BS 4265		
<b>Electrical Protection</b> IPX5D		

<b>NO<sub>x</sub> Class</b>	3	
<b>Flue Terminal Dimensions</b>	Diameter	100mm
	Projection	95mm
<b>Connections</b>		
	copper tails	
Gas Supply	-	22mm
Central Heating Flow	-	22mm
Central Heating Return	-	22mm
Cold Water Mains Inlet	-	15mm
DHW Flow	-	15mm
Pressure Relief Discharge	-	15mm
<b>Outercase Dimensions</b>		
Casing Height	-	780mm
Overall Height Inc Flue		
Elbow	-	980mm
Casing Width	-	450mm
Casing Depth	-	345mm
<b>Clearances</b>		
Both Sides	5 mm Min	
Above Casing	200 mm Min	
Below Casing	200 mm Min	
Front	450 mm Min (For Servicing)	
Front	5 mm Min (In Operation)	
<b>Weights</b>		
	kg	
Packaged Boiler Carton	48.5	
Packaged Flue Kit	3	
Installation Lift Weight	42	
<b>Central Heating Primary Circuit Pressures</b>		
	bar	
Safety Discharge	3	
Max Operating	2.5	
Min Operating	0.5	
Recommend Operating	1-2	

<b>DHW Circuit Pressures</b>	bar
Max Operating	8
Min Operating	0.2
Min Operating Pressure at 12.7 l/min	0.96
<b>Flow Rates</b> l/min	
DHW Flow Rate @ 30°C Rise	13.7
DHW Flow Rate @ 35°C Rise	9.8
Min Working DHW Flow Rate	2.5
<b>Pump - Grundfos UP 15-50</b> Available Head See graph below	
<b>Expansion Vessel</b> - (For Central Heating only). Integral with appliance)	
	bar
Min Pre-charge Pressure	0.5
	litre
Max Capacity of CH System	80
Primary Water Content of Boiler (unpressurised)	3.0
<b>Temperatures</b>	
C.H. Flow Temp (adjustable)	35°C to 85°C max (± 5°C)
D.H.W. Flow Temp	35°C to 65°C max (± 5°C) dependent upon flow rate 50°C Pre-heat OFF 65°C Pre-heat ON ± 5°C dependent upon flow rate

### SEDBUK Declaration For Combi Instant 80e

The seasonal efficiency (SEDBUK) is 78.6 %

This value is used in the UK Government's Standard Assessment Procedure (SAP) for energy rating of dwellings. The test data from which it has been calculated have been certified by 0051.

<b>LPG Gases Propane - G31 and Butane - G30</b>		
<b>Burner Injector</b> 12 x 0.77mm diameter		
<b>Burner Pressure</b>	Max Rate	Min Rate
Propane	36.2	6.4
	in wg	2.6
Butane	28.3	5.3
	in wg	2.1
<b>Inlet Pressures</b>	Propane	Butane
mbar	37	28
in wg	14.8	11.2

Pump - Available Head

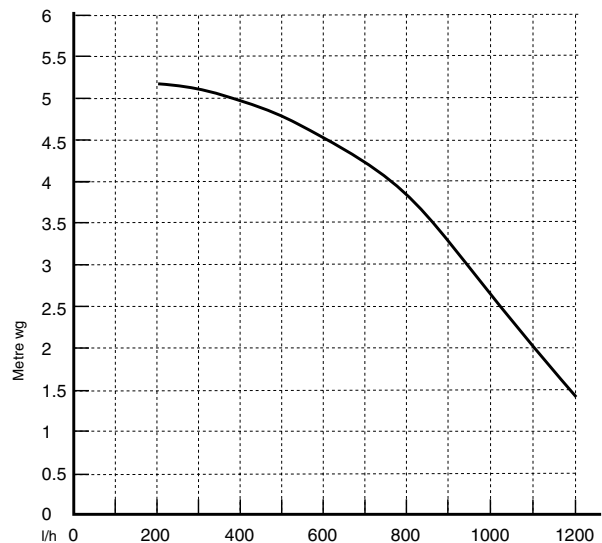

## 4.0 Technical Data

### 4.2 Combi Instant 105e

<b>Appliance Type</b>	C <sub>12</sub>	C <sub>32</sub>
<b>Appliance Category</b>	CAT II 2H 3P	
<b>Heat Input C/H &amp; DHW (Net)</b>		
	Max	Min
kW	34.3	11.9
Btu/h	117,036	40,610
<b>Heat Output</b>		
	Max	Min
kW	31.0	10.4
Btu/h	105,776	35,490
<b>Max Gas Rate</b>	(Natural Gas - G20) (After 10 Mins)	
m <sup>3</sup> /h	3.63	
ft <sup>3</sup> /h	128.12	
<b>Burner Pressure</b>	(Natural Gas - G20)	
	Max Rate	Min Rate
mbar	13.4 ± 0.5	1.8 ± 0.2
in wg	5.36 ± 0.2	0.72 ± 0.2
<b>Inlet Pressure</b>	(Natural Gas - G20)	
mbar	20	
in wg	8	
<b>Burner Injector</b>	(Natural Gas - G20) 15 x 1.28mm Diameter	
<b>Electrical Supply</b>	230V~ 50Hz (Appliance must be connected to an earthed supply)	
<b>Power Consumption</b>	190W	
<b>External Fuse Rating</b>	3A	
<b>Internal Fuse Rating</b>	Fuse 2A Fast Blow to BS 4265	
<b>Electrical Protection</b>	IPX5D	

<b>NO<sub>x</sub> Class</b>	3	
<b>Flue Terminal Dimensions</b>	Diameter	100mm
	Projection	95mm
<b>Connections</b>		
	copper tails	
Gas Supply	-	22mm
Central Heating Flow	-	22mm
Central Heating Return	-	22mm
Cold Water Mains Inlet	-	15mm
DHW Flow	-	15mm
Pressure Relief Discharge	-	15mm
<b>Outer Case Dimensions</b>		
Casing Height	-	780mm
Overall Height Inc Flue	-	
Elbow	-	980mm
Casing Width	-	450mm
Casing Depth	-	345mm
<b>Clearances</b>		
Both Sides	5 mm Min	
Above Casing	200 mm Min	
Below Casing	200 mm Min	
Front	450 mm Min (For Servicing)	
Front	5 mm Min (In Operation)	
<b>Weights</b>		
	kg	
Packaged Boiler Carton	50.5	
Packaged Flue Kit	3	
Installation Lift Weight	44	
<b>Central Heating Primary Circuit Pressures</b>		
	bar	
Safety Discharge	3	
Max Operating	2.5	
Min Operating	0.5	
Recommend Operating	1-2	

<b>DHW Circuit Pressures</b>	bar
Max Operating	8
Min Operating	0.2
Min Operating Pressure at 12.7 l/min	0.96
<b>Flow Rates</b>	
	l/min
DHW Flow Rate @ 30°C Rise	14.7
DHW Flow Rate @ 35°C Rise	12.7
Min Working DHW Flow Rate	2.5
<b>Pump - Grundfos UP 15-60</b>	
Available Head	See graph below
<b>Expansion Vessel</b> - (For Central Heating only. Integral with appliance)	
	bar
Min Pre-charge Pressure	0.5
	litre
Max Capacity of CH System	80
Primary Water Content of Boiler (unpressurised)	3.2
<b>Temperatures</b>	
C.H. Flow Temp (adjustable)	35°C to 85°C max (± 5°C)
D.H.W. Flow Temp	35°C to 65°C max (± 5°C) dependent upon flow rate 50°C Pre-heat OFF 65°C Pre-heat ON ± 5°C dependent upon flow rate

#### SEDBUK Declaration For Combi Instant 105e

The seasonal efficiency (SEDBUK) is 78.5 %

This value is used in the UK Government's Standard Assessment Procedure (SAP) for energy rating of dwellings. The test data from which it has been calculated have been certified by 0051.

<b>LPG Gases Propane - G31</b>			
<b>Burner Injector</b> 15 x 0.77mm diameter			
<b>Burner Pressure</b>		Max Rate	Min Rate
Propane	mbar	35.8 ± 0.5	4.9 ± 0.2
	in wg	14.3 ± 0.2	2 ± 0.2
<b>Inlet Pressures</b>			
	mbar	37	
	in wg	14.8	

Pump - Available Head

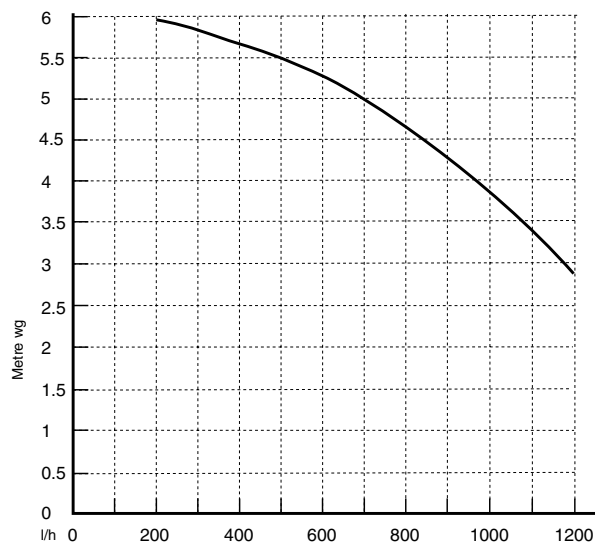

## 5.0 Dimensions and Fixings

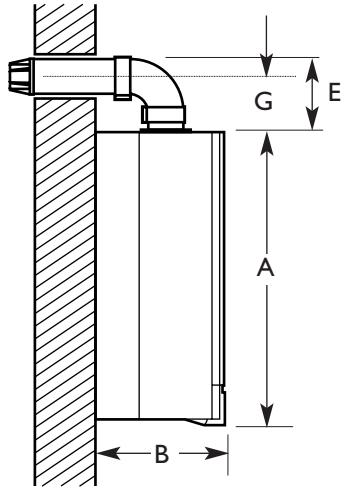

### Dimensions

A	780mm
B	345mm
C	450mm
D	107mm Ø Min.
E	200mm
F	190mm
G	143mm

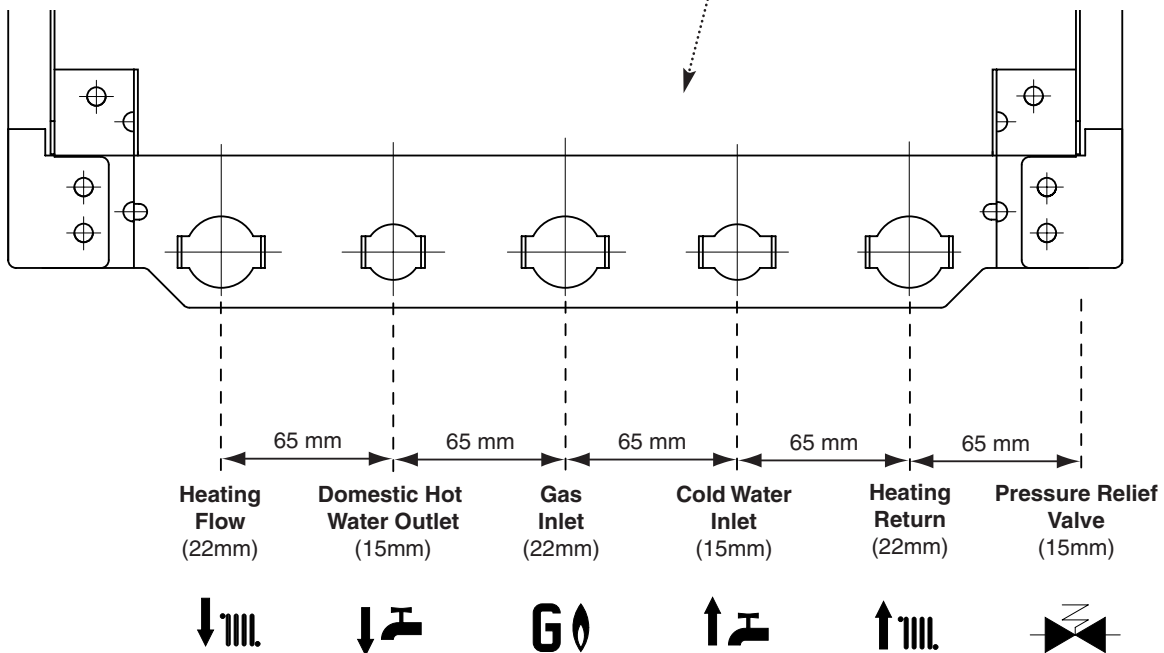
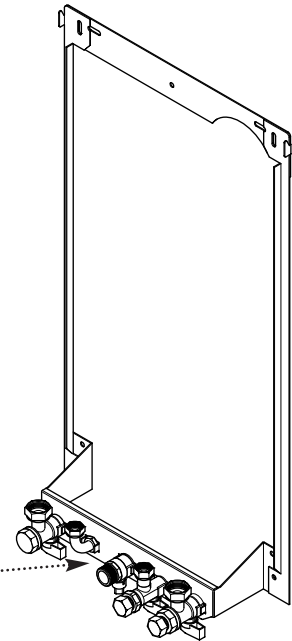
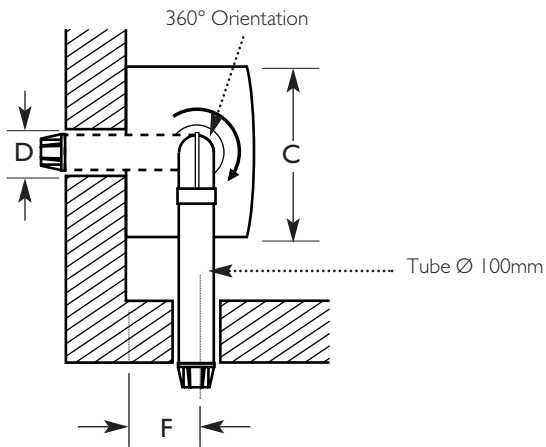

## 6.0 System Details

### 6.1 Information

1. The Baxi Combi Instant 80e and 105e Combination Boilers are 'Water Byelaws Scheme - Approved Products'.

To comply with the Water Byelaws your attention is drawn to the following installation requirements and notes (IRN).

- a) IRN 001 - See text of entry for installation requirements and notes.
- b) IRN 116 - Byelaw 90 and 91.
- c) IRN 302 - Byelaw 14.

2. Reference to the WRc publications, 'Water fittings and materials directory' and 'Water supply byelaws guide' give full details of byelaws and the IRNs.

### 6.2 Central Heating Circuit

1. The appliance is suitable for fully pumped SEALED SYSTEMS ONLY.

#### Treatment of Water Circulating Systems

- All recirculatory water systems will be subject to corrosion unless an appropriate water treatment is applied. This means that the efficiency of the system will deteriorate as corrosion sludge accumulates within the system, risking damage to pump and valves, boiler noise and circulation problems.
- For optimum performance after installation this boiler and its associated central heating system must be flushed. A means of achieving this is by following the guidelines given in BS 7593 "Treatment of water in domestic hot water central heating systems".
- This must involve the use of a proprietary cleanser, such as BetzDearborn Sentinel X300 or X400, or Fernox Superfloc. Full instructions are supplied with the products, but for immediate information please contact BetzDearborn (+44 (0)151 420 9563) or Fernox (+44 (0)1799 550 811) directly.
- For long term protection against corrosion and scale, after flushing it is recommended that an inhibitor such as BetzDearborn Sentinel X100, or Fernox MB-1 or Copa used. The correct dosing is obtained by following the guidelines given in BS 7593.

**Failure to flush and add inhibitor to the system may invalidate the appliance warranty.**

- It is important to check the inhibitor concentration after installation, system modification and at every service in accordance with the inhibitor manufacturer's instructions. (Test kits are available from inhibitor stockists.)
- For information or advice regarding any of the above contact the Technical Enquiries.

### 6.3 Bypass

1. The boiler is fitted with an automatic integral bypass.

### 6.4 System Control

1. The boiler is designed for use in a heating system that incorporates external controls, i.e. a minimum of a timer device.

2. Suitable timer kits are available as optional extras.

3. For optimum operating conditions and maximum economy the fitting of a programmable room thermostat, such as the Baxi Combi Controller, is recommended.

## 6.0 System Details

### 6.5 System Filling and Pressurising

1. A filling point connection on the central heating return pipework must be provided to facilitate initial filling and pressurising and also any subsequent water loss replacement/refilling.

2. There are connection points on the mains cold water inlet and central heating return isolating taps (Fig. 4a) to which the optional filling loop kit (Part No. 248221) can be assembled.

3. The filling method adopted must be in accordance with all relevant water supply regulations and use approved equipment.

4. Your attention is drawn to: for GB: Guidance G24.2 and recommendation R24.2 of Water Regulations Guide. for IE: the current edition of I.S. 813 "Domestic Gas Installations".

5. The sealed primary circuits may be filled or replenished by means of a temporary connection between the circuit and a supply pipe, provided a 'Listed' double check valve or some other no less effective backflow prevention device is permanently connected at the inlet to the circuit and the temporary connection is removed after use.

### 6.6 Expansion Vessel (Central Heating only)

1. The appliance expansion vessel is pre-charged to 0.5 bar. Therefore, the minimum cold fill pressure is 0.5 bar. The vessel is suitable for correct operation for system capacities up to 80 litres. For greater system capacities an additional expansion vessel must be fitted - refer to BS 7074 Pt 1.

### 6.7 Pressure Relief Valve (Fig. 5)

1. The pressure relief valve is set at 3 bar, therefore all pipework, fittings, etc. should be suitable for pressures in excess of 3 bar.

2. The pressure relief discharge pipe should be not less than 15mm dia, run continuously downward, and discharge outside the building, preferably over a drain. It should be routed in such a manner that no hazard occurs to occupants or causes damage to wiring or electrical components. The end of the pipe should terminate facing down and towards the wall.

3. The discharge must not be above a window, entrance or other public access. Consideration must be given to the possibility that boiling water/steam could discharge from the pipe.

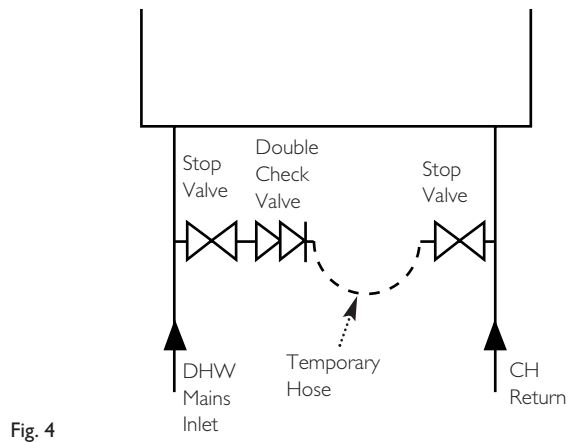

Fig. 4

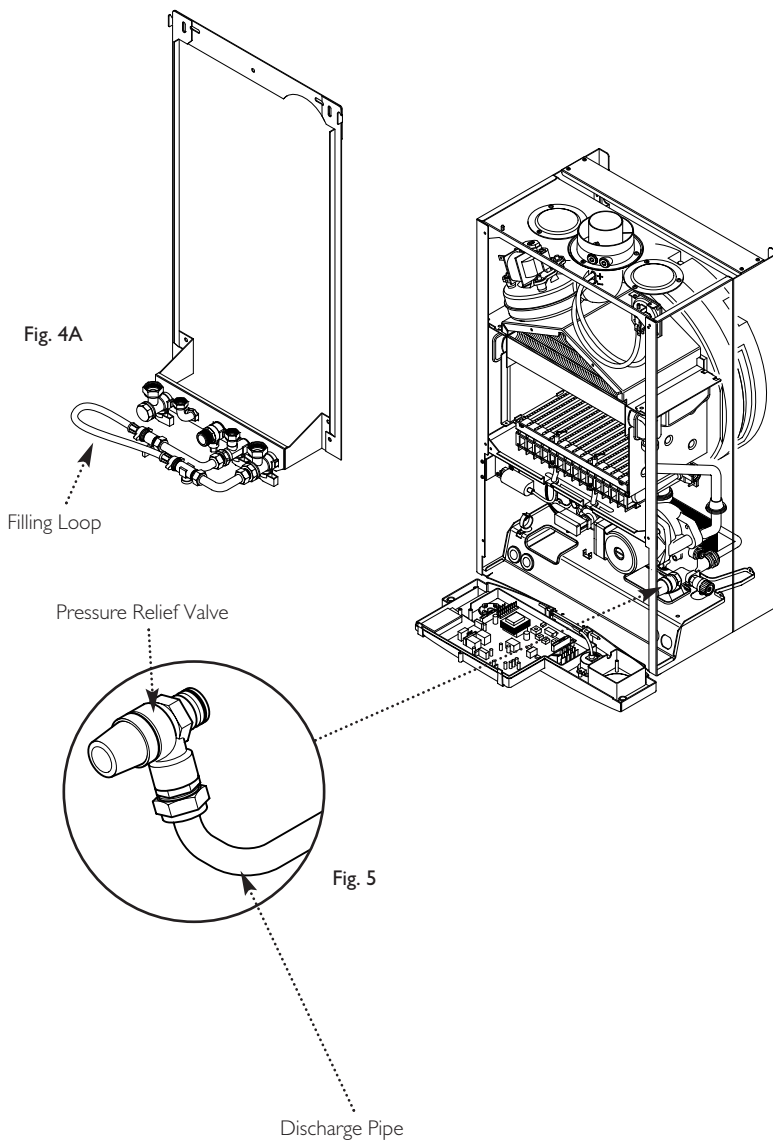

Fig. 4A

Fig. 5

## 6.0 System Details

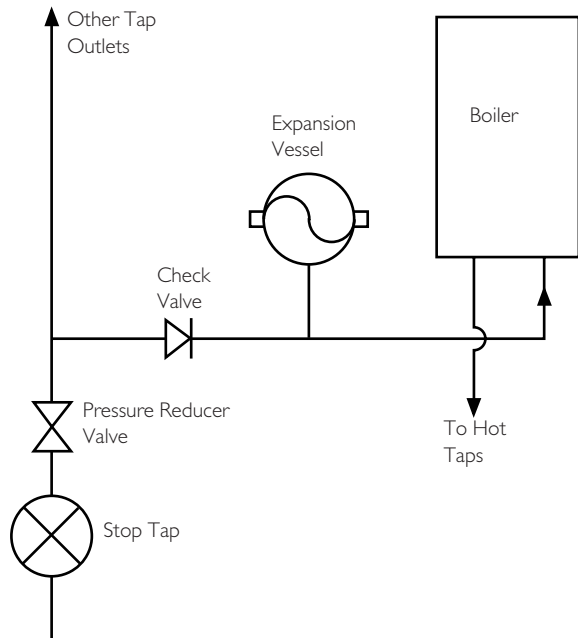

Fig. 6

### 6.8 Domestic Hot Water Circuit (Fig. 6)

1. All DHW circuits, connections, fittings, etc. should be fully in accordance with relevant standards, the water supply regulations.

2. Your attention is drawn to: for GB: Guidance G17 to G24 and recommendation R17 to R24 of the Water Regulations Guide. for IE: the current edition of I.S. 813 "Domestic Gas Installations".

3. A single check valve must be fitted as shown in Fig. 6 to prevent backflow to the supply pipe and to ensure the efficient operation of the expansion vessel which is required to accommodate the thermal expansion of the water.

4. When the domestic water system includes any device which prevents water expanding back towards the supply (check valve, loose jumpered stopcock, water meter, water treatment device), then an expansion vessel must be fitted (e.g. Zilmet 160ml, R1/2 15bar).

5. If the hot water expansion is not provided for, then high pressures can develop which may result in damage to fittings and devices on the system.

5. The boiler's maximum working mains pressure is 8 bar, therefore all pipework, connections, fittings, etc. should be suitable for pressures in excess of 8 bar. A pressure reducing valve must be fitted for pressures in excess of 8 bar. The manufacturer of any outlet fittings, such as a shower valve, may require a lower maximum pressure. The pressure reduction must take account of all fittings connected to the DHW system.

### 6.9 Showers

1. If a shower control is supplied from the appliance it should be of the thermostatic or pressure balanced type. Thermostatic type shower valves provide the best comfort and guard against water at too high a temperature. Existing controls may not be suitable - refer to the shower valve manufacturer.

### 6.10 Hard Water Areas

1. If the area of the installation is recognised as a HARD WATER AREA then a suitable device should be fitted to treat the mains water supply to the boiler.

## 7.0 Site Requirements

### 7.1 Location

1. The boiler may be fitted to any suitable wall with the flue passing through an outside wall or roof and discharging to atmosphere in a position permitting satisfactory removal of combustion products and providing an adequate air supply. The boiler should be fitted within the building unless otherwise protected by a suitable enclosure i.e. garage or outhouse. (The boiler may be fitted inside a cupboard-see Section 7.3).

2. If the boiler is sited in an unheated enclosure then it is recommended to leave the ON/OFF Selector Switch in the domestic hot water and central heating position to give frost protection.

3. If the boiler is fitted in a room containing a bath or shower reference must be made to the relevant requirements.

In GB this is the current I.E.E. Wiring Regulations and Building Regulations.

In IE reference should be made to the current edition of I.S. 813 "Domestic Gas Installations" and the current ETCl rules.

4. If the boiler is to be fitted into a building of timber frame construction then reference must be made to the current edition of Institute of Gas Engineers Publication IGE/UP/7 (Gas Installations in Timber Framed Housing).

### 7.2 Clearances (Figs. 7 & 8)

1. A flat vertical area is required for the installation of the boiler.

2. These dimensions include the necessary clearances around the boiler for case removal, spanner access and air movement. Additional clearances may be required for the passage of pipes around local obstructions such as joists running parallel to the front face of the boiler.

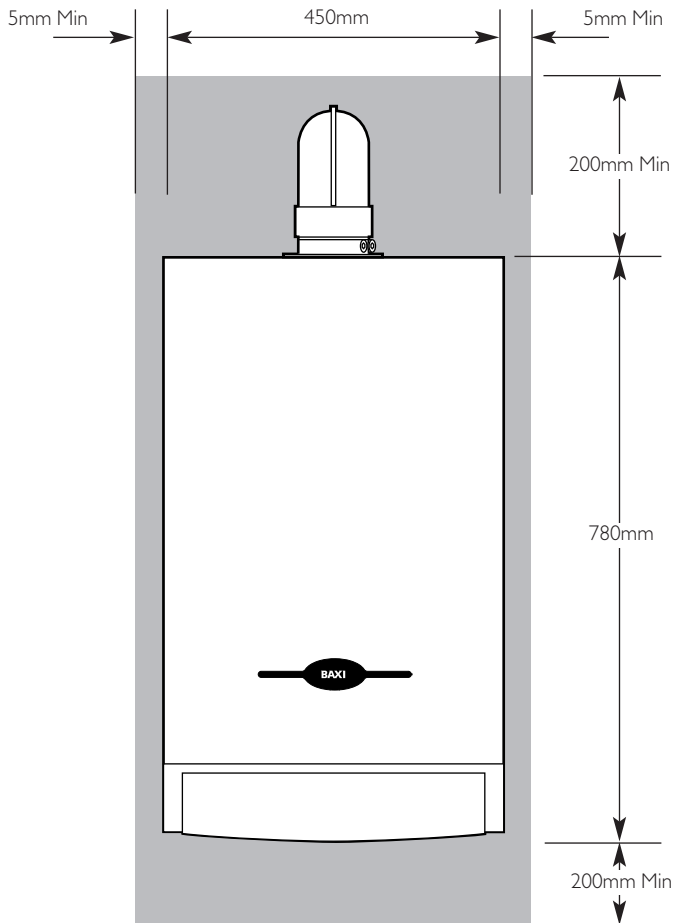

Fig. 7

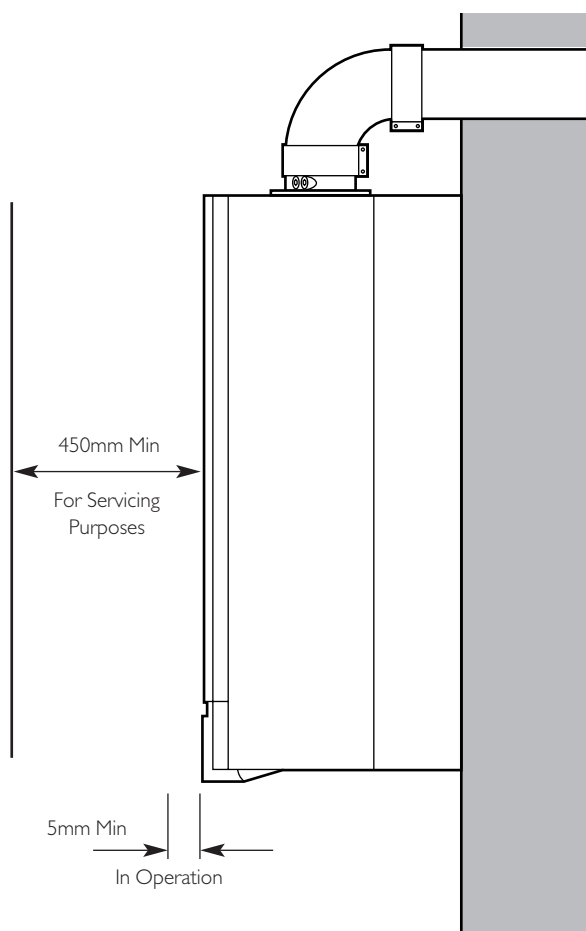

Fig. 8



## 7.0 Site Requirements

### 7.3 Ventilation of Compartments

1. Where the appliance is installed in a cupboard or compartment, no air vents are required as the appliance will run sufficiently cool without ventilation.

### 7.4 Gas Supply

1. The gas installation should be in accordance with the relevant standards. In GB this is BS 6891. In IE this is the current edition of I.S. 813 "Domestic Gas Installations".

2. The connection to the appliance is a 22mm copper tail located at the rear of the gas service cock (Fig. 9).

3. Ensure that the pipework from the meter to the appliance is of adequate size. **Do not use pipes of a smaller diameter than the boiler gas connection (22mm).**

### 7.5 Electrical Supply

1. External wiring must be correctly earthed, polarised and in accordance with the relevant regulations/rules. In GB this is the current I.E.E. Wiring Regulations. In IE reference should be made to the current edition of the ETCI rules.

2. The mains supply is 230V ~ 50Hz fused at 3A.

**NOTE:** The method of connection to the electricity supply must facilitate complete electrical isolation of the appliance.

Connection may be via a fused double-pole isolator with a contact separation of at least 3mm in all poles and servicing the boiler and system controls only.

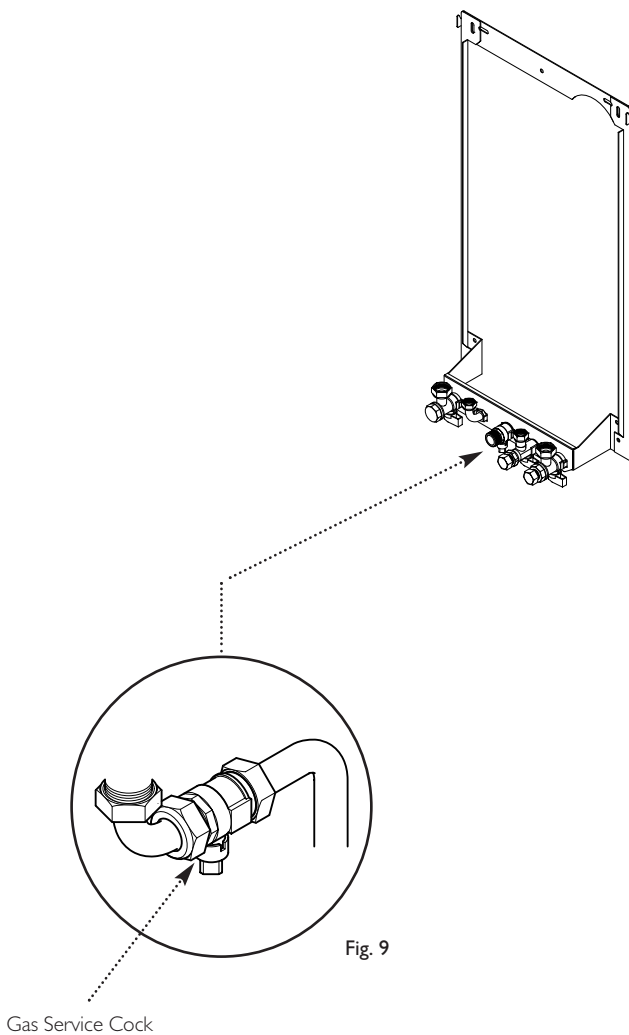

## 7.0 Site Requirements

### 7.6 Flue

1. The following guidelines indicate the general requirements for siting flue terminals.  
For GB recommendations are given in BS 5440 Pt. I.  
For IE recommendations are given in the current edition of I.S. 813 "Domestic Gas Installations".

2. If the terminal discharges onto a pathway or passageway, check that combustion products will not cause a nuisance and that the terminal will not obstruct the passageway.

3. If a terminal is less than 2 metres above a balcony, above ground or above a flat roof to which people have access, then a suitable terminal guard must be provided.

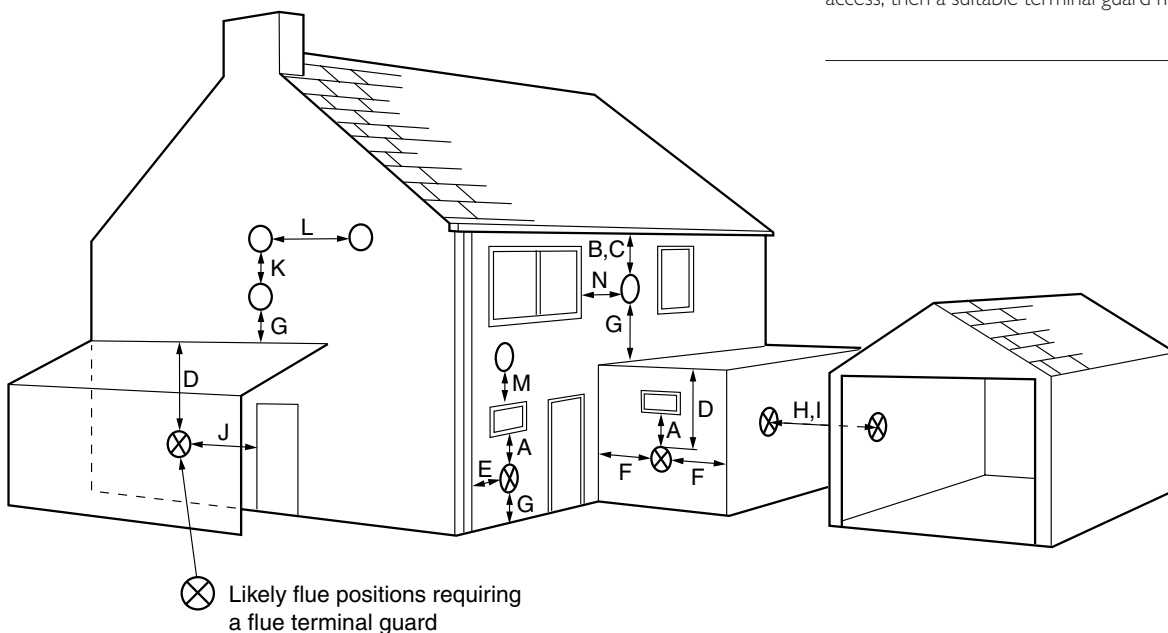
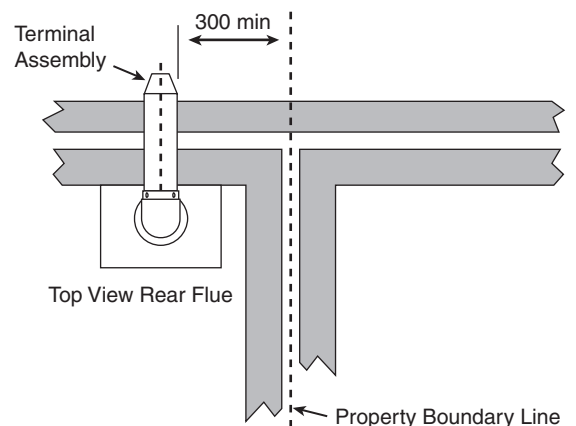

Fig. 11

#### Terminal Position with Minimum Distance (Fig. 11) (mm)

A <sup>1</sup> Directly below an openable window, air vent or any other ventilation opening.	300
B Below gutter, drain/soil pipe.	25
C Below eaves.	25
D Below a balcony/car port roof.	25
E From vertical drain pipes and soil pipes.	25
F From internal or external corners.	25
G Above adjacent ground or balcony level.	300
H From a surface facing a terminal.	600
I Facing a terminals.	1200
J From opening (door/window) in carport into dwelling.	1200
K Vertically from a terminal on the same wall.	1500
L Horizontally from a terminal on the same wall.	300
M <sup>1</sup> Above an opening, air brick, opening window etc.	300
N <sup>1</sup> Horizontally to an opening, air brick, opening window etc.	300

<sup>1</sup>In addition, the terminal should be no nearer than 150mm to an opening in the building fabric formed for the purpose of accommodating a built-in element such as a window frame. See BS 5440 Pt. I.



## 7.0 Site Requirements

### 7.7 Flue Dimensions

The standard horizontal flue kit allows for flue lengths between 100mm and 1m from elbow to terminal (Fig. 12).

The maximum permissible equivalent flue length is:

Instant 80e	5 metres
Instant 105e	4 metres

**NOTE:** Each additional 45° of flue bend will account for an equivalent flue length of 0.5m.  
eg. 45° = 0.5m, 90° = 2 x 45° = 1m etc.

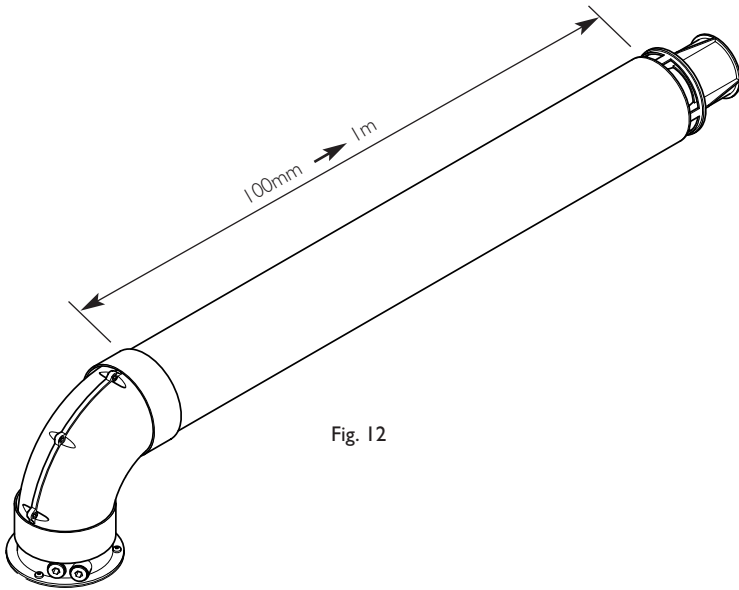

Fig. 12

### 7.8 Flue Terminal Trim

1. Once the flue is secure the trim can be fitted if required.
2. Remove the protective backing from the adhesive seal. Apply the seal to the rear of the trim flange (Fig. 13).
3. Locate the trim over the flue terminal and push it back to the wall to compress the seal (Fig. 14).

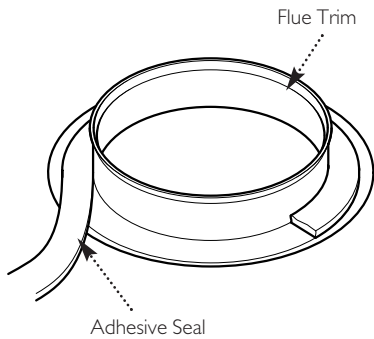

Fig. 13

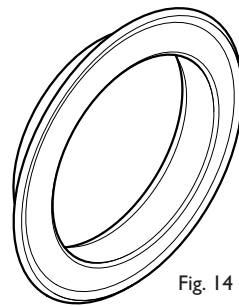

Fig. 14

### 7.9 Terminal Guard (Fig. 15)

1. When codes of practice dictate the use of terminal guards, they can be obtained from most Plumbers' and Builders' Merchants.
2. There must be a clearance of at least 50mm between any part of the terminal and the guard.
3. When ordering a terminal guard, quote the appliance name and model number.
3. The flue terminal guard should be positioned centrally over the terminal and fixed as illustrated.

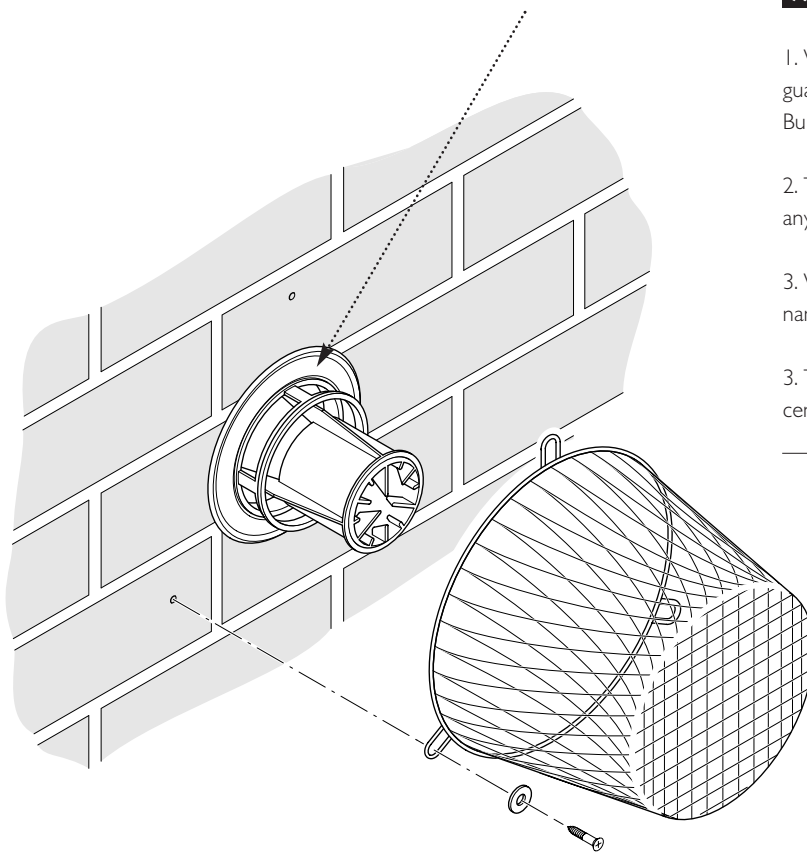

Fig. 15

## 7.0 Site Requirements

### 7.10 Flue Options

1. The Baxi Combi Instant 80e and 105e can be fitted with flue systems as illustrated.

2. The standard flue Kit No 247719 is suitable only for horizontal applications.

3. Maximum permissible equivalent flue lengths are:-

	Instant 80e	Instant 105e
Concentric	5m	4m
Vertical	4m	4m
Vertical Two-Pipe	15m	12m

4. Any additional "in line" bends in the flue system must be taken into consideration. Their equivalent lengths are:-

Concentric Pipes:

45° bend	0.5 metres
90° bend	1.0 metres

Twin Flue Pipe

45° bend	0.25 metres
90° bend	0.50 metres

The elbow supplied with the standard horizontal flue is not included in any equivalent length calculations

5. The illustrations opposite show examples of maximum equivalent lengths.

6. Full details of part numbers and descriptions of all optional flue components and kits can be found in the Baxi Combination Boilers publication.

7. Instructions for guidance and fitting are included in each kit where appropriate.

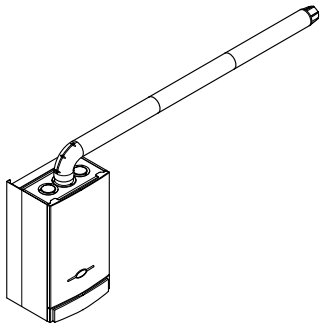

Maximum Length = 3m inc. 2 x 45° bends

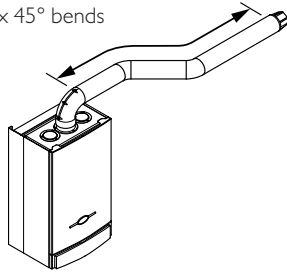
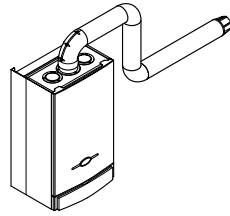

Horizontal  
Flues

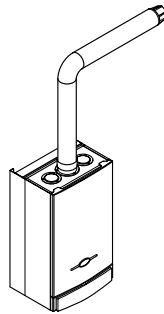
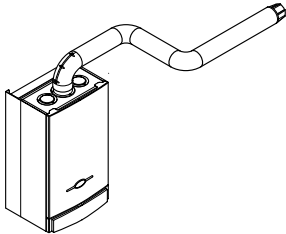

Vertical  
Flues  
(Twin Pipe)

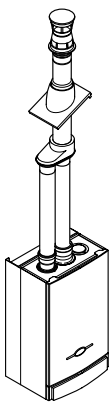

Maximum Length = 11m  
inc. 4 x 45° bends

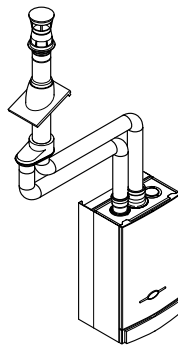
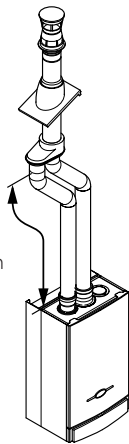

Vertical  
Flues

Maximum Length = 2m  
inc. 2 x 90° bends

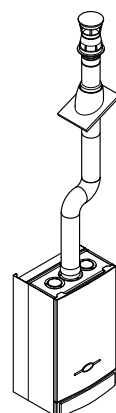
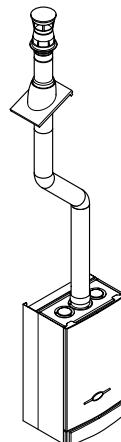
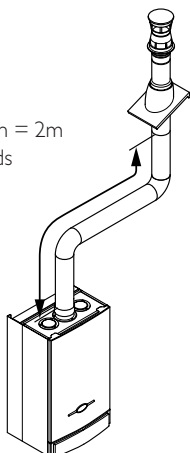
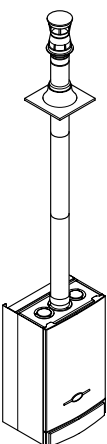

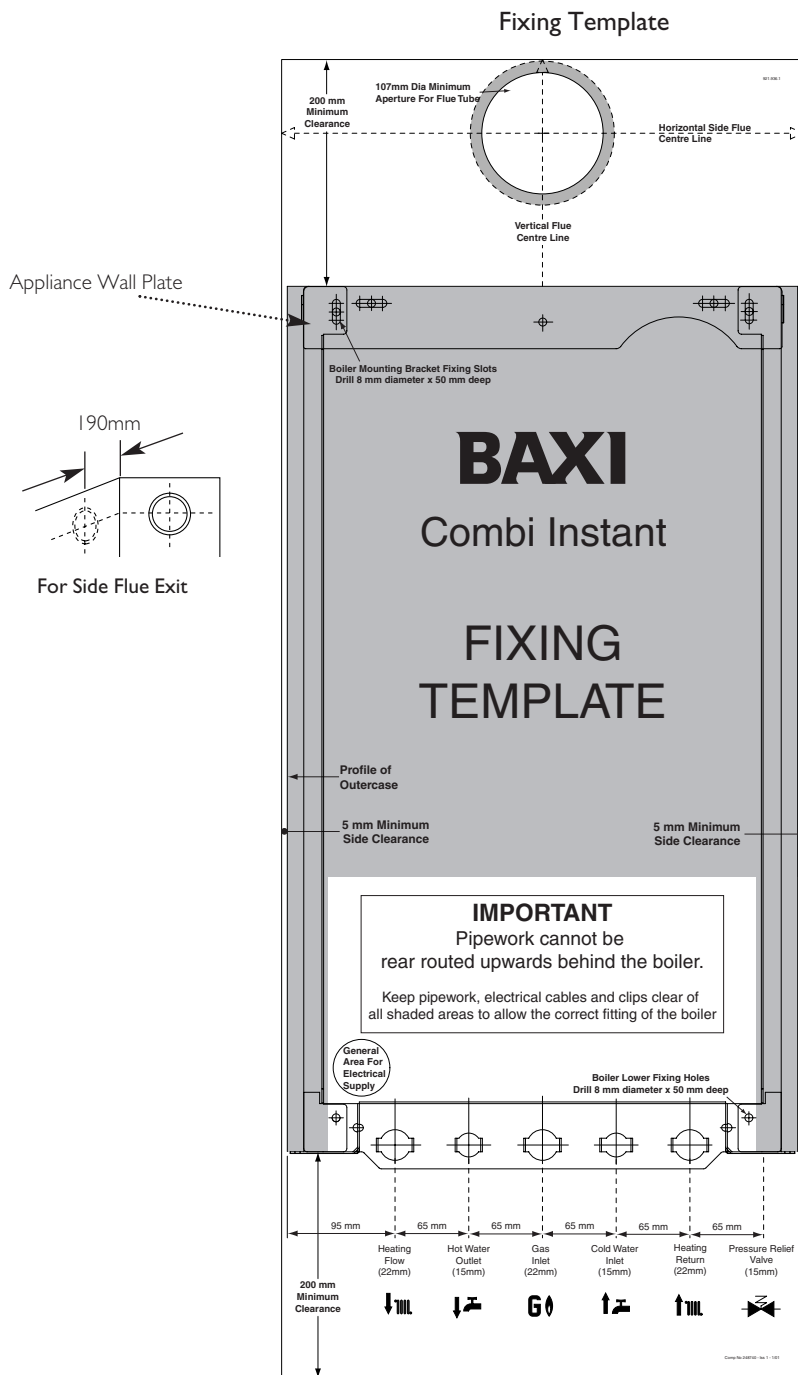

Fig. 16

## 8.0 Installation

### 8.1 Initial Preparation

The gas supply, gas type and pressure must be checked for suitability before connection (see Section 7.4).

1. After considering the site requirements (see Section 7.0) position the fixing template (Fig. 16) on the wall ensuring it is level both horizontally and vertically.
2. Mark the position of the two most suitable fixing slots for the wall plate and boiler lower fixing holes. It is preferable to use the horizontal fixing slots.
3. Mark the position of the centre of the flue hole (rear exit). For side flue exit, mark as shown.
4. **Note the shaded area on the template. Pipework cannot be routed upwards behind the boiler.**
5. If required, mark the position of the gas and water pipes. Remove the template.
6. Cut the hole for the flue (minimum diameter 107mm).
7. Drill the wall as previously marked to accept the wall plugs supplied. Secure the wall plate using the fixing screws.
8. Using a spirit level ensure that the plate is level before finally tightening the screws.
9. Connect the gas and water pipes to the valves on the wall plate using the copper tails supplied. Ensure that the sealing washers are fitted between the connections.

### 8.2 Flushing

1. Connect a tube to the central heating flow or return pipe (Fig. 17).
2. Flush thoroughly (see System Details, Section 6.2).
3. The use of the optional Baxi Filling Loop Kit (Part No. 248221) will simplify the flushing and soundness checking.

### 8.3 Preparing The Boiler

1. Remove all packaging.
2. Stand the boiler on its base by using the rear lower edge as a pivot.

**NOTE:** A small amount of water may drain from the boiler when the plastic caps are removed from the boiler connections.

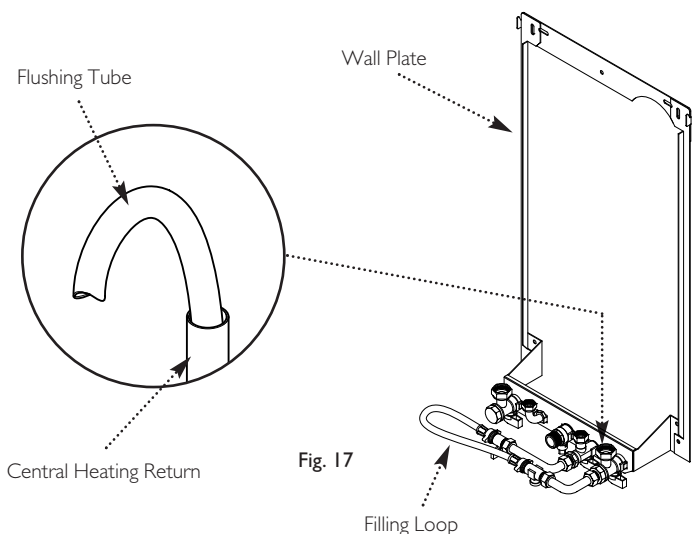

Fig. 17

## 8.0 Installation

### 8.4 Fitting The Boiler

1. Remove the sealing caps from the boiler connections.
2. Lift the boiler using the lower edges. Engage the slots at the top rear of the boiler on the wall plate (Fig. 18).
3. Insert the sealing washers between the valves and pipes on the wall plate and the boiler connections. **The rubber washers must be used on the gas connection.**
4. Tighten all the connections.

### 8.5 Fitting the Pressure Relief Discharge Pipe (Fig. 19)

1. Remove the discharge pipe from the kit.
2. Determine the routing of the discharge pipe in the vicinity of the boiler. Make up as much of the pipework as is practical, including the discharge pipe supplied.
3. The pipework must be at least 15mm diameter and run continuously downwards to a discharge point outside the building. See section 6.7 for further details.
4. Utilising one of the sealing washers, connect the discharge pipe to the adaptor and tighten the nut.
5. Complete the discharge pipework and route it to the outside discharge point.

**IMPORTANT:** Make all soldered joints before connecting to the pressure relief valve.

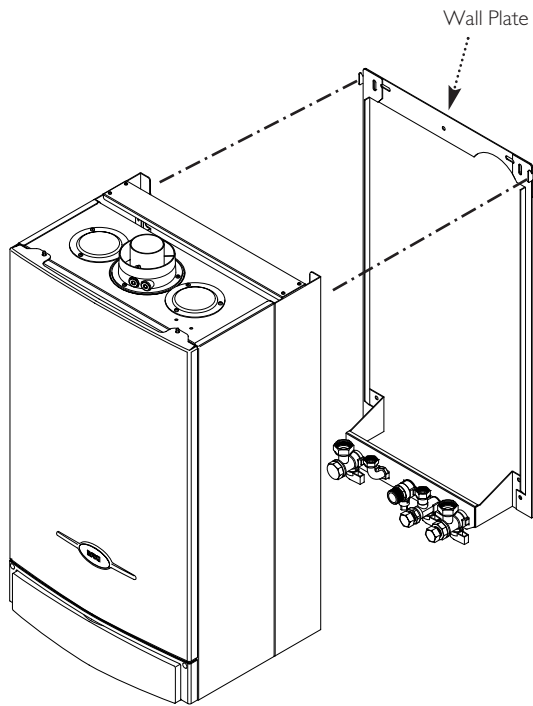

Fig. 18

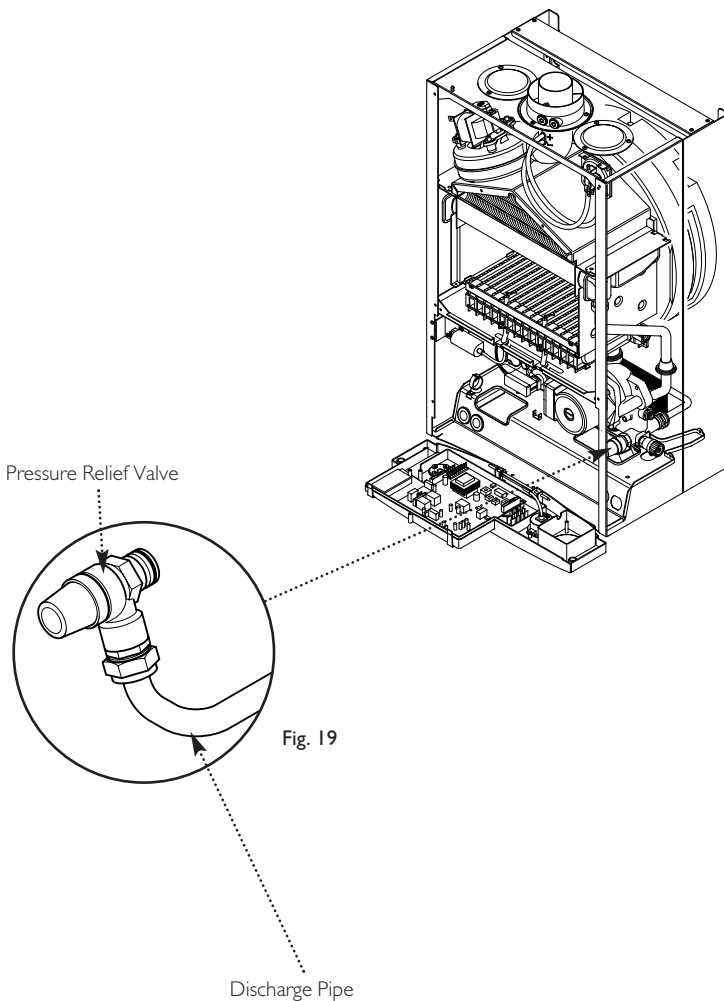

Fig. 19

## 8.0 Installation

### 8.6 Fitting The Flue

#### HORIZONTAL FLUE

1. The standard flue is suitable for lengths 100mm minimum to 1m maximum (measured from the edge of the flue elbow outlet).

Rear Flue: maximum wall thickness - 900mm

Side Flue: maximum wall thickness - 870mm

2. Locate the flue elbow on the adaptor at the top of the boiler. Set the elbow to the required orientation (rear, right or left).

3. Measure the distance from the outside wall face to the elbow (Fig. 20). This dimension will be known as 'X'.

4. Taking the air duct, mark dimension 'X' as shown (Fig. 21). Measure the length of waste material, and transfer the dimension to the flue duct (Fig. 21).

**IMPORTANT: Check all measurements before cutting.**

5. Remove the waste from both ducts. Ensure that the cut ends are square and free from burrs.

6. Remove the flue elbow from the adaptor.

7. Insert the flue duct into the air duct and pass them through the hole in the wall.

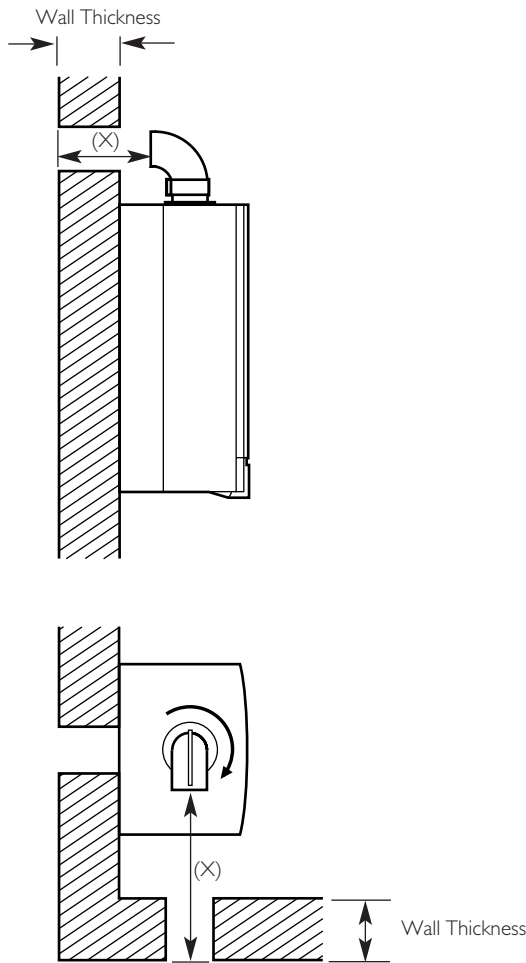

Fig. 20

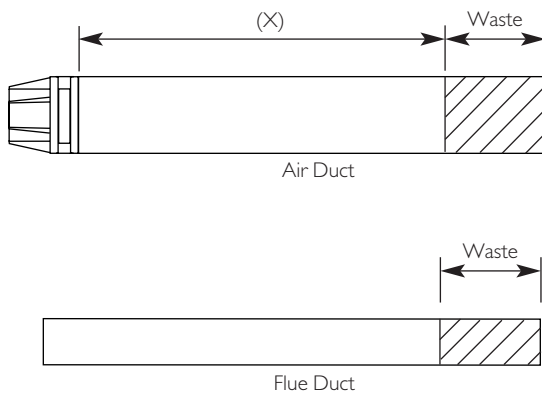

Fig. 21

## 8.0 Installation

### 8.6 Fitting the Flue (Cont)

**IMPORTANT:** If the equivalent flue length is greater than 1.5m the restrictor **MUST** be removed from the adaptor (Fig. 22).

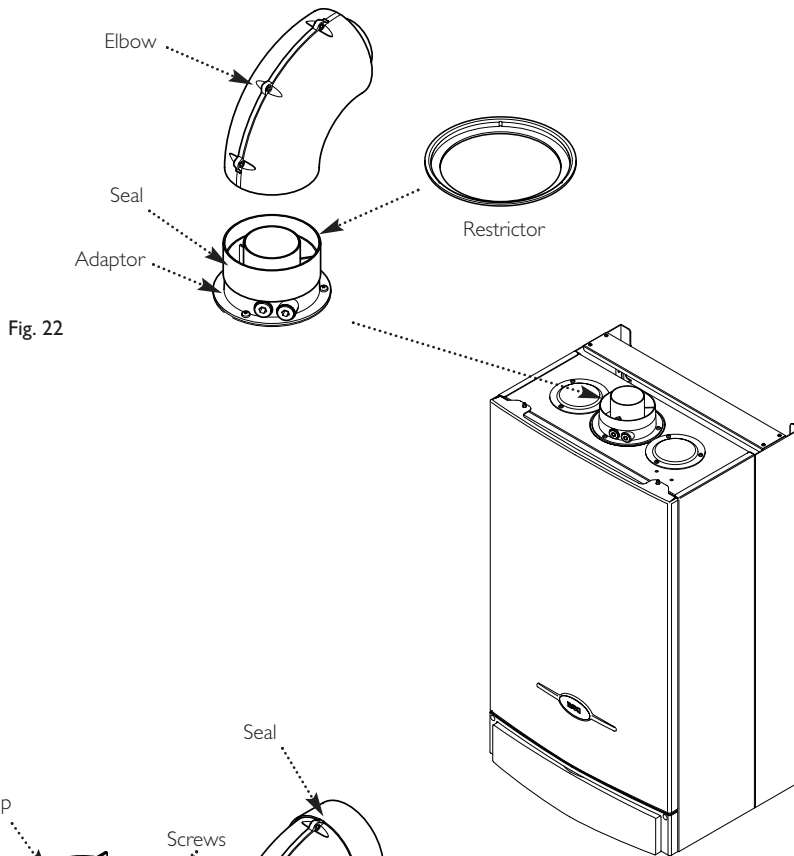

Fig. 22

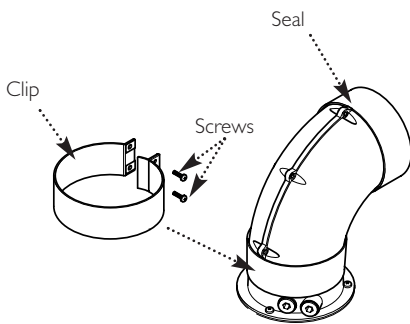

Fig. 23

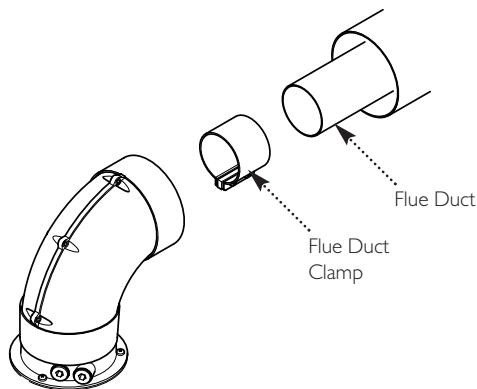

Fig. 24

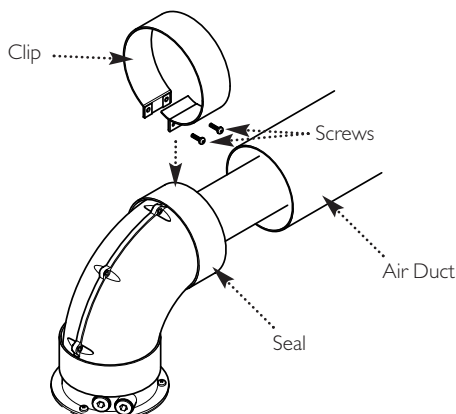

Fig. 25

8. Take one of the rubber seals and position it on the boiler flue adaptor. Engage the flue elbow on the adaptor and pull the sleeve up so that it equally covers the joint (Fig. 22).

9. Remove the screws from one of the clips provided. Prise the clip apart and fit it over the seal (Fig. 23). Set the elbow to the required angle.

10. Refit the screws to the clip and tighten them to secure the elbow. Take the second rubber seal and position it on the flue elbow.

11. Locate the flue duct clamp on the flue outlet elbow. Draw the flue duct out of the air duct, engage it in the clamp and tighten the screws (Fig. 24).

12. Draw the air duct out of the wall and align it with the elbow. Position the seal so that it equally covers the joint (Fig. 25).

13. Remove the screws from the second clip provided. Prise the clip apart and fit it over the seal. Refit the screws to the clip and tighten them (Fig. 25).

14. Where possible position the clips so that the screws are not visible.

15. Make good between the wall and air duct outside the building.

16. Fit the circular flue trim outside if required, and if necessary fit a terminal guard (see Section 7.10 & 7.11).

### 8.7 Extensions & Additional Elbows

1. The method of connecting any flue extensions or additional elbows is the same as that for connecting the standard flue and 90° elbow as described above.

2. If, for example, when a flue extension is connected to a 90° elbow the flue duct will project from the air duct at the unconnected end by the same amount as the flue duct spigot does from the elbow. Further elbows or extensions can then be added to this.

3. Similarly, a concentric flue can be connected to the boiler adaptor in the same manner as it does to the elbow to provide a vertical flue.

4. The additional 90° elbow available is identical to the elbow supplied with the standard flue. 45° elbows are of the same principle.

5. Extensions can be cut according to the requirements of the installation.



## 8.0 Installation

### 8.8 Making The Electrical Connections

To connect the mains input cable proceed as follows:-

1. Slacken the facia panel securing screws and lift the outercase panel so that its securing tabs are clear of the facia. Remove the panel.

2. Remove the screws securing the facia panel and hinge it down (Fig. 26).

3. Remove the control box cover securing screws. Disengage the barbs on the control box from the cover. Remove the cover (Fig. 27).

4. Slacken the cable clamp on the LH side of the boiler chassis (Fig. 28). Insert the cable through the clamp and route it to the terminal block.

5. Slacken the screws in the terminal block, connect the input cable, and tighten the screws.

6. If an external control is to be connected it can be done at this point. Run the input cable from the external control through the second cable clamp on the boiler chassis. Refer to the instructions supplied with the control.

7. To connect external control(s) remove the link between terminals 1 & 2. The 230V supply at terminal 1 must be connected to the external control. The switched output from the external control must be connected to terminal 2. (Fig. 29).

**NOTE:** If the room thermostat being used incorporates an anticipator it **MUST** be wired as shown in Fig. 29.

**IMPORTANT:** The external control **MUST** be suitable for 230V switching.

8. Ensure that both mains input and, where fitted, external control input cables have sufficient slack to allow the control box to drop down. Tighten the cable clamp(s) on the boiler chassis.

9. If the optional integral timer is to be used it should be fitted at this point. Refer to the instructions supplied with the timer. **NOTE: An external frost thermostat cannot be used with the integral timer.**

### 8.9 Preliminary Electrical Checks

1. Prior to commissioning the boiler preliminary electrical system checks should be carried out.

2. These should be performed using a suitable meter, and include checks for Ground Continuity, Resistance to Ground, Short Circuit and Polarity.

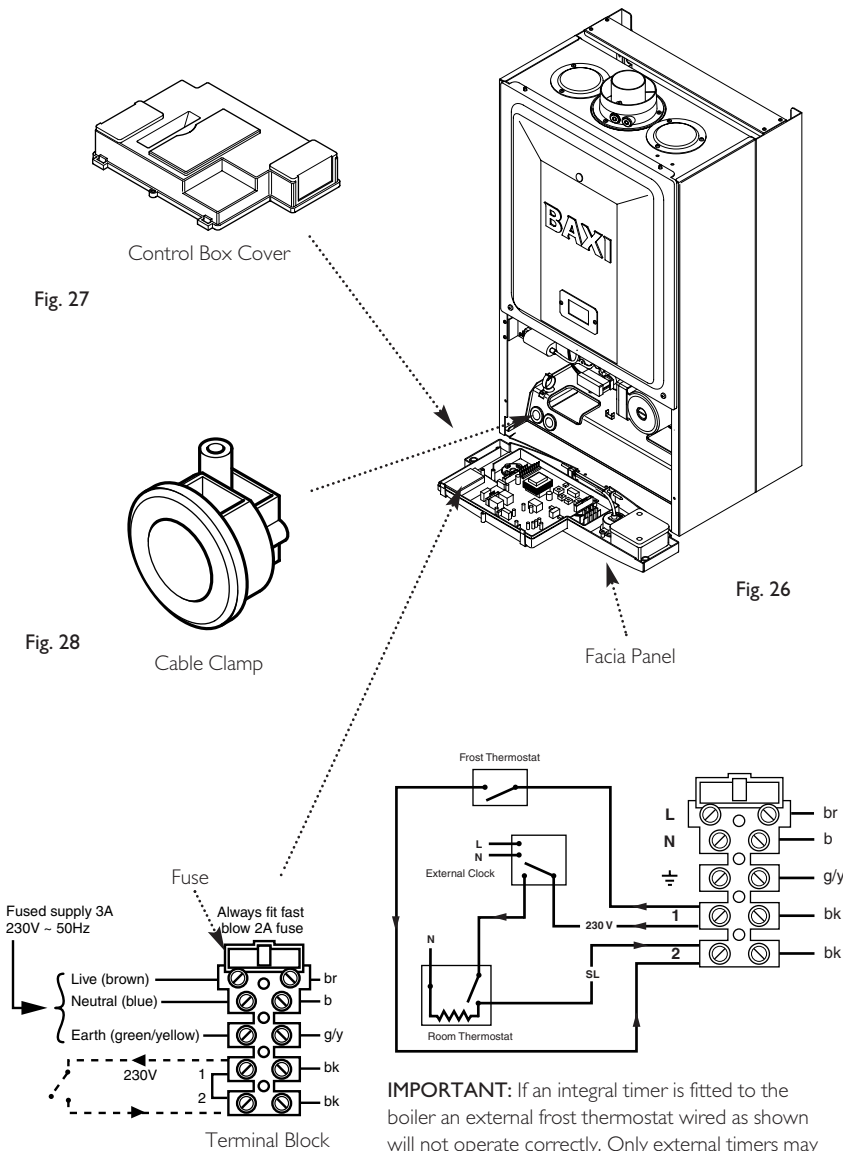
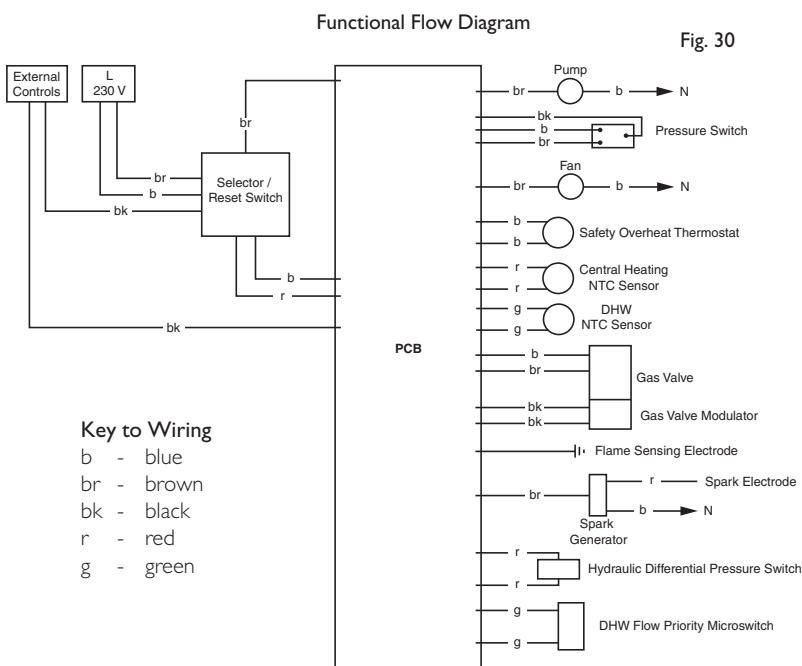

Fig. 29



## 9.0 Commissioning the Boiler

### 9.1 Commissioning the Boiler

1. Reference should be made to BS 5449 Section 5 when commissioning the boiler.
2. Open the mains water supply to the boiler.
3. Open all hot water taps to purge the DHW system.
4. Ensure that the filling loop is connected and open, then open the heating flow and return valves on the boiler.
5. Open the screw on the automatic air vent (Fig. 31).
6. The system must be flushed in accordance with BS 7593 (see Section 6.2) and the flushing agent manufacturers instructions.
7. Pressurise the system to 1.0 bar then close and disconnect the filling loop.
8. Turn the gas supply on and purge according to in GB BS 6891 and in IE I.S. 813 "Domestic Gas Installations".
9. Test for gas soundness.
10. If at any time during commissioning it is required to terminate a particular cycle, e.g. the pump overrun period, turn the selector to the OFF position and then back to either (OFF) or (PREHEAT) (Fig. 33).

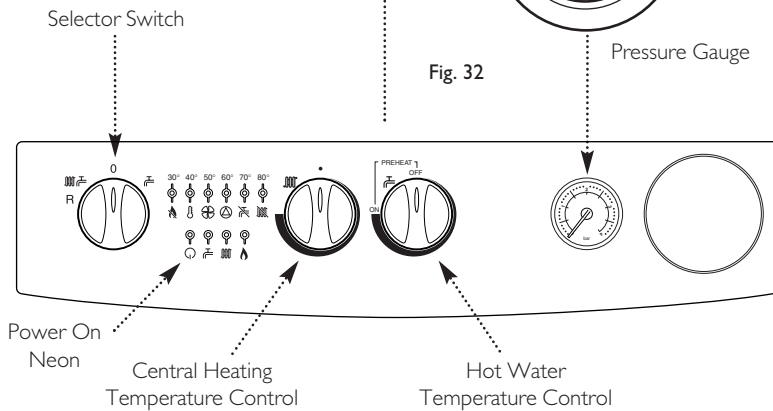
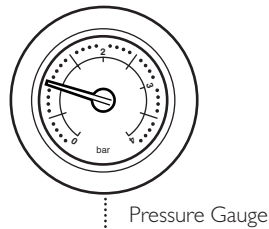
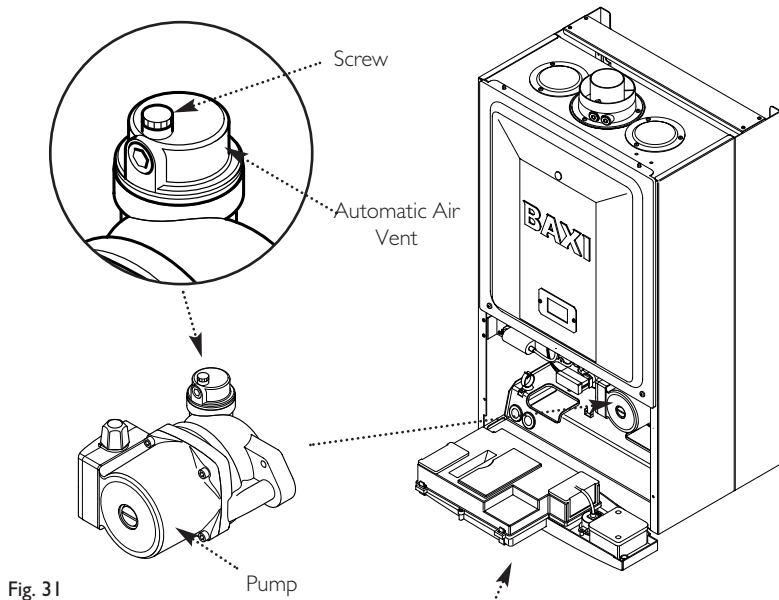

### 9.2 Checking the Burner Pressure

1. Turn on the gas and electrical supplies to the boiler and ensure that all external controls are calling for heat.
2. Set the hot water and central heating temperature controls to maximum and the selector switch to the OFF position (Fig. 37).
3. Slacken the pressure test point sealing screw (Fig. 34) on the gas valve and connect a pressure gauge.
4. Disconnect the sensing tube from the gas valve (Fig. 34).
5. Turn the selector switch fully anticlockwise against the spring pressure to position R and hold for 2 seconds to reset the boiler.
6. Turn the selector switch to the Central Heating and Domestic Hot Water position (中央). The power ON neon (ON) will illuminate (Fig. 37).
7. Turn on a hot water tap to give a flow rate of at least 10 l/min.

8. The pressure should be :-

	Instant 80e	Instant 105e
NG	12.2mbar	13.4mbar
Butane	28.3mbar	n/a
Propane	36.2mbar	35.8mbar

If not, check that the gas supply pressure is correct (Natural Gas 20mbar, Butane 30mbar and Propane 37mbar).

Also check that the **working** pressure at the gas valve is not more than 1mb lower than that at the gas meter.

9. The pressure can be adjusted if required.

10. To check and set minimum pressure first remove one of the modulator wires.

#### Adjusting the Pressure (Fig 35)

11. Remove the plastic protection cap from the pressure adjustment nuts on the valve.
12. The smaller nut (5mm) adjusts minimum pressure and the larger nut (8mm) maximum pressure.
13. Using a suitable spanner adjust the relevant nut until the correct pressure is achieved.
14. Once the pressure has been set turn the boiler off and disconnect the pressure gauge.
15. Tighten the pressure test screw and refit the modulator to the valve. Reassemble in reverse order.

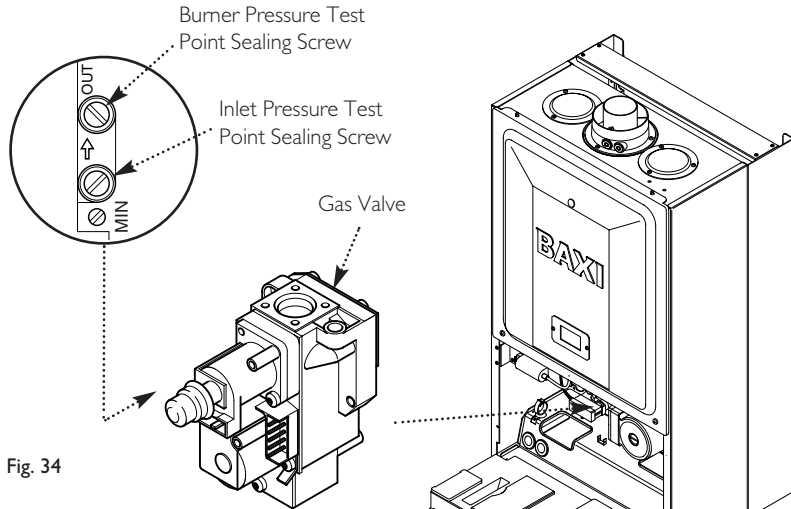

Fig. 34

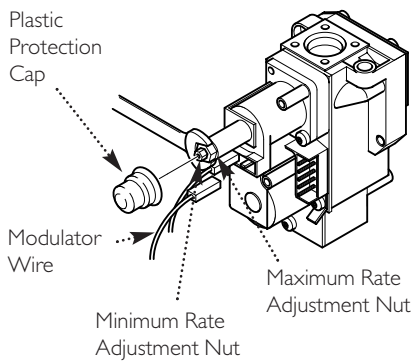

Fig. 35

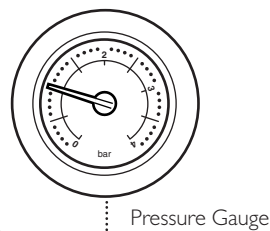

Fig. 36

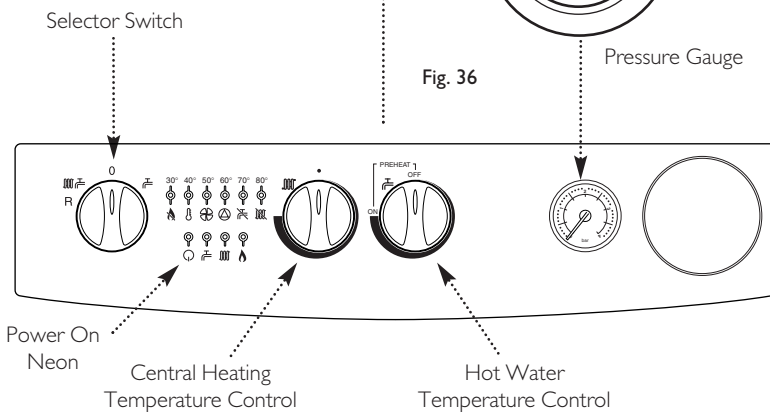
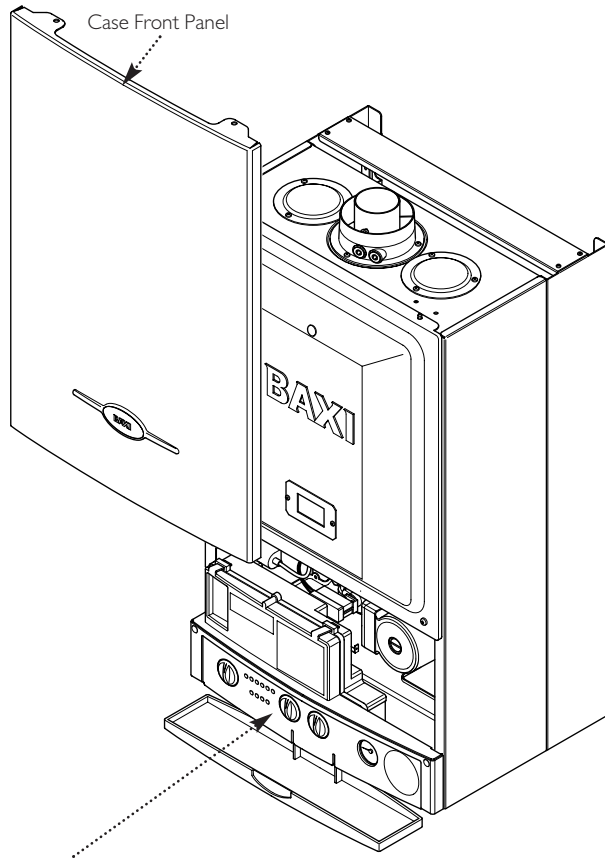

Fig. 37

## 10.0 Completion

### 10.1 Completion

1. Hinge the facia panel upwards and refit the case front panel. Secure them with the screws previously removed (Fig. 38).
2. Instruct the user in the operation of the boiler and system, explaining the operational sequence.
3. Carefully read and complete all sections of the Benchmark Commissioning Checklist at the rear of this publication that are relevant to the appliance and installation. These details will be required in the event of any warranty work. The publication must be handed to the user for safe keeping and each subsequent regular service visit recorded.
4. For IE, it is necessary to complete a "Declaration of Conformity" to indicate compliance with I.S. 813. An example of this is given in I.S. 813 "Domestic Gas Installations". This is in addition to the Benchmark Commissioning Checklist.
5. Hand over the Users Operating, Installation and Servicing Instructions, giving advice on the necessity of regular servicing.



Facia Panel

Fig. 38

## 11.0 Servicing the Boiler

### 11.1 Annual Servicing

1. For reasons of safety and economy, it is recommended that the boiler is serviced annually. Servicing must be performed by a competent person.
2. After servicing, complete the relevant Service Interval Record section of the Benchmark Commissioning Checklist at the rear of this publication.
3. Ensure that the boiler is cool.
4. **Ensure that both the gas and electrical supplies to the boiler are isolated.**
5. Slacken the screws securing the fascia panel. Lift the outercase panel so that its securing tabs are clear of the fascia. Remove the panel (Fig. 39).
6. Remove the screws (2 on Instant 80e, 4 on Instant 105e) securing the inner door panel. Lift the panel slightly to disengage it from the studs on top of the case (Fig. 40).
7. Note the positions of the two sensing tubes on the outlet elbow and three wires on the fan motor and remove them (Fig. 41).
8. Slacken the screws on the outlet sealing collar. Ease the collar upwards as far as possible (Fig. 41).
9. Remove the four screws securing the combustion box door and remove the door (Fig. 40).

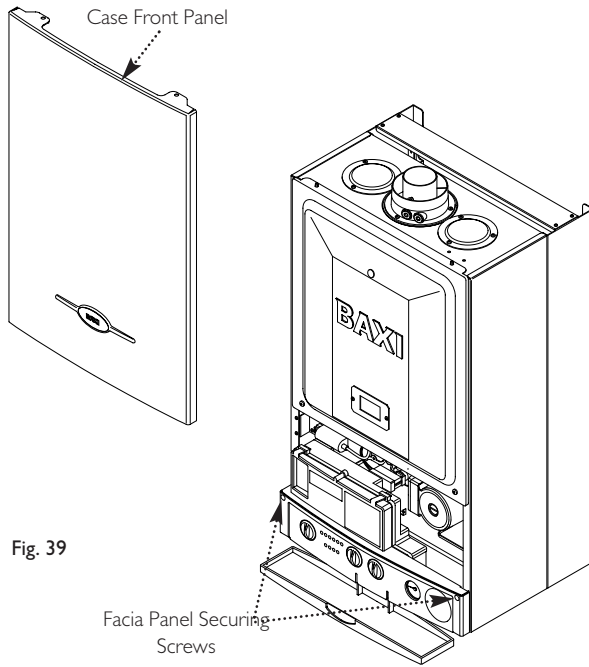

Fig. 39

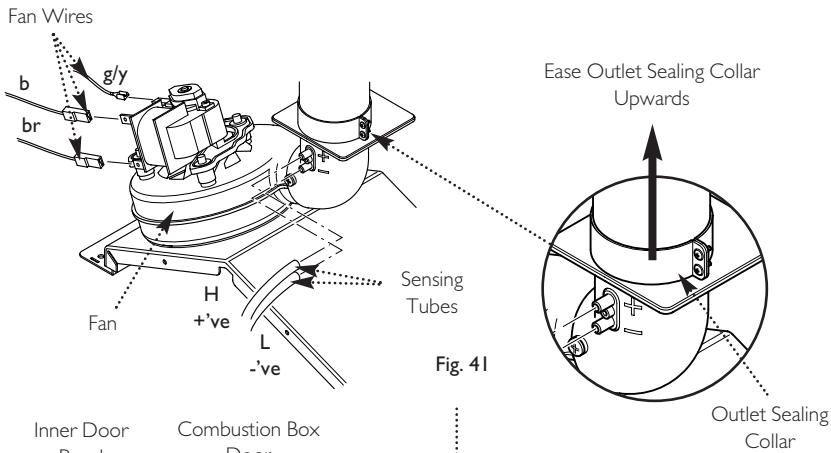

Fig. 41

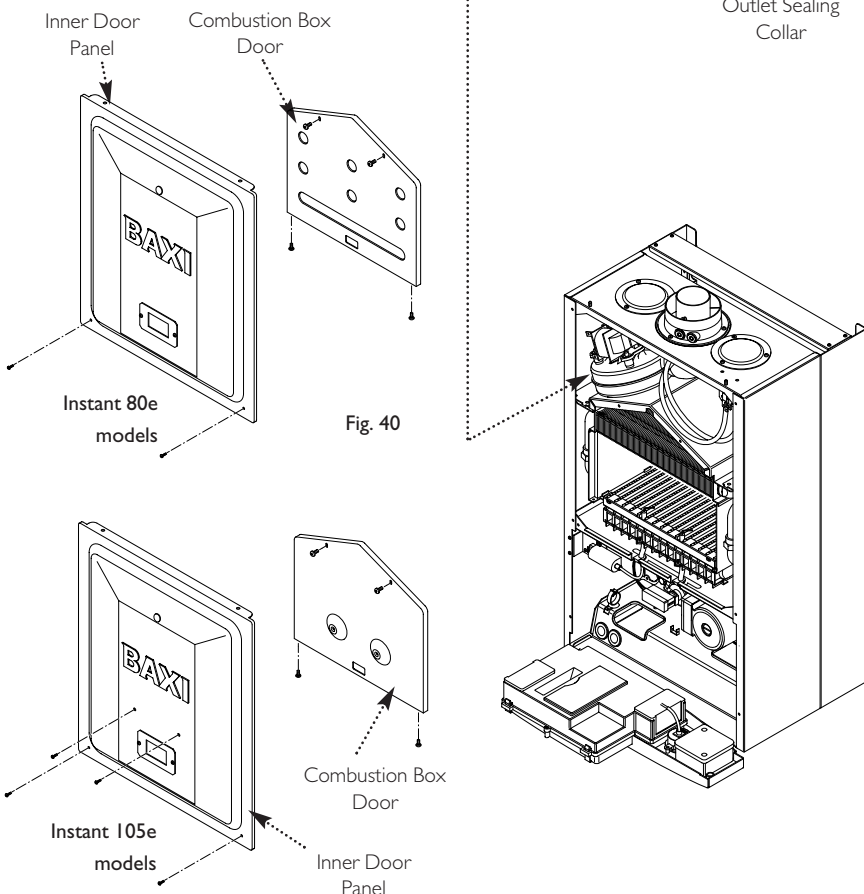

Fig. 40

## 11.0 Servicing the Boiler

### 11.1 Annual Servicing (Cont)

10. Remove the spring clips retaining the air box side baffle plates. Disengage the tabs on the baffles from the slots in the fan hood (Fig. 42).

11. Undo the screws securing the fan and hood to the appliance back panel. Draw the assembly forwards (Fig. 42a).

12. Undo the screws securing the burner to the injector manifold (Instant 105e model only). Draw the burner out of the combustion box, pulling the electrode grommets from the slots in the combustion box lower panel (Fig. 43).

13. Disconnect the electrode leads and grommets from the electrodes. Completely remove the burner (Fig. 43).

14. Brush any deposits from the injectors. Do not use a pin or wire to clean them.

15. Brush the burner blades and venturis and clean the combustion box.

16. Ensure that the heat exchanger fins are clear of any obstruction.

#### DHW Filters (Fig. 44)

17. If the flow of domestic hot water is diminished, it may be necessary to clean the filters.

18. Initially check the cold water inlet tap filter.

19. Turn the tap off. Undo the blanking cap and remove the threaded bush (Fig. 43a).

20. Extract the filter and rinse thoroughly in clean water. Reassemble and check the flow. If required clean the manifold filter as described below.

21. Undo the filter cartridge from the inlet/return manifold.

22. Dismantle the cartridge and carefully remove the flow regulator and filter gauze. Rinse them thoroughly in clean water and reassemble in reverse order.

23. Check that the pressure vessel charge is 0.5bar and reassemble in reverse order of dismantling.

24. Turn the selector switch fully anticlockwise against the spring pressure to position R and hold for 2 seconds to reset the boiler before recommissioning.

25. Complete the relevant Service Interval Record section of the Benchmark Commissioning Checklist at the rear of this publication and then hand it back to the user.

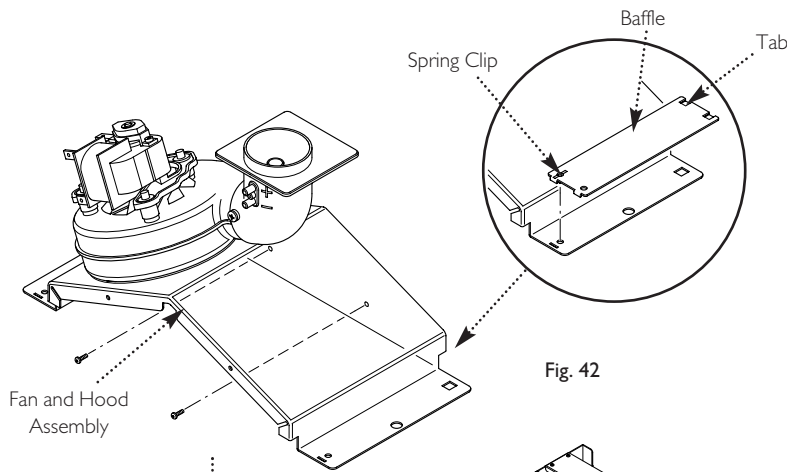

Fig. 42

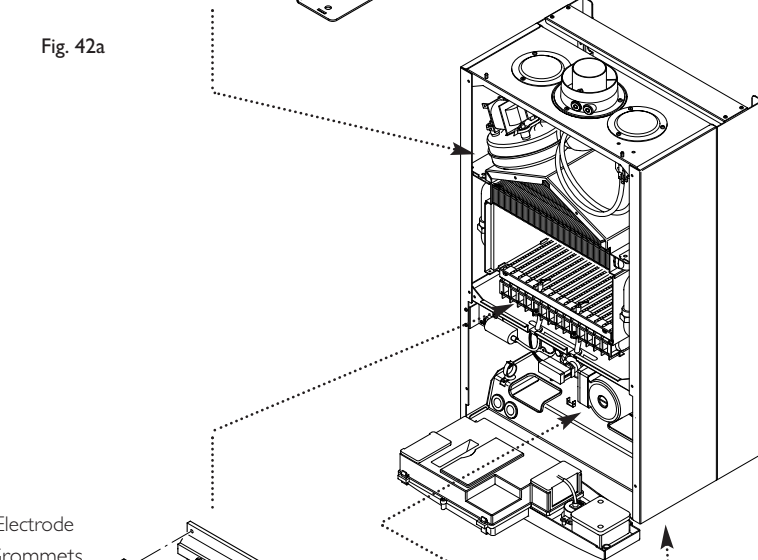

Fig. 42a

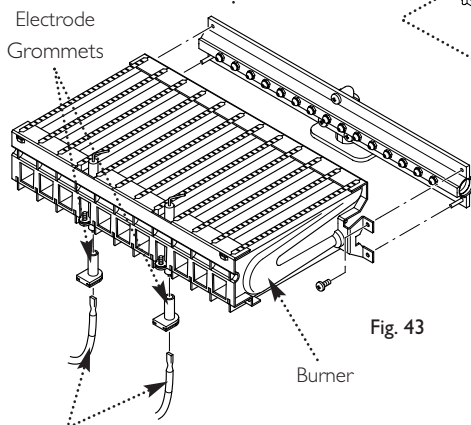

Fig. 43

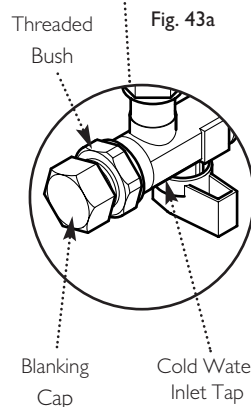

Fig. 43a

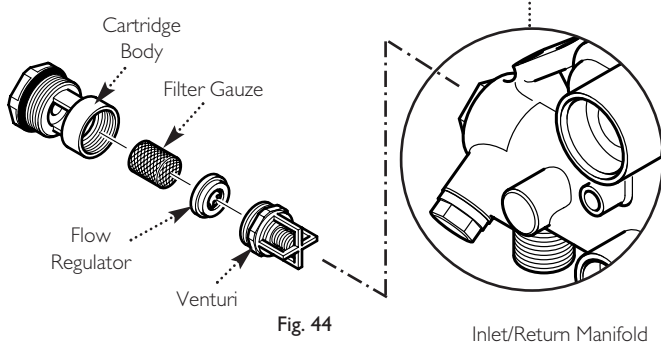

Fig. 44

Inlet/Return Manifold

## 12.0 Changing Components

**IMPORTANT:** When changing components ensure that both the gas and electrical supplies to the boiler are isolated before any work is started. When the new component has been fitted turn the selector switch fully anticlockwise against the spring pressure to position R and hold for 2 seconds to reset the boiler before recommissioning.

See Section 11.1 "Annual Servicing" for removal of case panel, door etc.

### 12.1 Pressure Switch (Fig. 45)

1. Note the positions of the two sensing tubes and three wires and remove them.

2. Remove the two screws holding the pressure switch to the combustion box top panel.

3. Fit the new pressure switch and reassemble all components in reverse order of dismantling.

### 12.2 Fan (Figs. 46 & 47)

1. Note the positions of the two sensing tubes on the outlet elbow and three wires on the fan motor and remove them.

2. Slacken the screws on the outlet sealing collar. Ease the collar upwards as far as possible.

3. Remove the four screws securing the combustion box door and remove the door.

4. Remove the spring clips retaining the air box side baffle plates. Disengage the tabs on the baffles from the slots in the fan hood.

5. Undo the screws securing the fan hood to the appliance back panel, and draw the fan and hood assembly forwards.

6. Remove the screws and spring washers securing the fan to the hood.

7. Fit the new fan to the hood using the screws and spring washers previously removed.

8. Reassemble in reverse order of dismantling.

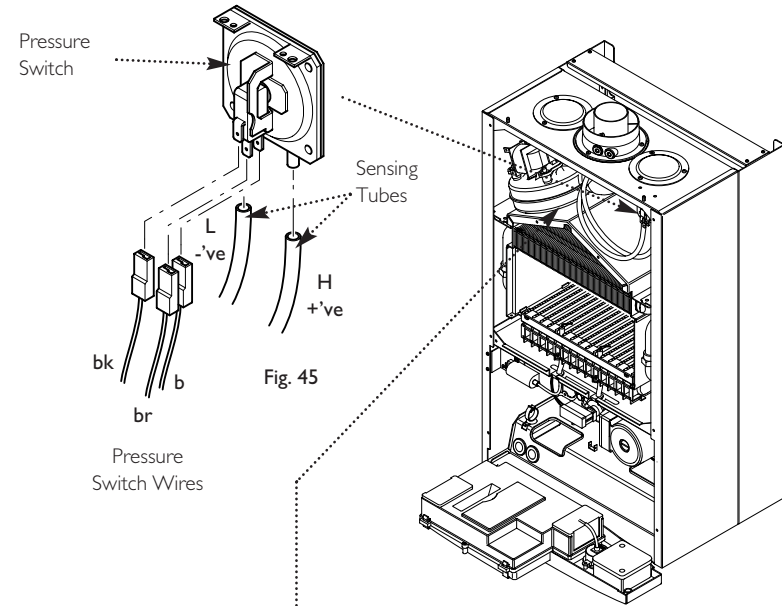

Fig. 45

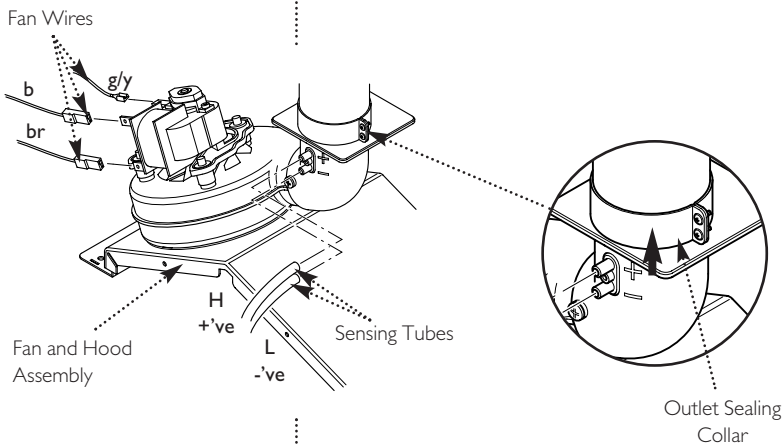

Fig. 46

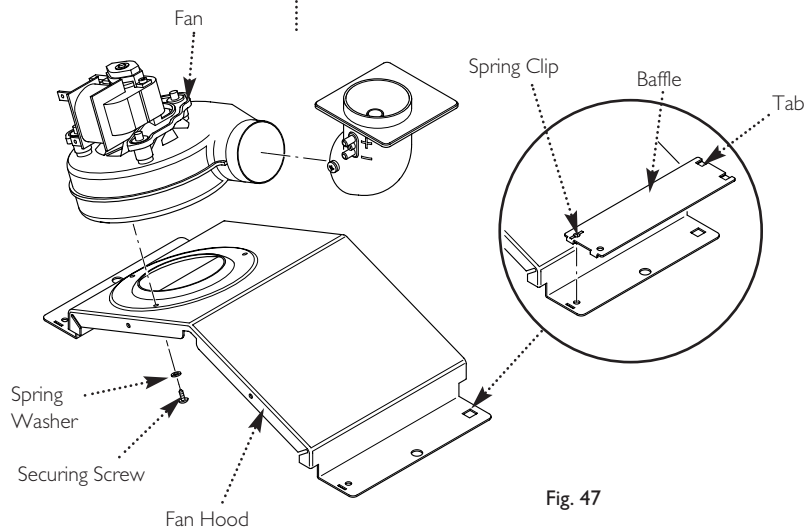

Fig. 47

## 12.0 Changing Components

### 12.3 Heat Exchanger (Fig. 48)

1. Note the positions of the two sensing tubes on the outlet elbow and three wires on the fan motor and remove them.

2. Slacken the screws on the outlet sealing collar. Ease the collar upwards as far as possible.

3. Remove the four screws securing the combustion box door and remove the door.

4. Remove the spring clips retaining the air box side baffle plates. Disengage the tabs on the baffles from the slots in the fan hood.

5. Undo the screws securing the fan hood to the appliance back panel, and draw the fan and hood assembly forwards.

6. Drain the primary circuit. Prise the two pipe connecting clips off the joints in the flow and return pipes.

7. Lift the heat exchanger to disconnect the flow and return pipe joints. Withdraw it from the appliance, taking care not to damage the rear insulation piece.

8. Fit the new heat exchanger.

9. Reassemble in reverse order of dismantling, and repressurise the system.

### 12.4 Burner (Fig. 49)

1. Remove the four screws securing the combustion box door and remove the door.

2. Undo the screws securing the burner to the injector manifold (Instant 105e model only). Draw the burner out of the combustion box, pulling the electrode grommets from the slots in the combustion box lower panel.

3. Disconnect the electrode leads and grommets from the electrodes. Completely remove the burner.

4. Undo the screws securing the electrodes to the burner. Examine the condition of the electrodes, replacing if necessary. Fit the electrodes to the new burner.

5. Engage the burner location brackets over the studs on the injector manifold and reassemble in reverse order.

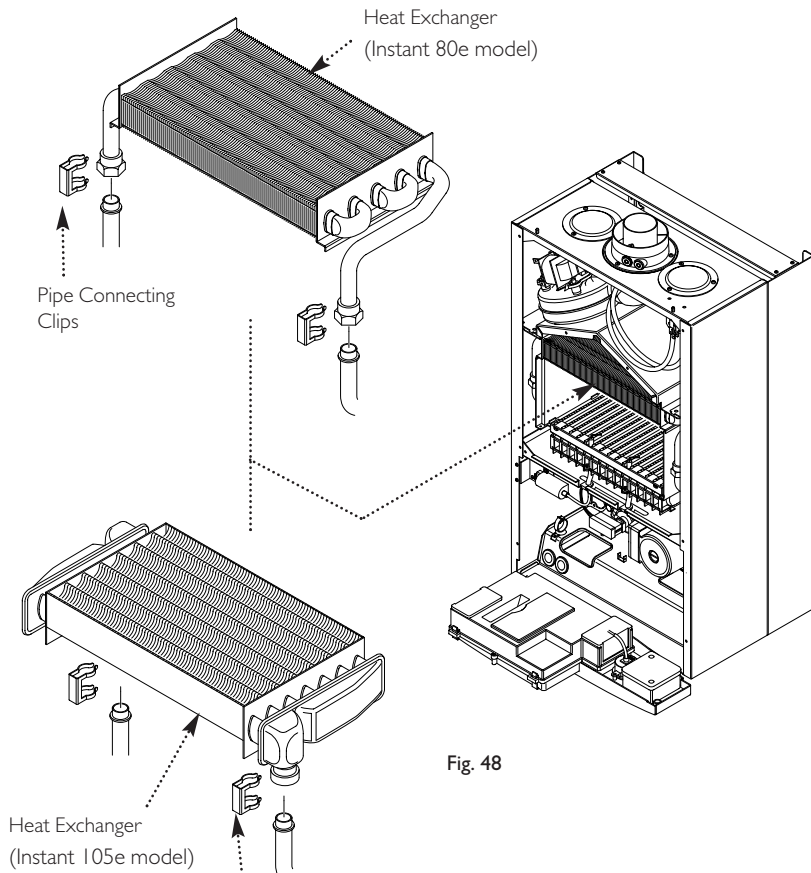

Fig. 48

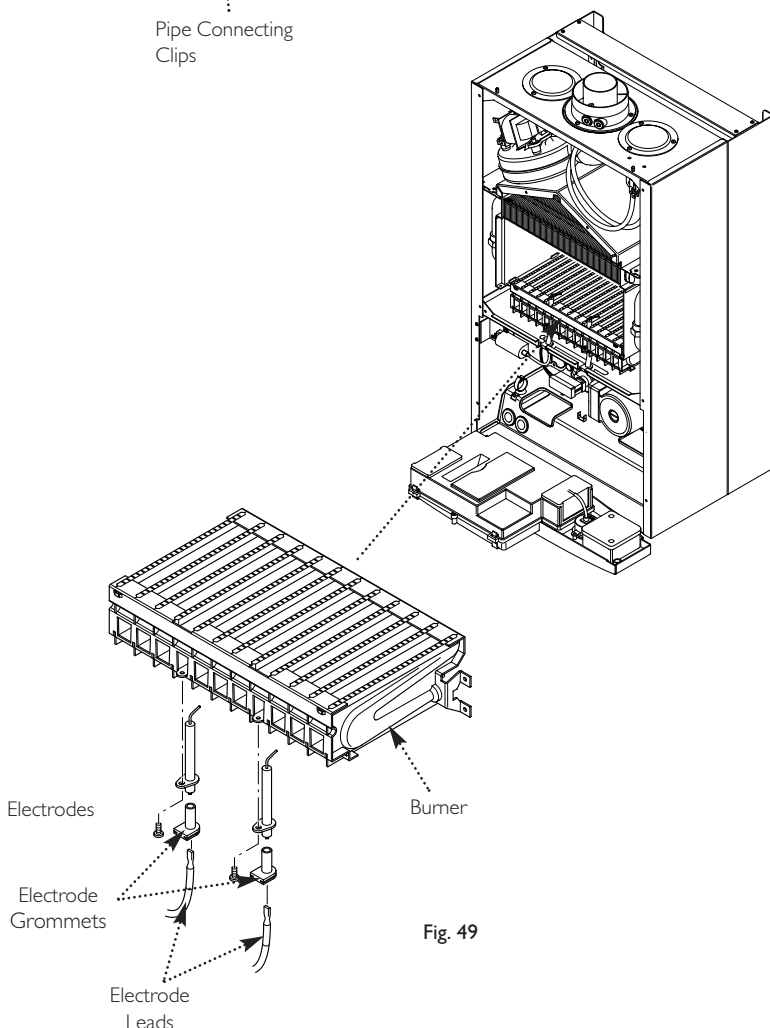

Fig. 49



## 12.0 Changing Components

### 12.5 Injectors (Fig. 50)

1. Remove the burner as described in Section 12.4.
2. Undo the screws securing the injector manifold to the inlet elbow and remove the manifold.
3. Unscrew and replace injectors as required and examine the sealing gasket, replacing as necessary. Reassemble in reverse order.

### 12.6 Electrodes (Fig. 50)

1. Remove the four screws securing the combustion box door and remove the door.
2. Undo the screws securing the burner to the injector manifold (105e model only). Draw the burner out of the combustion box, pulling the electrode grommets from the slots in the combustion box lower panel.
3. Disconnect the lead and grommet from the electrode being replaced. Undo the securing screw and withdraw the electrode to the burner.
4. Reassemble in reverse order.

### 12.7 Insulation (Fig. 51)

1. Remove the four screws securing the combustion box door and remove the door.
2. Slide the side insulation pieces carefully out of their carriers.
3. To replace the rear insulation piece it is necessary to remove the heat exchanger as described in Section 12.3 and slide out the side pieces.
4. The combustion box door insulation piece can be replaced by carefully bending up the two retaining tabs.
5. Replace all insulation pieces and reassemble in reverse order.

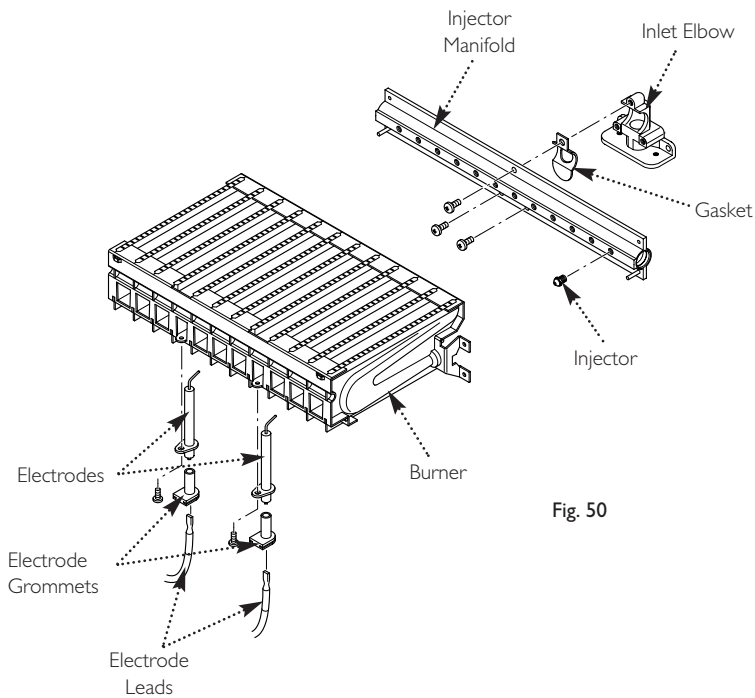

Fig. 50

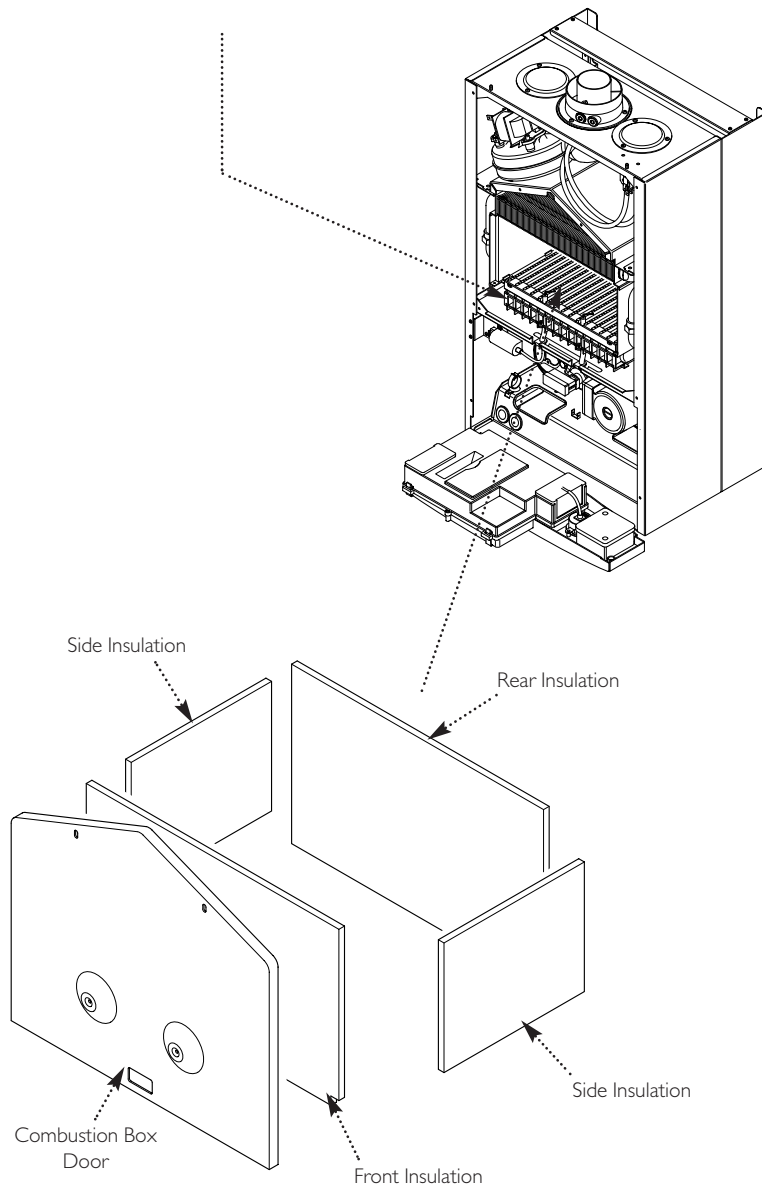

Fig. 51

## 12.0 Changing Components

### 12.8 Gas Valve (Fig. 52)

1. Undo the nut on the gas feed pipe under the boiler.
2. Remove the securing screws and hinge the facia panel down.
3. Disconnect the earth wire and pressure sensing pipe from the valve. Undo the screw securing the electrical plug to the valve and disconnect the plug. Disconnect the wires from the valve modulator.
4. Remove the screws securing the inlet pipe flange to the boiler bottom panel and those securing the outlet manifold to the burner manifold.
5. Remove the valve from the boiler.
6. Note the orientation of the inlet pipe and outlet manifold. Undo the securing screws and remove the pipe and manifold.
7. Examine the 'O' ring seals for damage, replacing as necessary.
8. Fit the inlet pipe and outlet manifold to the new valve, ensuring that the 'O' ring seals are in place.
9. Reassemble in reverse order and check the burner pressure (Section 9.2).

### 12.9 Central Heating Temperature Sensor (Fig. 53)

1. Ease the retaining tab on the sensor away and disconnect the electrical plug.
2. Unscrew the sensor from its pocket and reassemble in reverse order. The electrical plug will only fit one way.

### 12.10 Safety Thermostat (Fig. 53)

1. Pull the electrical connections off the thermostat.
2. Remove the screws securing the thermostat to the mounting plate on the flow pipe.
3. Reassemble in reverse order. The thermostat is not polarised - either wire can fit either terminal on the thermostat.

### 12.11 DHW Temperature Sensor (Fig. 53a)

1. Turn off the mains water supply and draw off the residual domestic hot water.
2. Ease the retaining tab on the sensor away and disconnect the electrical plug.
3. Unscrew the sensor from the plate heat exchanger manifold. Examine the sealing washer, replacing if necessary.
4. Reassemble in reverse order. The electrical plug will only fit one way.

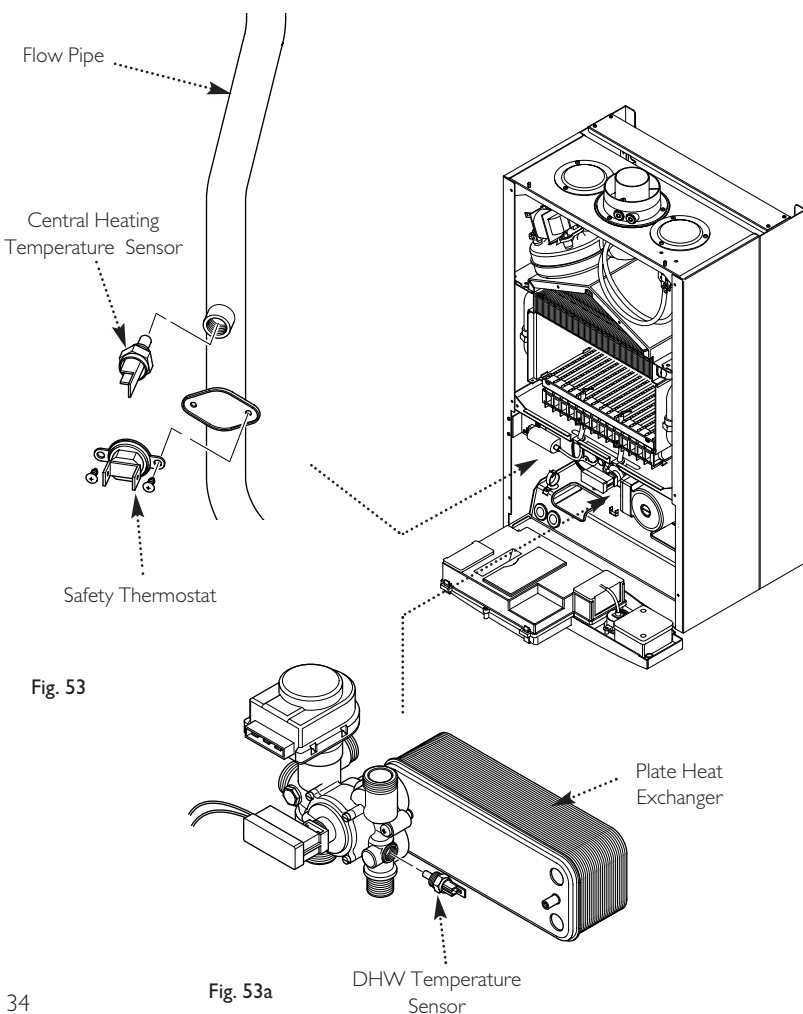
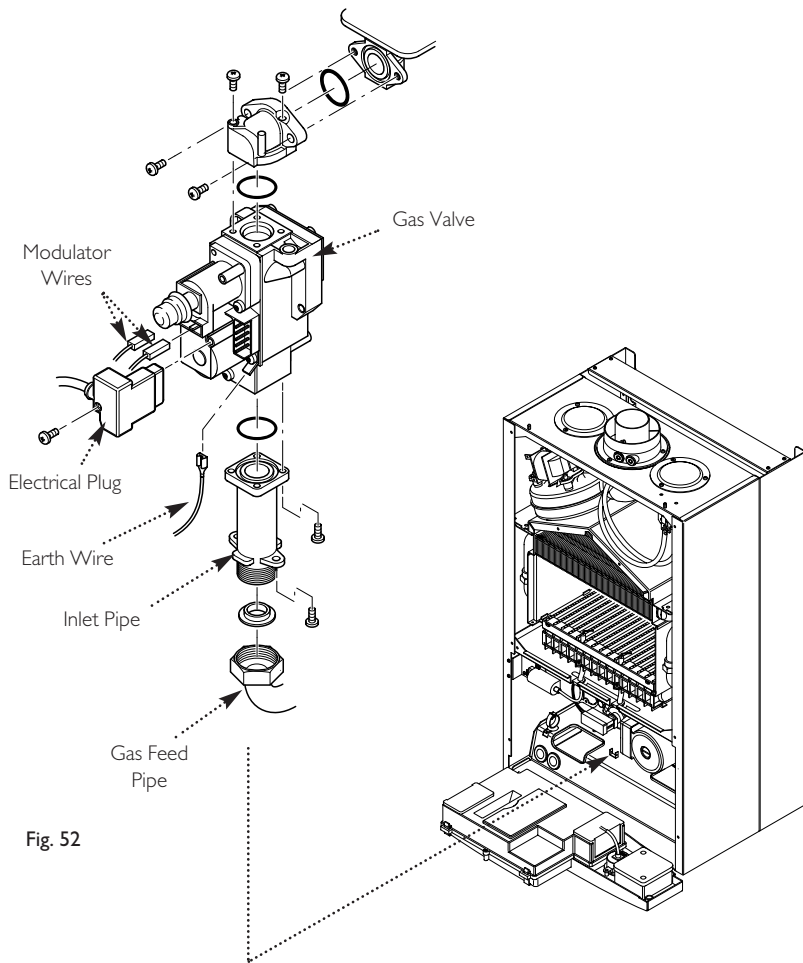

## 12.0 Changing Components

### 12.12 Pump - Head Only (Fig. 54)

1. Drain the primary circuit and remove the socket head screws securing the pump head to the body and draw the head away.

2. Undo the screw on the pump wiring cover and remove the cover. Using a suitable flat bladed screw driver press the cable securing levers downwards to release each wire after noting their position.

3. A standard Grundfos replacement head can now be fitted. A Grundfos 15-50 head is suitable for the Instant 80e. The Instant 105e requires a 15-60 head. Connect the wiring to the new head. **The pump speed must be set to 3** (Fig. 55).

4. Reassemble in reverse order.

### 12.13 Pump - Complete (Fig. 56)

1. Drain the primary circuit and unscrew the automatic air vent from the pump body. Undo the two screws securing the body to the pipe and manifold and draw the pump forwards.

2. Undo the screw on the pump wiring cover and remove the cover. Using a suitable flat bladed screw driver press the cable securing levers downwards to release each wire after noting their position.

3. Connect the wiring to the new pump. Examine the 'O' ring seals on the return pipe and manifold, replacing if necessary.

4. Fit the air vent to the pump body and reassemble in reverse order.

### 12.14 Automatic Air Vent (Fig. 56)

1. Drain the primary circuit and unscrew the automatic air vent from the pump body.

2. Examine the 'O' ring seal, replacing if necessary, and fit it to the new automatic air vent.

3. Reassemble in reverse order.

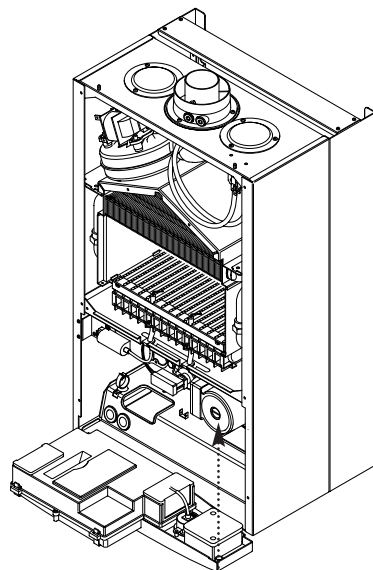
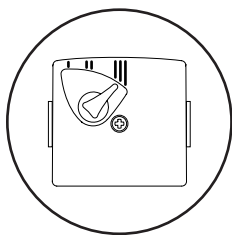
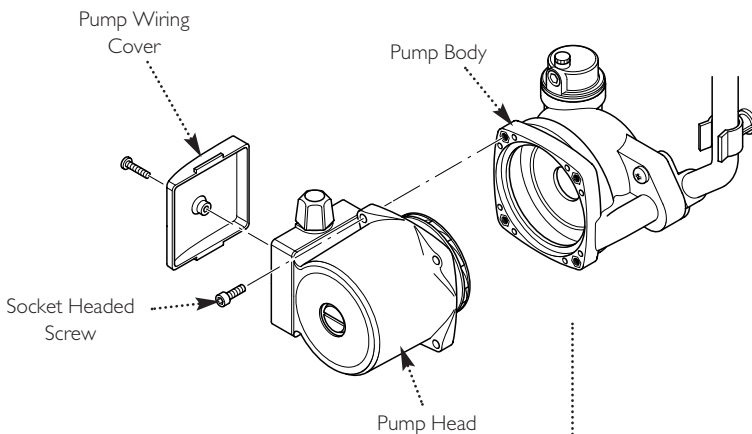

Fig. 54



Pump Setting

Fig. 55

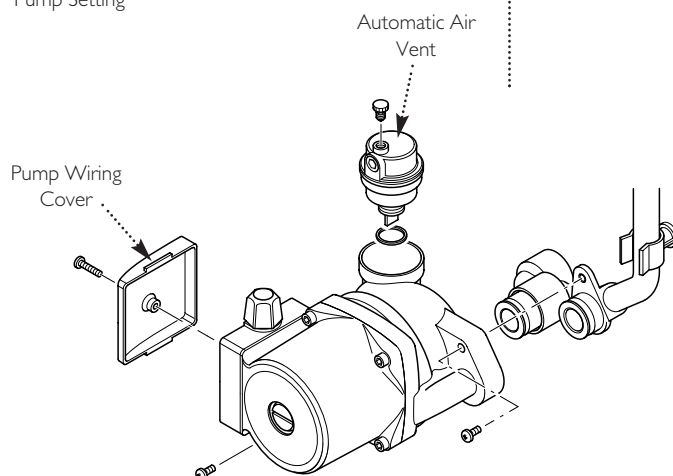

Fig. 56

## 12.0 Changing Components

### 12.15 Pressure Gauge (Figs. 57 & 58)

1. Drain the primary circuit and undo the nut on the pressure gauge capillary.
2. Remove the timer cover and ease the timer wiring aside. Undo the screws securing the gauge retaining bracket.
3. Remove the bracket and gauge assembly. Depress the barbs on the side of the gauge and remove the retaining bracket.
4. Reassemble in reverse order.

### 12.16 Expansion Vessel & Pre-Heat Store (Fig. 59)

1. To replace the expansion vessel and pre-heat store it is necessary to remove the boiler from the wall.
2. Drain the system and undo all gas and water connections. Remove the flue elbow.
3. Lift the boiler off the wall plate and lay it on either side on a clean flat surface.
4. Undo the unions on pipe 'A' and remove the pipe (Fig. 59).
5. Undo the union on pipe 'B' connected to the vessel (Fig. 59) and remove the locknut securing the vessel spigot to the boiler chassis.
6. Undo the screws and remove the appliance upper cross member. Slide the expansion vessel and insulation out of the retaining clips.
7. Reassemble in reverse order using new sealing washers. Fully recommission the appliance and system.

### 12.17 Spark Generator (Fig. 60)

1. Pull the electrode lead off the spark generator. Remove the screws and spring washers securing the generator to its mounting bracket.
2. Pull the rubber shroud off the generator input plug and disconnect the plug.
3. Reassemble in reverse order.

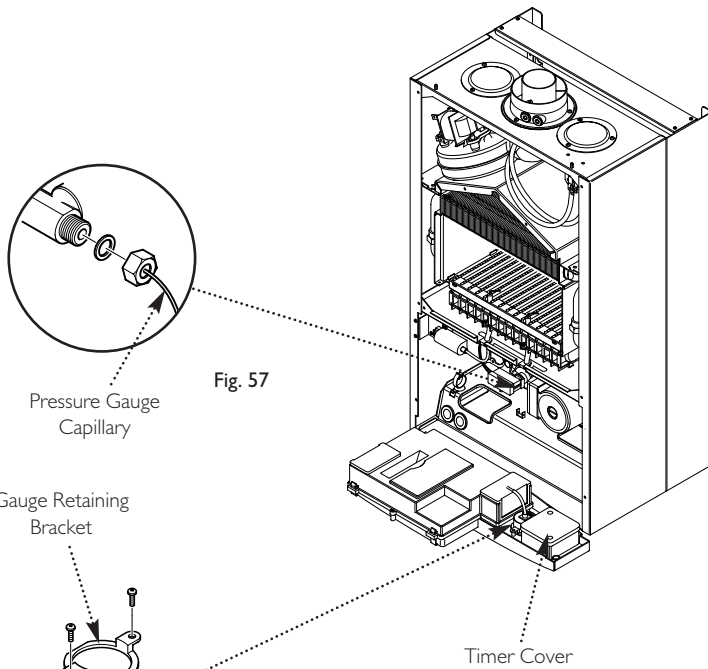

Fig. 57

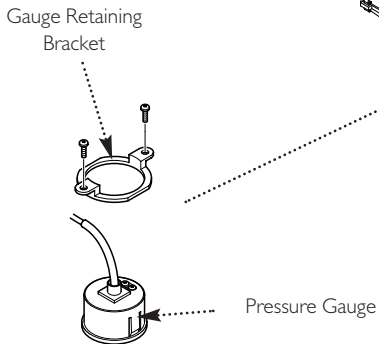

Fig. 58

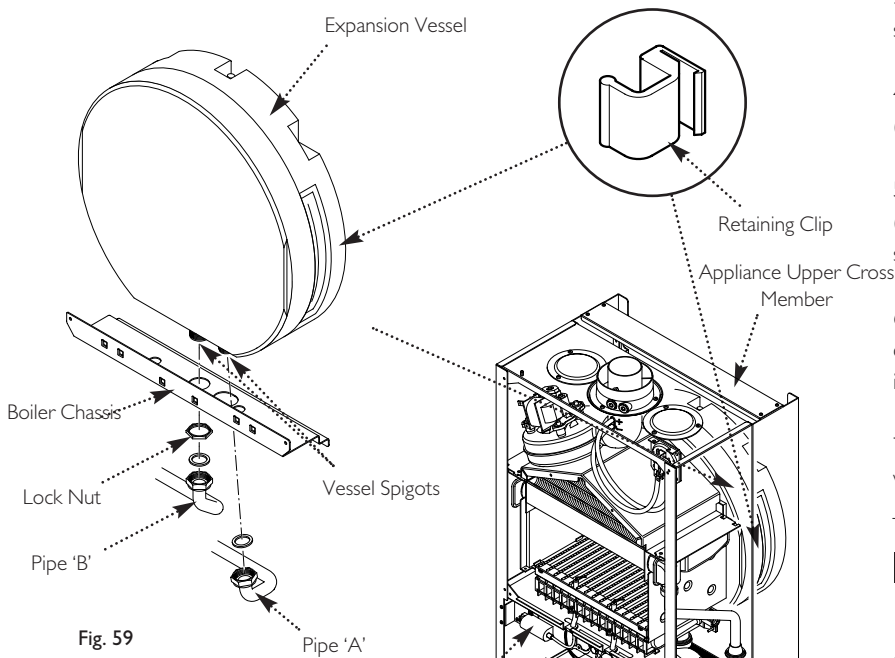

Fig. 59

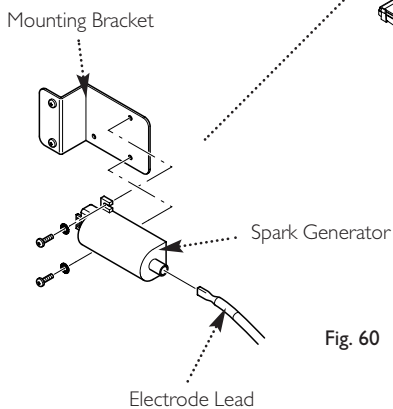

Fig. 60

## 12.0 Changing Components

### 12.18 Pressure Relief Valve (Fig. 61)

1. Drain the primary circuit.
2. Disconnect the discharge pipe from the valve. Using a suitable hexagon key undo the grub screw sufficiently to release the valve.
3. Note the orientation of the valve, rotate it and withdraw it from the manifold.
4. Fit the new valve and 'O' ring seal and set to the previously noted orientation. Reassemble in reverse order.

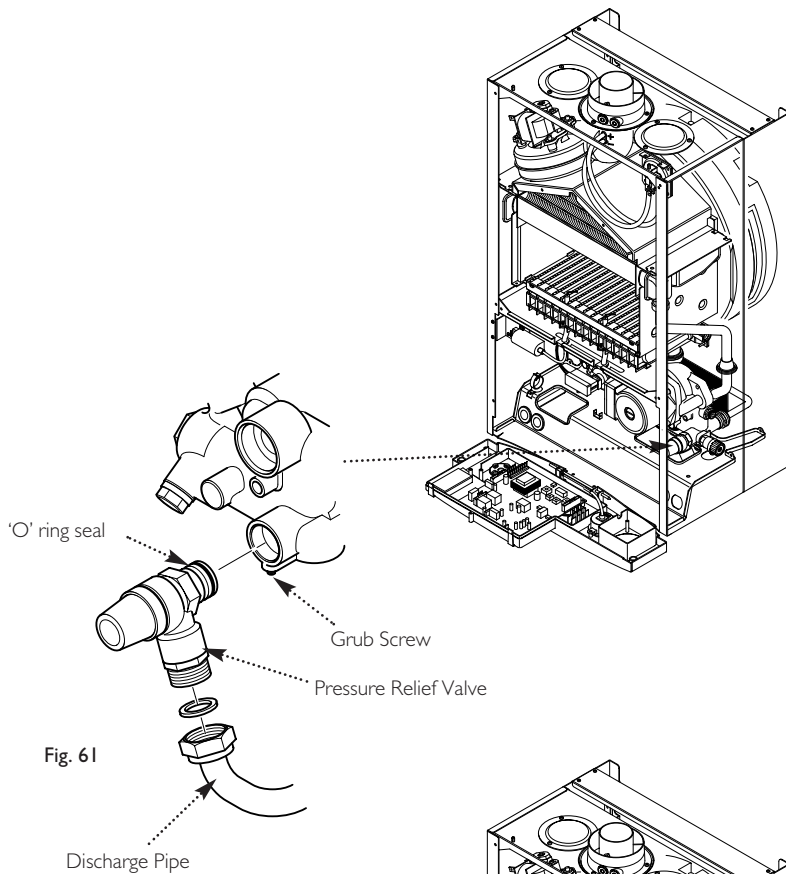

Fig. 61

### 12.19 P.C.B. (Fig. 63)

1. Note the settings of the temperature control knobs. Rotate the knobs fully anticlockwise and carefully pull them off the drive pins.
2. Remove the screws securing the control box cover and release the cover retaining barbs from their slots. Disengage the rear of the cover from the control box hinge pin (Fig. 62).
3. Note the position of all plugs and wires on the P.C.B. and disconnect them.
4. Undo the securing screws and remove the P.C.B. Transfer the control knob drive pins to the new P.C.B. and turn them fully anticlockwise.
5. Reassemble in reverse order, ensuring that the temperature controllers are reset to their previous positions.

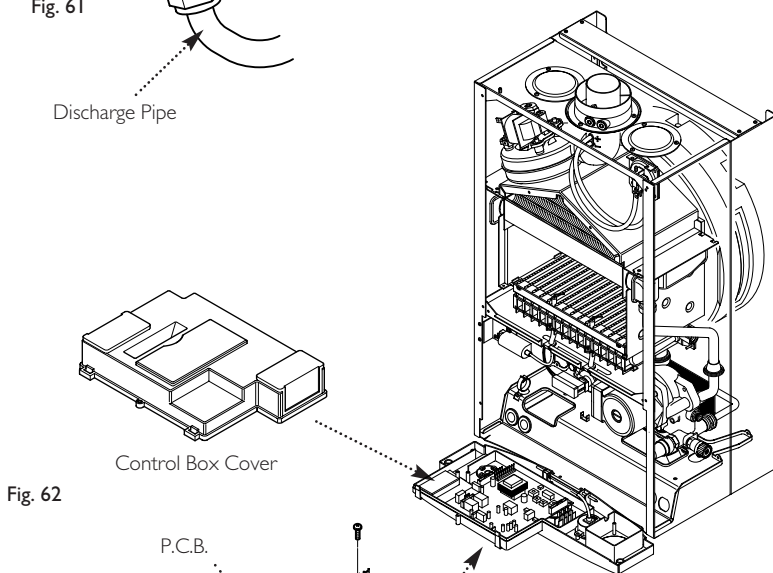

Fig. 62

### 12.20 Selector Switch

1. Turn the selector switch knob to the off position and carefully pull it off the facia.
2. Remove the screws securing the control box cover and release the cover retaining barbs from their slots. Disengage the rear of the cover from the control box hinge pin.
3. Note the position of the electrical connections and the orientation of the switch. Remove the electrical connections.
4. Remove the screws securing the switch to the facia panel.
5. Fit the new switch and reassemble in reverse order. Turn the knob to the required setting.

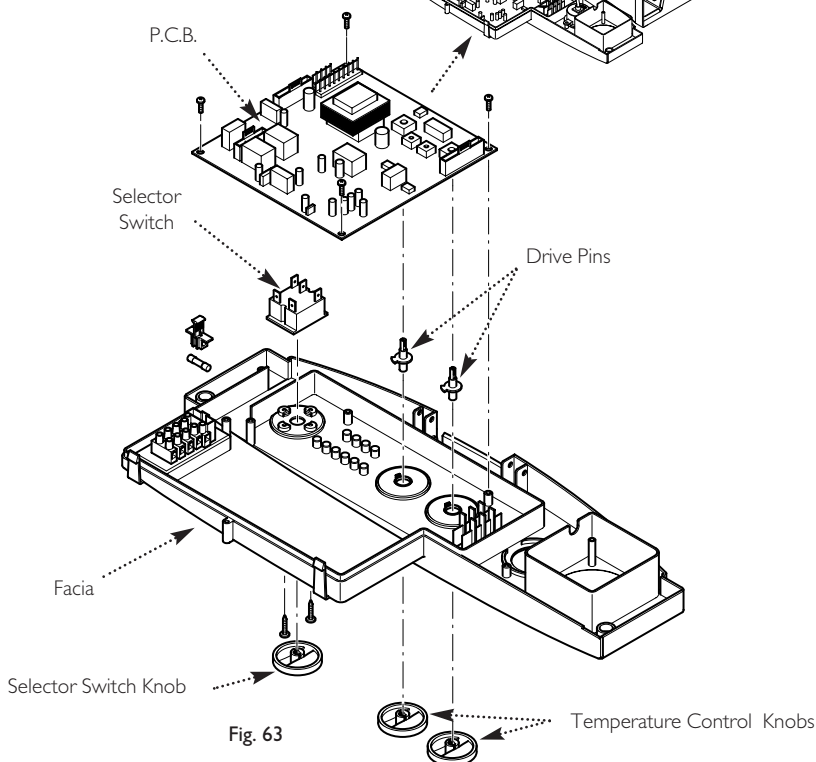

Fig. 63

## 12.0 Changing Components

### 12.21 Plate Heat Exchanger (Fig. 64)

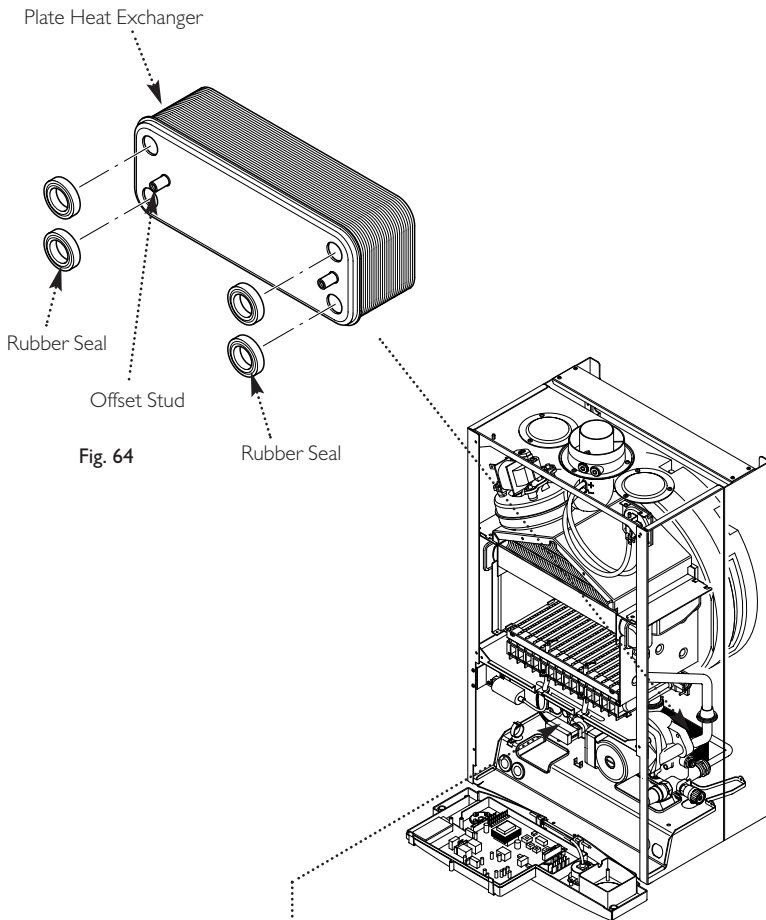

Fig. 64

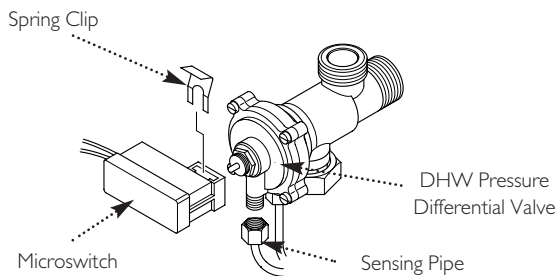

Fig. 65

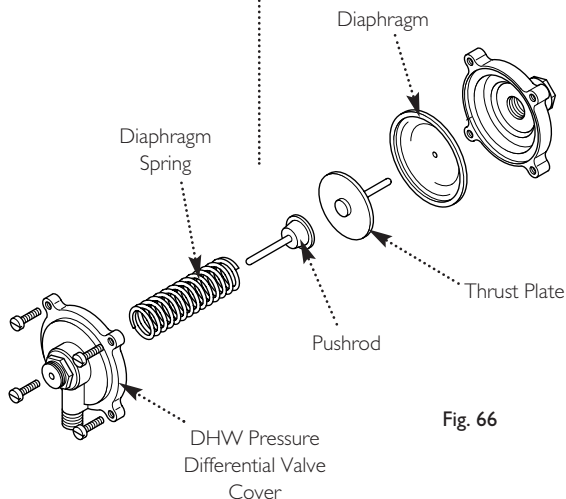

Fig. 66

1. Drain the primary circuit.

2. While supporting the heat exchanger undo the screws securing it to the brass manifolds.

3. Withdraw the heat exchanger upwards and to the left of the gas valve, taking care not to damage any wires or controls.

#### Seals

4. There are four rubber seals between the manifolds and heat exchanger which may require replacement.

5. Ease the seals out of the manifolds. Replace carefully, ensuring that the seal is inserted into the manifold parallel and pushed fully in.

6. When fitting the new heat exchanger note that the left hand location stud is offset towards the centre more than the right hand one.

7. Reassemble in reverse order.

### 12.22 Diverter Valve Assembly (Figs. 65 & 66)

The diverter valve assembly comprises of a central heating pressure differential valve and a domestic hot water pressure differential valve. These are connected to a manifold which is joined to the plate heat exchanger.

#### DHW Pressure Differential Valve Diaphragm (Figs. 65 & 66)

1. Turn off the mains water inlet tap and drain the domestic hot water by turning on a hot tap.

2. Prise off the spring clip retaining the microswitch. Pull the switch away.

3. Undo the sensing pipe nut from the valve and slacken the nut at the inlet manifold. Ease the pipe away from the valve.

4. Undo the screws securing the differential valve cover.

5. Carefully draw off the cover and remove the diaphragm, noting the orientation.

6. Fit the new diaphragm and reassemble in reverse order.

## 12.0 Changing Components

### 12.22 Diverter Valve Assembly (Cont)

#### CH Pressure Differential Valve Diaphragm (Fig. 67)

1. Isolate the boiler from the central heating flow and return pipes and drain the boiler primary circuit.
2. Prise off the spring clip retaining the microswitch. Pull the switch away.
3. Undo the screws securing the differential valve cover.
4. Carefully draw off the cover and remove the diaphragm.
5. Fit the new diaphragm and reassemble in reverse order.

#### Diverter Valve Operating Head (Fig. 67)

1. Pull the 3-pin plug off the operating head and prise off the spring clip retaining the head to the valve body.
2. Lift the operating head away from the valve body.
3. Fit the new head and reassemble in reverse order.

### 12.23 Flow Regulator (Figs. 68 & 69)

1. Undo the filter cartridge from the inlet/return manifold.
2. Unscrew the venturi and remove the flow regulator.
3. Check the cleanliness of the filter gauze, rinsing thoroughly in clean water as necessary. Fit the new flow regulator and reassemble in reverse order.

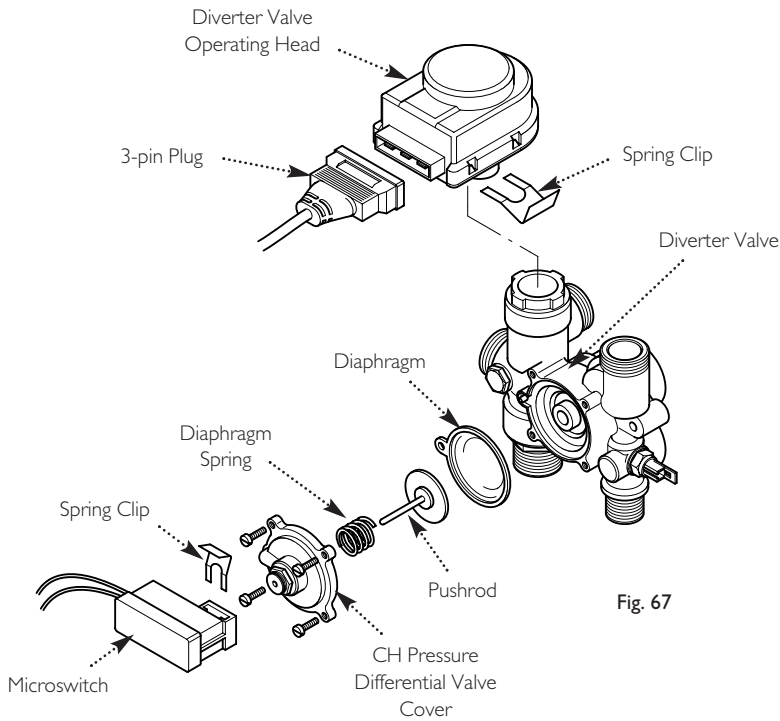

Fig. 67

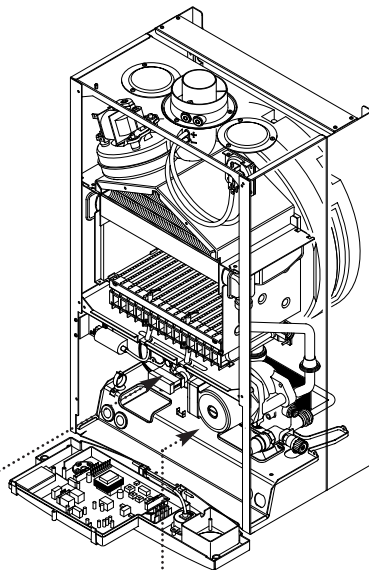

Fig. 69

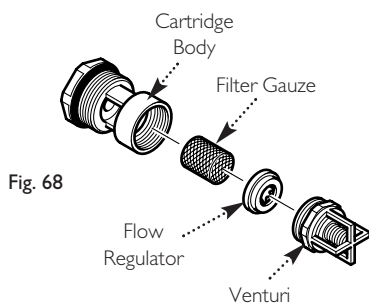
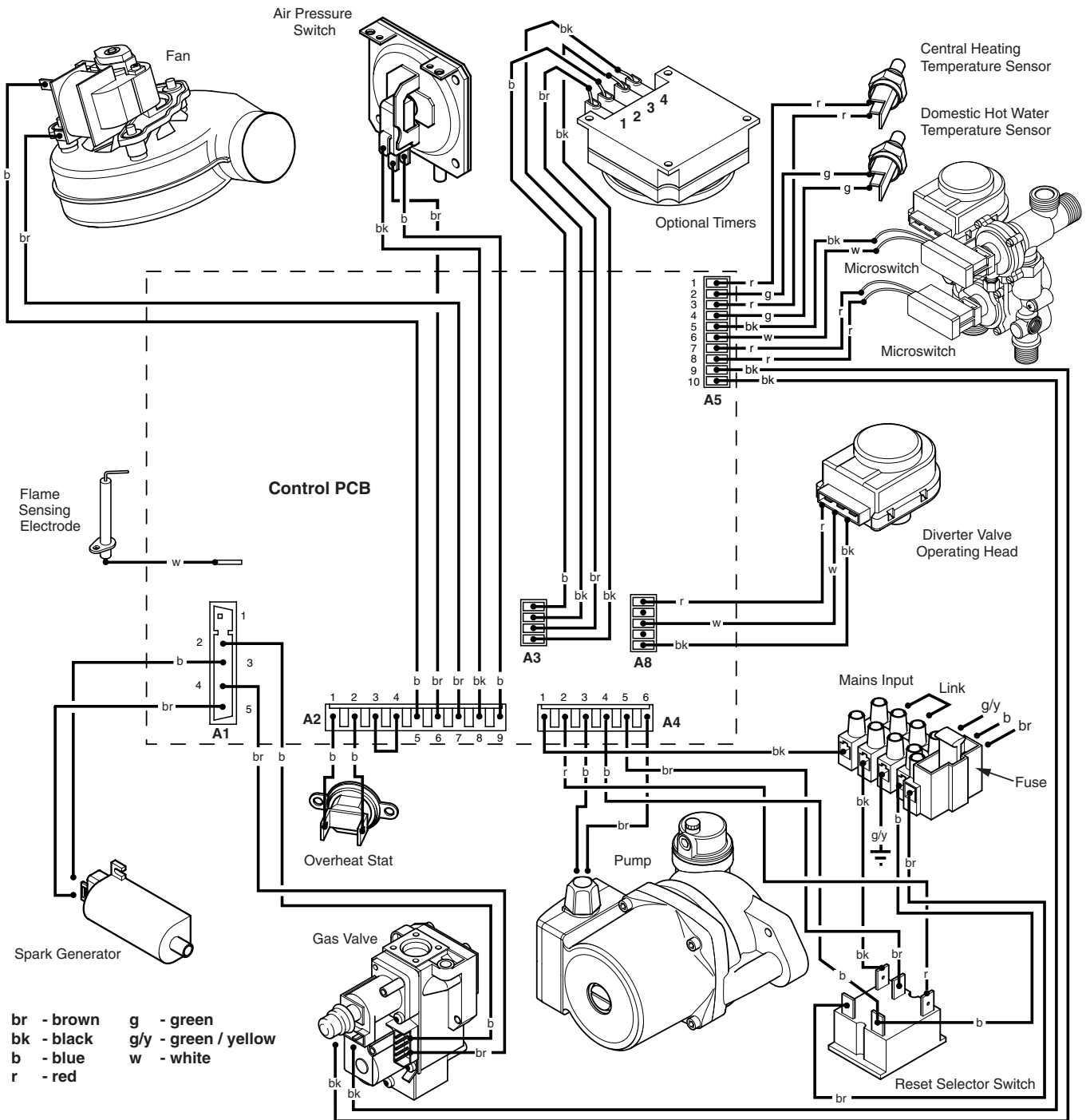

Fig. 68

Inlet/Return Manifold

# 13.0 Illustrated Wiring Diagram





## Carry out initial fault finding checks

- Check that gas, water and electrical supplies are available at the boiler. Electrical supply = 230V ~ 50 Hz.  
CH water system pressurised to 0.5 bar when the boiler is cold. The preferred minimum gas pressure is 19.5mbar (natural gas), 27mbar (butane) or 36mbar (propane).
- Carry out electrical system checks, i.e. Ground Continuity, Resistance to Ground, Short Circuit and Polarity with a suitable meter.  
**NOTE:** These checks must be repeated after any servicing or fault finding.
- Ensure all external controls are calling for heat and check all external and internal fuses. Before any servicing or replacement of parts ensure the gas and electrical supplies are isolated.

Refer to Section 13.0 "Illustrated Wiring Diagram" for position of numbered terminals  
**Domestic Hot Water - Preheating Function - Follow operational sequence**

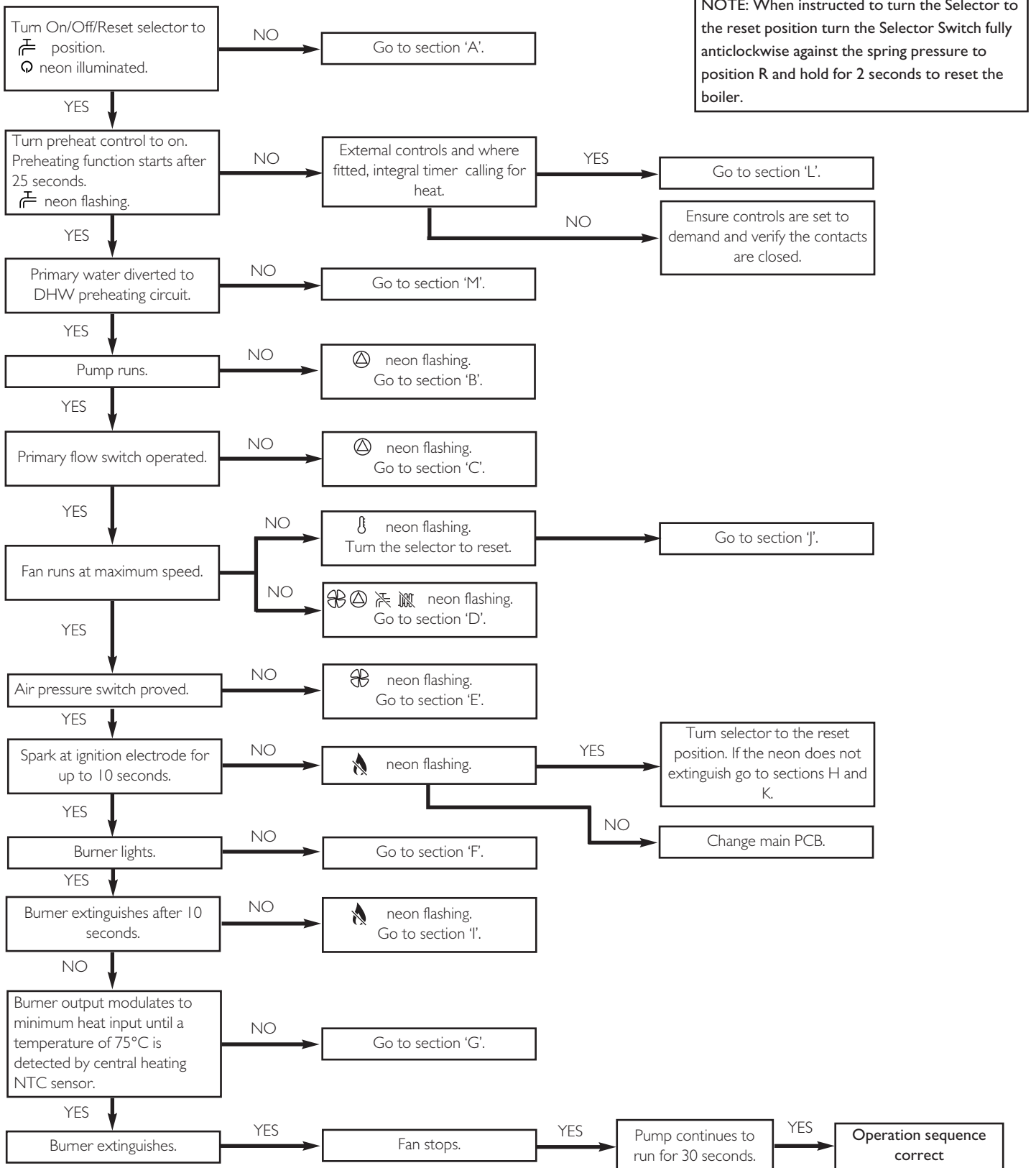

Domestic Hot Water - Follow operational sequence

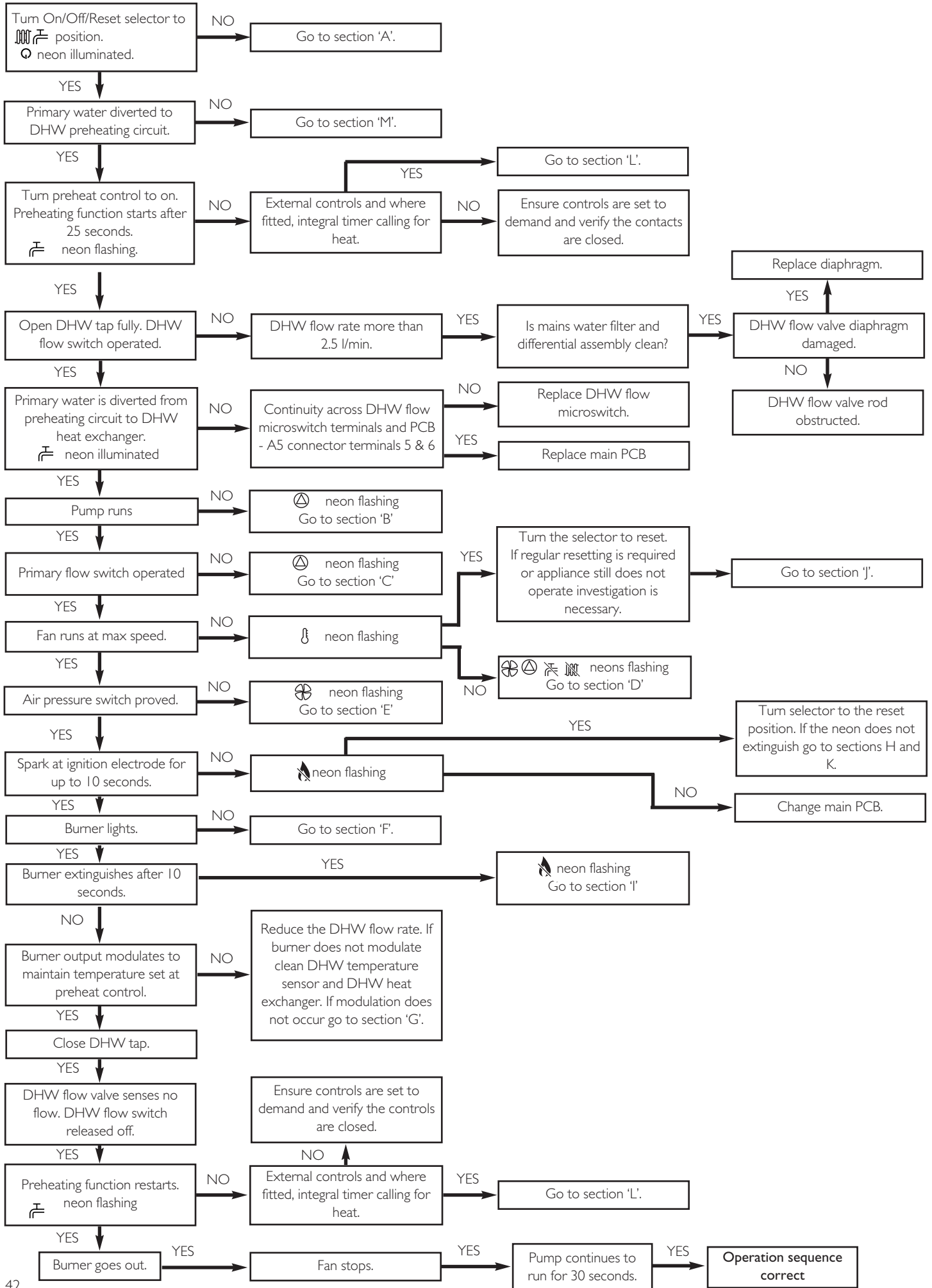

## Central Heating - Follow operational sequence

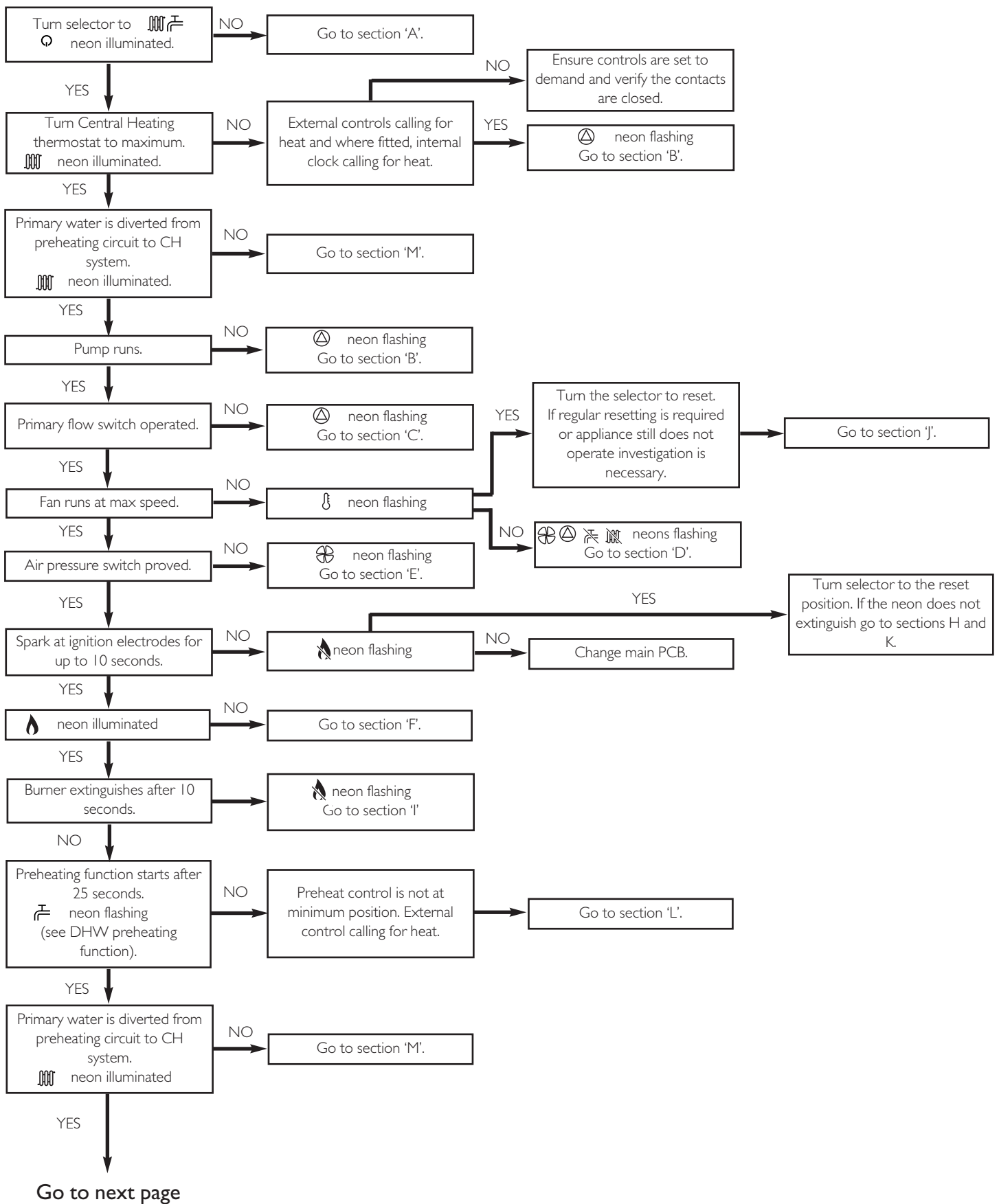

Central Heating - Follow operational sequence (Continued)

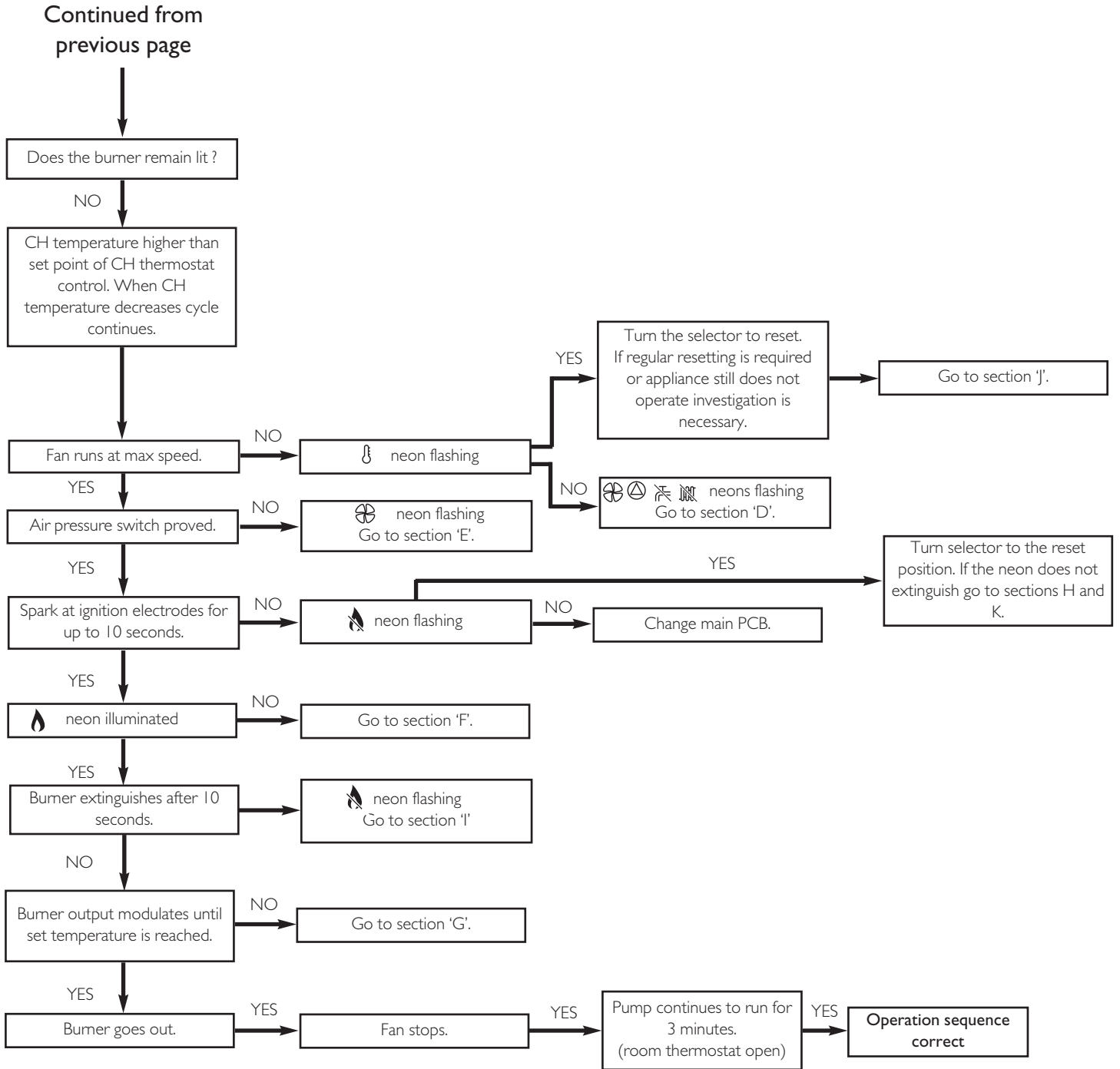

Fault Finding Solutions

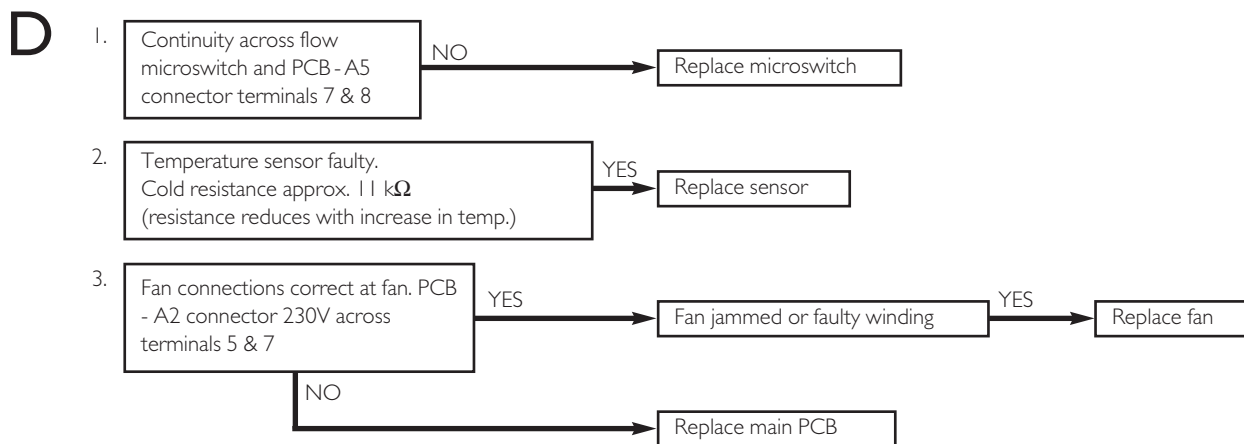
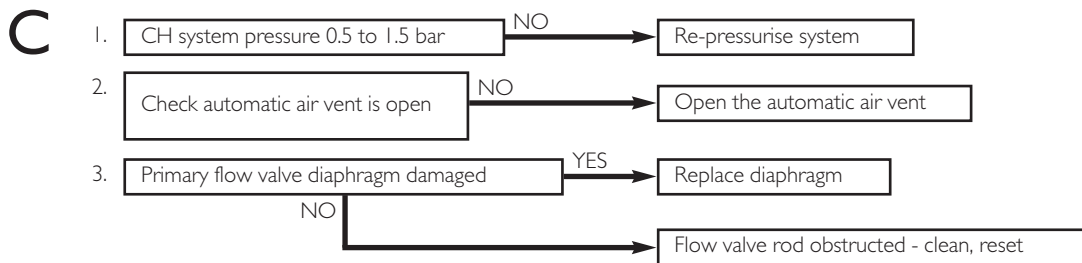
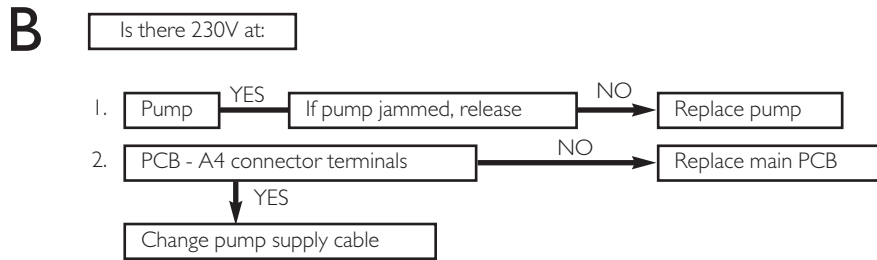
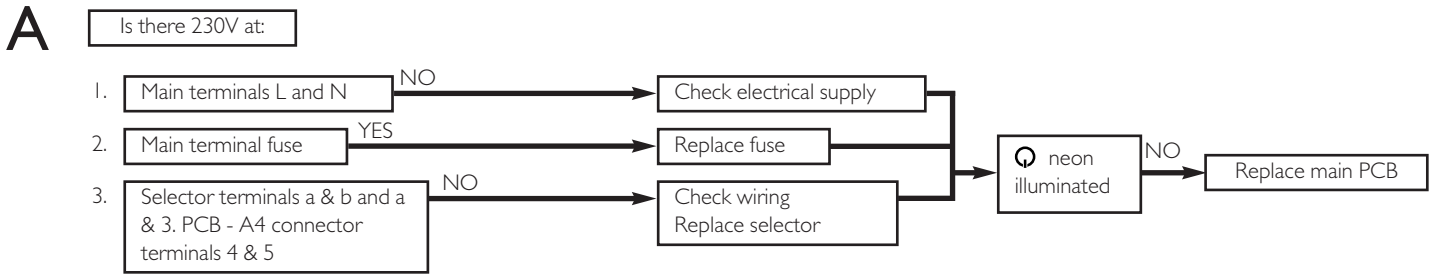

Fault Finding Solutions

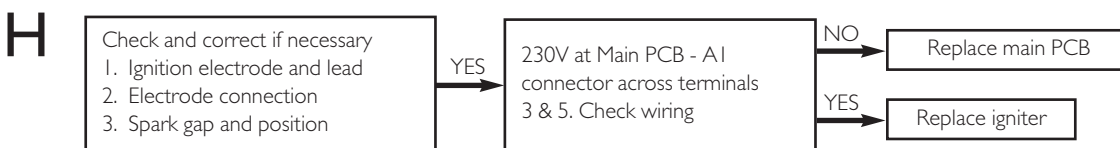
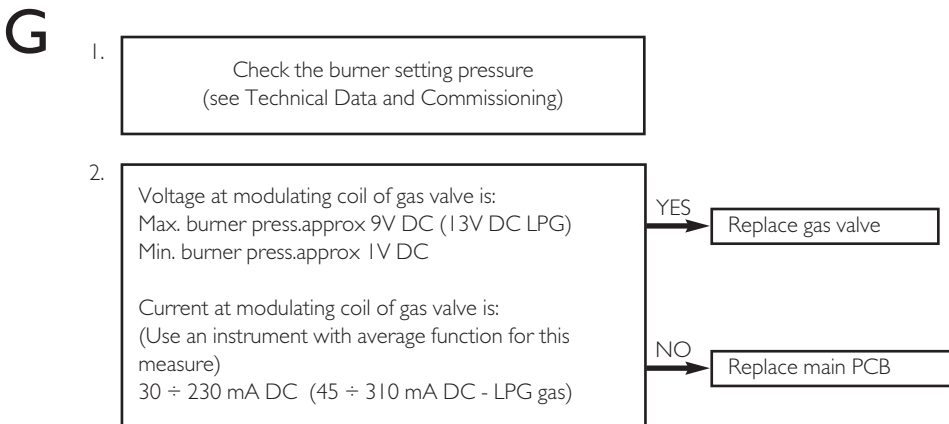
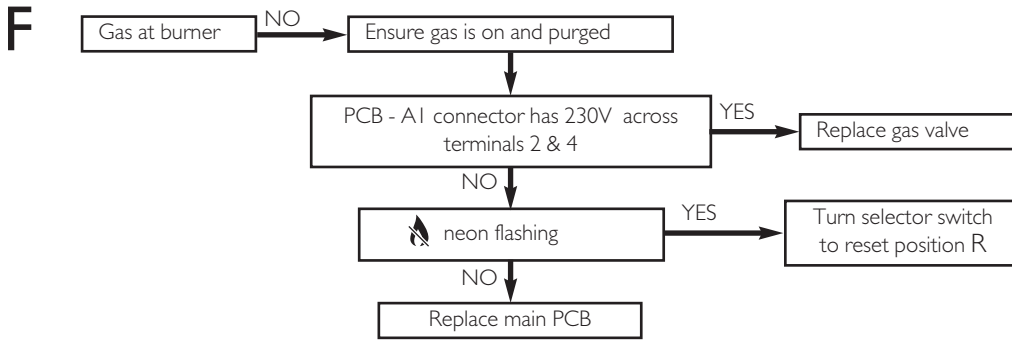
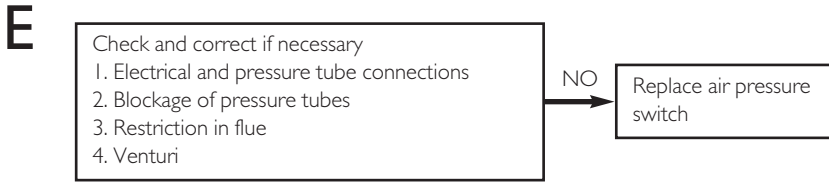

Fault Finding Solutions

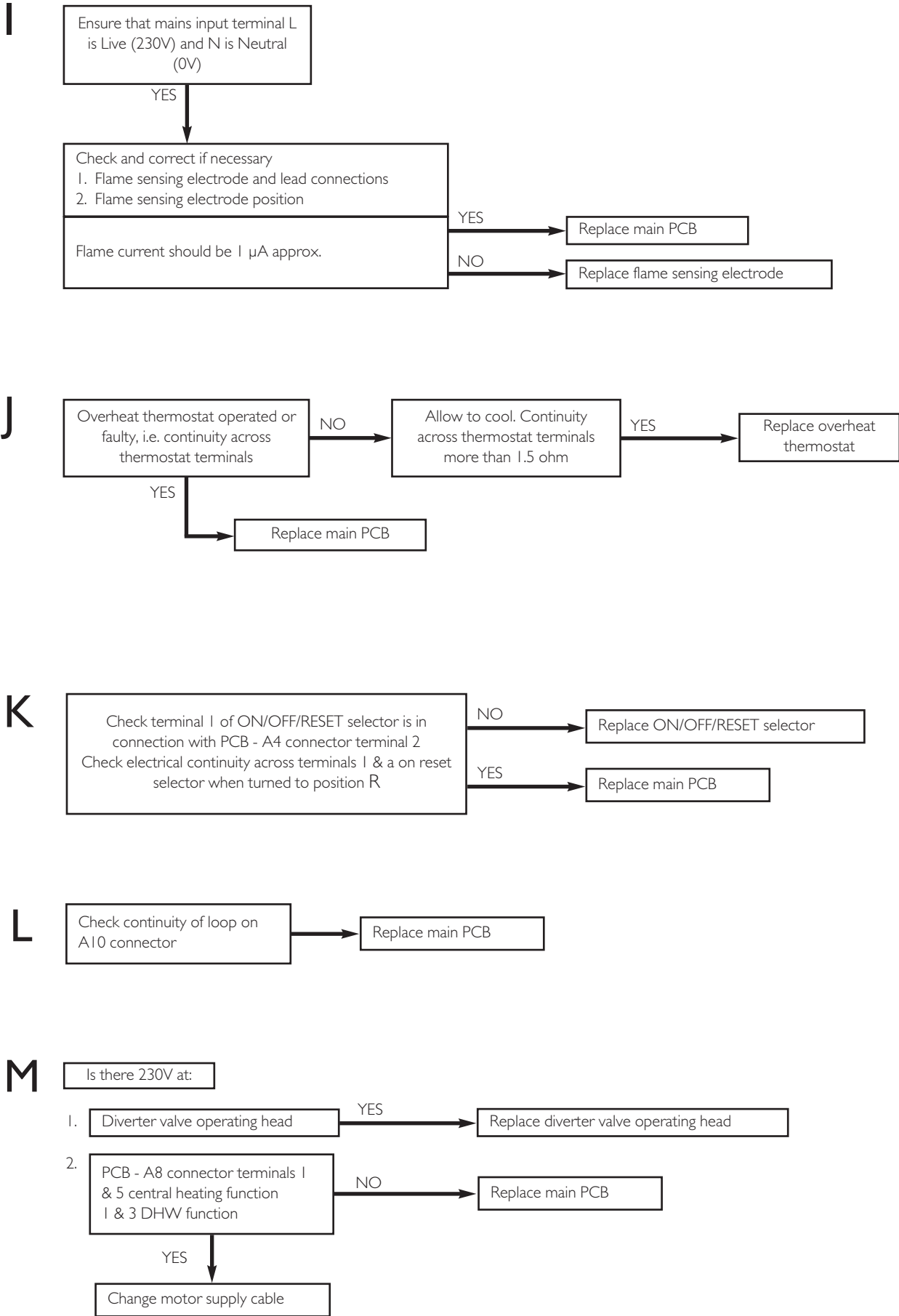

## 15.0 Short Parts List

### Short Parts List

Key No.	G.C. No.	Description	Manufacturers Part No.
22	E66 527	Fan	248002
23	393 974	Pressure Switch	247380
32	E66 393	Heat Exchanger (80e)	248016
	E66 535	Heat Exchanger (105e)	248017
41	E66 398	Burner (80e)	248029
	E66 399	Burner (105e)	248030
44	E66 402	Injector	248210
59	E66 408	Electrode Lead	248037
63	E66 411	Spark or Sensing Electrode	247384
72	E66 431	Pump Complete (80e)	248041
	E66 539	Pump Complete (105e)	248042
131		Temperature Sensor	5108265
135	E66 439	Safety Thermostat	248079
140		Gas Valve	5107339
141		Modulation Coil	5107340
154	E68 347	PCB	248731
169	E66 453	Pressure Gauge	248090
387	E68 349	Motor-3way Valve	248733
390	E68 350	Differential Valve-DHW	248734

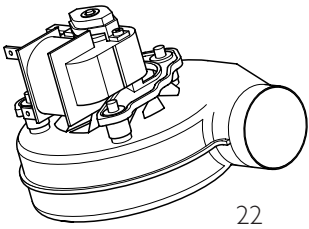

22

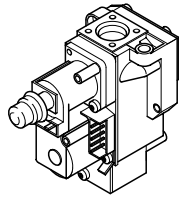

140



44

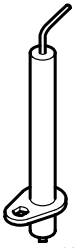

63



131



135

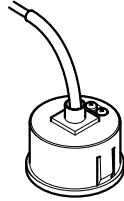

169

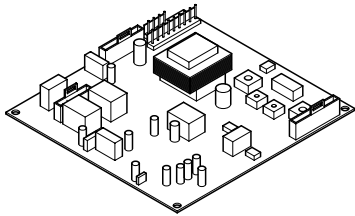

154

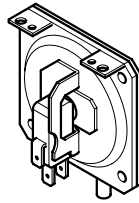

387

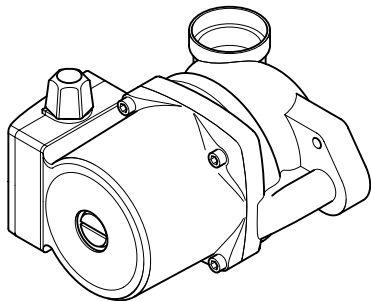

72

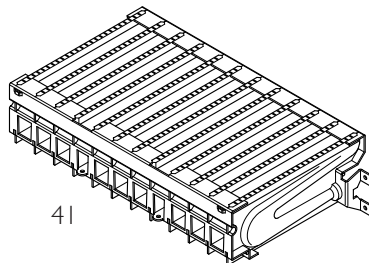

41

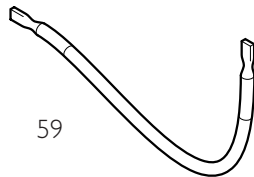

59

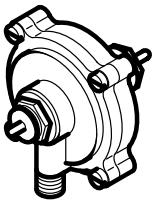

390

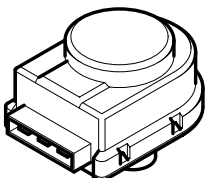

387

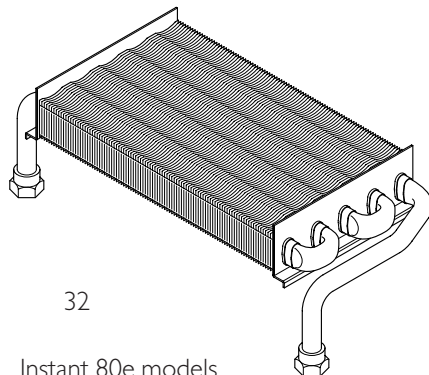

32

Instant 80e models

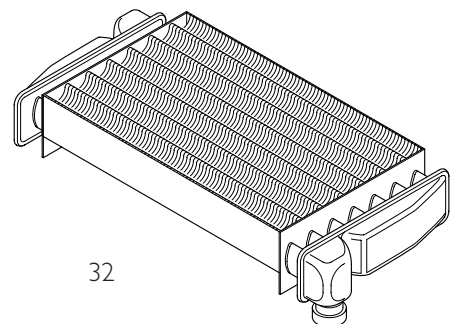

32

Instant 105e models







# GAS BOILER COMMISSIONING CHECKLIST

**BOILER SERIAL No.** \_\_\_\_\_ **NOTIFICATION No.** \_\_\_\_\_

**CONTROLS** To comply with the Building Regulations, each section must have a tick in one or other of the boxes

TIME & TEMPERATURE CONTROL TO HEATING	ROOM T/STAT & PROGRAMMER/TIMER <input type="checkbox"/>	PROGRAMMABLE ROOMSTAT <input type="checkbox"/>
TIME & TEMPERATURE CONTROL TO HOT WATER	CYLINDER T/STAT & PROGRAMMER/TIMER <input type="checkbox"/>	COMBI BOILER <input type="checkbox"/>
HEATING ZONE VALVES	FITTED <input type="checkbox"/>	NOT REQUIRED <input type="checkbox"/>
HOT WATER ZONE VALVES	FITTED <input type="checkbox"/>	NOT REQUIRED <input type="checkbox"/>
THERMOSTATIC RADIATOR VALVES	FITTED <input type="checkbox"/>	
AUTOMATIC BYPASS TO SYSTEM	FITTED <input type="checkbox"/>	NOT REQUIRED <input type="checkbox"/>

### FOR ALL BOILERS CONFIRM THE FOLLOWING

THE SYSTEM HAS BEEN FLUSHED IN ACCORDANCE WITH THE BOILER MANUFACTURER'S INSTRUCTIONS?

THE SYSTEM CLEANER USED \_\_\_\_\_

THE INHIBITOR USED \_\_\_\_\_

### FOR THE CENTRAL HEATING MODE, MEASURE & RECORD

GAS RATE  m<sup>3</sup>/hr  ft<sup>3</sup>/hr

BURNER OPERATING PRESSURE (IF APPLICABLE)  N/A  mbar

CENTRAL HEATING FLOW TEMPERATURE  °C

CENTRAL HEATING RETURN TEMPERATURE  °C

### FOR COMBINATION BOILERS ONLY

HAS A WATER SCALE REDUCER BEEN FITTED? YES  NO

WHAT TYPE OF SCALE REDUCER HAS BEEN FITTED? \_\_\_\_\_

### FOR THE DOMESTIC HOT WATER MODE, MEASURE & RECORD

GAS RATE  m<sup>3</sup>/hr  ft<sup>3</sup>/hr

MAXIMUM BURNER OPERATING PRESSURE (IF APPLICABLE)  N/A  mbar

COLD WATER INLET TEMPERATURE  °C

HOT WATER OUTLET TEMPERATURE  °C

WATER FLOW RATE  lts/min

### FOR CONDENSING BOILERS ONLY CONFIRM THE FOLLOWING

THE CONDENSATE DRAIN HAS BEEN INSTALLED IN ACCORDANCE WITH THE MANUFACTURER'S INSTRUCTIONS? YES

### FOR ALL INSTALLATIONS CONFIRM THE FOLLOWING

THE HEATING AND HOT WATER SYSTEM COMPLIES WITH CURRENT BUILDING REGULATIONS

THE APPLIANCE AND ASSOCIATED EQUIPMENT HAS BEEN INSTALLED AND COMMISSIONED IN ACCORDANCE WITH THE MANUFACTURER'S INSTRUCTIONS

IF REQUIRED BY THE MANUFACTURER, HAVE YOU RECORDED A CO/CO<sub>2</sub> RATIO READING? N/A  YES  CO/CO<sub>2</sub> RATIO

THE OPERATION OF THE APPLIANCE AND SYSTEM CONTROLS HAVE BEEN DEMONSTRATED TO THE CUSTOMER

THE MANUFACTURER'S LITERATURE HAS BEEN LEFT WITH THE CUSTOMER

**COMMISSIONING ENG'S NAME** PRINT \_\_\_\_\_ CORGI ID No. \_\_\_\_\_

SIGN \_\_\_\_\_ DATE \_\_\_\_\_

# SERVICE INTERVAL RECORD

It is recommended that your heating system is serviced regularly and that you complete the appropriate Service Interval Record Below.

**Service Provider.** Before completing the appropriate Service Interval Record below, please ensure you have carried out the service as described in the boiler manufacturer's instructions. Always use the manufacturer's specified spare part when replacing all controls

## SERVICE 1 DATE

ENGINEER NAME \_\_\_\_\_  
COMPANY NAME \_\_\_\_\_  
TEL No. \_\_\_\_\_  
CORGI ID CARD SERIAL No. \_\_\_\_\_  
COMMENTS \_\_\_\_\_  
SIGNATURE \_\_\_\_\_

## SERVICE 2 DATE

ENGINEER NAME \_\_\_\_\_  
COMPANY NAME \_\_\_\_\_  
TEL No. \_\_\_\_\_  
CORGI ID CARD SERIAL No. \_\_\_\_\_  
COMMENTS \_\_\_\_\_  
SIGNATURE \_\_\_\_\_

## SERVICE 3 DATE

ENGINEER NAME \_\_\_\_\_  
COMPANY NAME \_\_\_\_\_  
TEL No. \_\_\_\_\_  
CORGI ID CARD SERIAL No. \_\_\_\_\_  
COMMENTS \_\_\_\_\_  
SIGNATURE \_\_\_\_\_

## SERVICE 4 DATE

ENGINEER NAME \_\_\_\_\_  
COMPANY NAME \_\_\_\_\_  
TEL No. \_\_\_\_\_  
CORGI ID CARD SERIAL No. \_\_\_\_\_  
COMMENTS \_\_\_\_\_  
SIGNATURE \_\_\_\_\_

## SERVICE 5 DATE

ENGINEER NAME \_\_\_\_\_  
COMPANY NAME \_\_\_\_\_  
TEL No. \_\_\_\_\_  
CORGI ID CARD SERIAL No. \_\_\_\_\_  
COMMENTS \_\_\_\_\_  
SIGNATURE \_\_\_\_\_

## SERVICE 6 DATE

ENGINEER NAME \_\_\_\_\_  
COMPANY NAME \_\_\_\_\_  
TEL No. \_\_\_\_\_  
CORGI ID CARD SERIAL No. \_\_\_\_\_  
COMMENTS \_\_\_\_\_  
SIGNATURE \_\_\_\_\_

## SERVICE 7 DATE

ENGINEER NAME \_\_\_\_\_  
COMPANY NAME \_\_\_\_\_  
TEL No. \_\_\_\_\_  
CORGI ID CARD SERIAL No. \_\_\_\_\_  
COMMENTS \_\_\_\_\_  
SIGNATURE \_\_\_\_\_

## SERVICE 8 DATE

ENGINEER NAME \_\_\_\_\_  
COMPANY NAME \_\_\_\_\_  
TEL No. \_\_\_\_\_  
CORGI ID CARD SERIAL No. \_\_\_\_\_  
COMMENTS \_\_\_\_\_  
SIGNATURE \_\_\_\_\_

## SERVICE 9 DATE

ENGINEER NAME \_\_\_\_\_  
COMPANY NAME \_\_\_\_\_  
TEL No. \_\_\_\_\_  
CORGI ID CARD SERIAL No. \_\_\_\_\_  
COMMENTS \_\_\_\_\_  
SIGNATURE \_\_\_\_\_

## SERVICE 10 DATE

ENGINEER NAME \_\_\_\_\_  
COMPANY NAME \_\_\_\_\_  
TEL No. \_\_\_\_\_  
CORGI ID CARD SERIAL No. \_\_\_\_\_  
COMMENTS \_\_\_\_\_  
SIGNATURE \_\_\_\_\_

**BAXI POTTERTON**

A Trading Division of Baxi Heating UK Ltd

Brownedge Road Bamber Bridge Preston Lancashire PR5 6UP

After Sales Service 08706 096 096 Technical Enquiries 08706 049 049

Website [www.baxi.co.uk](http://www.baxi.co.uk)

A BAXI GR●UP company

922.555.3

Comp N° 248741 - Iss 7 - 4/05