



**Installation and Service Manual**  
**Air/water "Split Inverter" heat pump**

**Baxi Assure**  
**Assure AWHP-IDU 4-8 E**

# Contents

- 1 Safety instructions and recommendations ..... 5**
  - 1.1 Safety ..... 5
  - 1.2 General instructions ..... 6
  - 1.3 Electrical safety ..... 6
  - 1.4 Refrigerant safety ..... 7
  - 1.5 Domestic water safety ..... 7
  - 1.6 Hydraulic safety ..... 8
  - 1.7 Recommendations for the installation ..... 8
  - 1.8 Specific instructions for service, maintenance and breakdowns ..... 8
  - 1.9 Liabilities ..... 9
- 2 Symbols used ..... 10**
  - 2.1 Symbols used in the manual ..... 10
  - 2.2 Symbols used on the appliance ..... 10
  - 2.3 Symbols used on the data plate ..... 10
- 3 Technical specifications ..... 11**
  - 3.1 Homologations ..... 11
    - 3.1.1 Directives ..... 11
    - 3.1.2 EC Declaration of Conformity ..... 11
    - 3.1.3 Factory test ..... 11
  - 3.2 Technical data ..... 11
    - 3.2.1 Compatible heating devices ..... 11
    - 3.2.2 Heat pump ..... 11
    - 3.2.3 Heat pump weight ..... 12
    - 3.2.4 Combination heaters with medium-temperature heat pump ..... 13
    - 3.2.5 Sensor specifications ..... 14
    - 3.2.6 Circulating pumps ..... 14
  - 3.3 Dimensions and connections ..... 15
    - 3.3.1 Indoor unit ..... 15
    - 3.3.2 AWHP 4.5 MR outdoor unit ..... 16
    - 3.3.3 AWHP 6 MR-3 outdoor unit ..... 16
    - 3.3.4 AWHP 8 MR-2 outdoor unit ..... 17
  - 3.4 Electrical diagram ..... 18
- 4 Description of the product ..... 20**
  - 4.1 Operating principle ..... 20
  - 4.2 Main components ..... 20
  - 4.3 Standard delivery ..... 21
- 5 Connecting diagrams and configuration ..... 22**
  - 5.1 Installation with electrical back-up, two circuits and a domestic hot water tank ..... 22
    - 5.1.1 Make the electrical connections ..... 22
    - 5.1.2 Applying the parameters ..... 23
  - 5.2 Connecting a swimming pool ..... 24
- 6 Installation ..... 26**
  - 6.1 Installation regulations ..... 26
  - 6.2 Data Plates ..... 26
    - 6.2.1 Data plate on the indoor module ..... 26
    - 6.2.2 Data plate on the outdoor unit ..... 26
  - 6.3 Respecting the distance between the indoor module and the outdoor unit ..... 26
  - 6.4 Positioning the indoor unit ..... 27
    - 6.4.1 Allowing sufficient space for the indoor module ..... 27
    - 6.4.2 Fitting the assembly rail ..... 28
    - 6.4.3 Mounting the unit on the wall ..... 28
  - 6.5 Putting the outdoor unit in place ..... 28
    - 6.5.1 Allowing sufficient space for the outdoor unit ..... 28
    - 6.5.2 Selecting the location of the outdoor unit ..... 29
    - 6.5.3 Choosing the location of a noise abatement screen ..... 30
    - 6.5.4 Selecting the location of the outdoor unit in cold and snowy regions ..... 30
    - 6.5.5 Installing the outdoor unit on the ground ..... 31
  - 6.6 Hydraulic connections ..... 31
    - 6.6.1 Special precautions for the connection of the heating circuit ..... 31





6.6.2	Connecting the heating circuit . . . . .	31
6.6.3	Connecting the safety valve drain pipe . . . . .	32
6.7	Refrigeration connections . . . . .	32
6.7.1	Preparing the refrigerant connections . . . . .	32
6.7.2	Connect the refrigerant connections to the indoor unit . . . . .	33
6.7.3	Connecting the refrigerant connections to the outdoor unit . . . . .	34
6.7.4	Adding the necessary quantity of refrigerant fluid . . . . .	34
6.7.5	Testing the leak-tightness of the refrigerant connections . . . . .	35
6.7.6	Evacuation . . . . .	35
6.7.7	Opening the stop valves . . . . .	36
6.8	Electrical connections . . . . .	36
6.8.1	Recommendations . . . . .	36
6.8.2	Recommended cable cross section . . . . .	37
6.8.3	Routing the cables . . . . .	38
6.8.4	Description of the connection terminal blocks . . . . .	38
6.8.5	Accessing the PCBs . . . . .	41
6.8.6	Connecting the cables to the PCBs . . . . .	42
6.8.7	Electrically connecting the outdoor unit . . . . .	43
6.8.8	Connecting the indoor module . . . . .	44
6.8.9	Connecting the outdoor unit bus . . . . .	45
6.8.10	Fitting the outdoor sensor . . . . .	45
6.8.11	Connecting the outdoor temperature sensor . . . . .	46
6.8.12	Connecting and configuring the electrical back-up . . . . .	47
6.9	Connecting options . . . . .	48
6.9.1	Connecting an on/off or modulating thermostat . . . . .	49
6.9.2	Configuring a thermostat with a heating/cooling control contact . . . . .	49
6.10	Filling the heating circuit . . . . .	51
6.10.1	Flushing new installations and installations less than 6 months old . . . . .	51
6.10.2	Flushing an existing installation . . . . .	51
6.11	Filling the installation . . . . .	51
6.11.1	Treatment of the heating water . . . . .	51
<b>7</b>	<b>Commissioning . . . . .</b>	<b>53</b>
7.1	General . . . . .	53
7.2	Checklist before commissioning . . . . .	53
7.2.1	Checking the heating circuit . . . . .	53
7.2.2	Checking the electrical connections . . . . .	53
7.2.3	Checking the refrigeration circuit . . . . .	53
7.3	Commissioning procedure . . . . .	54
7.3.1	Configuration numbers <b>CN1 et CN2</b> . . . . .	54
7.4	Final instructions for commissioning . . . . .	54
<b>8</b>	<b>Operation . . . . .</b>	<b>56</b>
8.1	Use of the control panel . . . . .	56
8.1.1	Description of the user interface . . . . .	56
8.1.2	Description of the home screen . . . . .	56
8.2	Starting and stopping the heat pump . . . . .	57
8.2.1	Starting the heat pump . . . . .	57
8.2.2	Shutting down the heat pump . . . . .	57
<b>9</b>	<b>Settings . . . . .</b>	<b>58</b>
9.1	Accessing the Installer level . . . . .	58
9.2	Setting the parameters . . . . .	58
9.2.1	Setting the heating curve . . . . .	58
9.2.2	Saving the installer details . . . . .	58
9.2.3	Saving the commissioning settings . . . . .	58
9.2.4	Resetting or re-establishing the parameters . . . . .	59
9.2.5	Improving heating comfort . . . . .	59
9.2.6	Improving domestic hot water comfort . . . . .	60
9.2.7	Drying screed with an outdoor unit connected . . . . .	60
9.2.8	Drying screed without the heat pump outdoor unit . . . . .	61
9.2.9	Installing a buffer tank . . . . .	62
9.2.10	Configuring the buffer tank for storage . . . . .	63
9.2.11	Configuring and using the CB04 auto-filling option kit . . . . .	65
9.2.12	Supplying the heat pump with photovoltaic energy . . . . .	66
9.2.13	Reducing the noise level of the outdoor unit . . . . .	67

9.3	Menu tree 	67
9.4	List of parameters	67
9.4.1	Installation Setup > <b>CIRCA0</b> > Parameters, counters, signals	67
9.4.2	Installation Setup > Stratified DHW tank > Parameters, counters, signals	68
9.4.3	Installation Setup > <b>CIRCA1/CIRCB1/DHW1/CIRCC1/CIRCAUX1</b> > Parameters, counters, signals >	69
9.4.4	Installation Setup > Air Src heat pump > Parameters, counters, signals	71
9.4.5	Installation Setup > <b>Cascade management B</b> > Parameters, counters, signals	73
9.4.6	Installation Setup > <b>Outside temp</b> > Parameters, counters, signals	74
9.4.7	Installation Setup > <b>Digital input</b> > Parameters, counters, signals	74
9.4.8	Installation Setup > <b>Analogue input</b> > Parameters, counters, signals	75
9.4.9	Installation Setup > <b>0-10 V input</b> > Parameters, counters, signals	75
9.4.10	Installation Setup > <b>Appliance status</b> > Parameters, counters, signals	76
9.5	Description of the parameters	76
9.5.1	Running the back-up in heating mode	76
9.5.2	Running the back-up in domestic hot water mode	78
9.5.3	Operation of the switch between heating and production of domestic hot water	80
<b>10</b>	<b>Maintenance</b>	<b>82</b>
10.1	Accessing information on the hardware and software versions	82
10.2	Configuring the maintenance message	82
10.3	Checking operation of the appliance	82
10.4	Standard inspection and maintenance operations	83
10.4.1	Checking the safety components	83
10.4.2	Check the hydraulic pressure	83
10.4.3	Cleaning the casing	83
10.5	Cleaning the magnetic filter	83
10.5.1	Magnetic filter annual maintenance	84
10.5.2	Full cleaning of the magnetic filter	85
10.6	Specific maintenance operations	87
10.6.1	Draining the heating circuit	87
10.6.2	Replacing the battery in the control panel	87
<b>11</b>	<b>Troubleshooting</b>	<b>88</b>
11.1	Resetting the safety thermostat	88
11.2	Resolving operating errors	88
11.2.1	Types of error code	88
11.2.2	Error codes	88
11.2.3	SCB-10 error codes	91
11.2.4	Fault codes	93
11.2.5	EHC-05 alarm codes	93
11.2.6	SCB-10 alarm codes	94
11.3	Displaying and clearing the error memory	94
<b>12</b>	<b>Decommissioning and disposal</b>	<b>95</b>
12.1	Decommissioning procedure	95
12.2	Disposal and recycling	95
<b>13</b>	<b>Spare parts</b>	<b>96</b>
13.1	General	96
13.2	Indoor unit	96
13.2.1	Casing	96
13.2.2	Control system	97
13.2.3	Other components	99
13.3	Outdoor unit	102
13.3.1	AWHP 4.5 MR	102
13.3.2	AWHP 6 MR-3	103
13.3.3	AWHP 8 MR-2	106
<b>14</b>	<b>Reference</b>	<b>109</b>

# 1 Safety instructions and recommendations

## 1.1 Safety

Operation	<p> <b>Danger</b>  This appliance can be used by children aged from 8 years and above and persons with reduced physical, sensory or mental capabilities or lack of experience and knowledge if they have been given supervision or instruction concerning use of the appliance in a safe way and understand the hazards involved. Children shall not play with the appliance. Cleaning and user maintenance shall not be made by children without supervision.</p>
Electrical	<p>The appliance is intended to be permanently connected to the domestic water mains network.  Before any work on the appliance, carefully read all documents that accompany the product. These documents are also available on our website. See the last page.  Install the appliance in accordance with national rules on electrical installation. A disconnection device must be fitted to the fixed wiring in accordance with installation rules.  If a power supply cable comes with the appliance and it turns out to be damaged, it must be replaced by the manufacturer, its after sales service or persons with similar qualifications in order to obviate any danger.  If the appliance is not wired in the factory, carry out the wiring according to the wiring diagram described in the chapter Electrical Connections. See the Installation and Service Manual.  This appliance must be connected to the protective earthing.  Earthing must comply with the prevailing installation standards.  Earth the appliance before making any electrical connections.  Type and calibre of the protective equipment: refer to the "Recommended cable cross-sections" chapter. See the Installation and Service Manual.  To connect the appliance to the electricity mains, refer to the chapter Electrical Connections. See the Installation and Service Manual.  In order to prevent any danger owing to the unexpected reset of the thermal circuit breaker, this appliance must not be powered through an external switch, such as a timer, or be connected to a circuit which is regularly switched on and off by the electricity provider.</p>

<p>Domestic water</p>	<p> <b>Caution</b>                  Draining the domestic hot water tank:</p> <ol style="list-style-type: none"> <li>1. Shut off the domestic cold water inlet.</li> <li>2. Open a hot water tap in the installation.</li> <li>3. Open a valve on the safety unit.</li> <li>4. When the water stops flowing, the domestic hot water tank has been drained.</li> </ol> <p> <b>Caution</b></p> <ul style="list-style-type: none"> <li>• The pressure limiter device (safety valve or safety unit) must be regularly operated in order to remove limescale deposits and ensure that it is not blocked.</li> <li>• A pressure limiter device must be fitted to a discharge pipe.</li> <li>• As water may flow out of the discharge pipe on the pressure limiter device, the pipe must be kept open to the air, in a frost-free environment, and at a continuous downward gradient.</li> <li>• A pressure reducer (not provided) is required when the supply pressure exceeds 80% of the pressure limiter device calibration and must be located upstream of the appliance.</li> <li>• There must be no cut-off devices between the pressure limiter device and the domestic hot water tank.</li> </ul> <p>To ascertain the type, specifications and connection of the pressure limiter device, refer to the chapter Connecting the Domestic Hot Water Tank to the Drinking Water Mains in the Installation and Service Manual.</p>
<p>Hydraulics</p>	<p> <b>Caution</b>                  Respect the minimum and maximum water pressure and temperature to ensure the appliance operates correctly. See chapter on Technical Specifications.</p>
<p>Installation</p>	<p> <b>Important</b>                  Allow the space required to install the appliance correctly, referring to the chapter Dimensions of the Appliance. See the Installation and Service Manual.</p>

## 1.2 General instructions

The system must satisfy each point in the rules in force in the country that govern works and interventions in individual homes, blocks of flats or other buildings.

Only qualified professionals are authorised to work on the appliance and the heating installation. They must respect prevailing local and national regulations during fitting, installation and maintenance of the installation.

Commissioning must be performed by a qualified professional.

## 1.3 Electrical safety

Before making any electrical connections, earth the appliance in accordance with prevailing standards.

**Danger**

Danger of electric shock: the length of the conductors between the traction arrester device and the terminal blocks must be such that the active conductors are put under tension before the earth conductor.

Only qualified professionals may carry out electrical connections, always with the power off.

Separate the very low voltage cables from the 230/400 V power supply cables.

## 1.4 Refrigerant safety

**Warning**

Refrigerant fluid and pipes:

- Use only **R410A** refrigerant fluid to fill the installation.
- Use tools and pipe components especially designed for use with **R410A** refrigerant fluid.
- Use copper pipes deoxidised with phosphorus to carry the refrigerant fluid.
- Store the refrigerant connection pipes away from dust and humidity (risk of damage to the compressor).
- Do not use a load cylinder.
- Protect the heat pump components, including the insulation and structural elements. Do not overheat the pipes as brazed components may cause damage.
- Contact between the refrigerant fluid and a flame may result in emissions of toxic gases.

All work on the refrigeration circuit must be done by a qualified professional, according to prevailing codes of practice and safety in the profession (recovery of the refrigerant, brazing under nitrogen). All brazing work must be done by qualified welders.

Do not touch the refrigeration connection pipes with your bare hands while the heat pump is running. Danger of burn or frost injury.

In the event of a refrigerant leakage:

1. Switch off the appliance.
2. Open the windows.
3. Do not use a naked flame, do not smoke, do not operate electrical contacts.
4. Avoid contact with the refrigerant. Danger of frost injuries.

Locate the probable leak and seal it immediately. Use only original parts to replace a defective refrigeration component.

Use only dehydrated nitrogen for detecting leaks or for pressurised tests.

Do not allow the refrigerant fluid to escape into the atmosphere.

## 1.5 Domestic water safety

In accordance with safety rules, a safety valve calibrated to 0.7 MPa (7 bar) is mounted on the tank's domestic cold water inlet.

A pressure reducer (not provided) is required when the supply pressure exceeds 80% of the safety valve or safety unit calibration and must be located upstream of the appliance.

There must be no cut-off devices between the safety valve or unit and the domestic hot water tank.

The hydraulic installation must be capable of handling a minimum flow rate at all times.

Heating water and domestic water must not come into contact with each other. Domestic water must not circulate through the exchanger.

Limit temperature at the draw-off point: the maximum domestic hot water temperature at the draw-off point is subject to special regulations in the various countries in which the appliance is sold in order to protect the user. These special regulations be observed when installing the appliance.

Take precautions with the domestic hot water. Depending on the heat pump settings, the domestic hot water temperature may exceed 65°C.

In order to limit the risk of being scalded, a thermostatic mixing valve must be installed on the domestic hot water flow pipes.

## 1.6 Hydraulic safety

---

When making the hydraulic connection, it is imperative that the standards and corresponding local directives be respected.

If radiators are connected directly to the heating circuit: install a differential valve between the indoor unit and the heating circuit.

Fit drainage valves between the indoor unit and the heating circuit.

Do not add any chemical products to the heating water without first consulting a water treatment specialist. For example: antifreeze, water softeners, products to increase or reduce the pH value, chemical additives and/or inhibitors. These may cause faults in the heat pump and damage the heat exchanger.

## 1.7 Recommendations for the installation

---

Install the heat pump's indoor unit in a frost-free location.

Insulate the pipes to reduce heat losses to a minimum.

Apply refrigerant oil to the flared parts to facilitate tightening and improve the seal.

Keep this document close to the place where the appliance is installed.

Do not make any modifications to the heat pump without the written consent of the manufacturer.

To benefit from extended warranty cover, no modifications should be made to the appliance.

Install the heat pump indoor unit and outdoor unit on a solid, stable structure able to bear its weight.

Do not install the heat pump in a place that has an atmosphere with a high salt content.

Do not install the heat pump in a place exposed to steam and combustion gases.

Do not install the heat pump in a place that may be covered in snow.

## 1.8 Specific instructions for service, maintenance and breakdowns

---

Maintenance work must be carried out by a qualified professional.

Only a qualified professional is authorised to set, correct or replace the safety devices.

Before any work, switch off the power supply to the heat pump, the indoor unit and the electrical back-up.

Wait for approx. 20-30 seconds for the outdoor unit capacitors to be discharged, and check that the lights on the outdoor unit PCBs have gone out.

Before working on the refrigeration circuit, switch off the appliance and wait a few minutes. Certain items of equipment such as the compressor and the pipes can reach temperatures in excess of 100°C and high pressures, which may cause serious injuries.

Locate and correct the cause of power cut before resetting the safety thermostat.

Only genuine spare parts may be used.



Removal and disposal of the heat pump must be carried out by a qualified professional in accordance with prevailing local and national regulations.

After maintenance or repair work, check the entire heating system to ensure that there are no leaks.

Remove the casing only to perform maintenance and repair work. Put the casing back in place after maintenance and repair work.

For heat pumps with a refrigerant fluid load of more than 5 tonnes of CO<sub>2</sub> equivalent, the user must have an annual leak-tightness test performed on the refrigerant equipment.

## 1.9 Liabilities

Tab.1

<p>Manufacturer's liability</p>	<p>Our products are manufactured in compliance with the requirements of the various Directives applicable. They are therefore delivered with the <b>CE</b> marking and any documents necessary. In the interests of the quality of our products, we strive constantly to improve them. We therefore reserve the right to modify the specifications given in this document.</p> <p>Our liability as manufacturer may not be invoked in the following cases:</p> <ul style="list-style-type: none"> <li>• Failure to abide by the instructions on installing the appliance.</li> <li>• Failure to abide by the instructions on using the appliance.</li> <li>• Faulty or insufficient maintenance of the appliance.</li> </ul>
<p>Installer's liability</p>	<p>The installer is responsible for the installation and initial commissioning of the appliance. The installer must observe the following instructions:</p> <ul style="list-style-type: none"> <li>• Read and follow the instructions given in the manuals provided with the appliance.</li> <li>• Install the appliance in compliance with prevailing legislation and standards.</li> <li>• Carry out initial commissioning and any checks necessary.</li> <li>• Explain the installation to the user.</li> <li>• If maintenance is necessary, warn the user of the obligation to check the appliance and keep it in good working order.</li> <li>• Give all the instruction manuals to the user.</li> </ul>

## 2 Symbols used

### 2.1 Symbols used in the manual

This manual uses various danger levels to draw attention to special instructions. We do this to improve user safety, to prevent problems and to guarantee correct operation of the appliance.

 **Danger**  
Risk of dangerous situations that may result in serious personal injury.

 **Danger of electric shock**  
Risk of electric shock.

 **Warning**  
Risk of dangerous situations that may result in minor personal injury.

 **Caution**  
Risk of material damage.

 **Important**  
Please note: important information.

 **See**  
Reference to other manuals or pages in this manual.

### 2.2 Symbols used on the appliance

Fig.1



Caution: danger of electric shock

- 1 Disconnect the mains power prior to carrying out any work.
- 2 Work on the appliance is only authorised if carried out by a qualified engineer

Fig.2

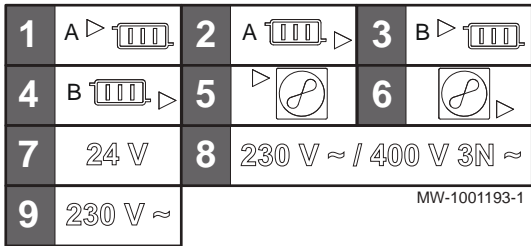

- 1 CIRCA0 heating circuit flow
- 2 CIRCA0 heating circuit return
- 3 CIRCB1 heating circuit flow
- 4 CIRCB1 heating circuit return
- 5 Refrigeration fluid connection - liquid line
- 6 Refrigeration fluid connection - gas line
- 7 Safety extra-low voltage power supply cable
- 8 Power supply cable 230 V / 400 V
- 9 Power cord 230 V

### 2.3 Symbols used on the data plate

Fig.3

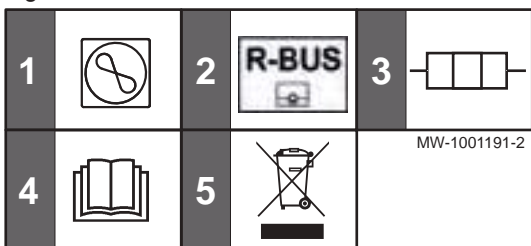

- 1 Information concerning the heat pump: refrigerant type, maximum allowable operating pressure
- 2 The symbol indicates compatibility with the Baxi uSense connected thermostat.
- 3 Information on the electrical back-up: power supply and maximum output
- 4 Before installing and commissioning the appliance, carefully read the instruction manuals provided
- 5 Dispose of used products in an appropriate recovery and recycling structure

## 3 Technical specifications

### 3.1 Homologations

#### 3.1.1 Directives

This product complies with the requirements of the following European Directives and Standards:

- Pressure Equipment Directive 2014/68/EU
- Low Voltage Directive 2014/35/EU  
Generic standard: EN 60335-1  
Relevant standards: EN 60335-2-40, EN 60335-2-21
- Electromagnetic Compatibility Directive 2014/30/EU  
Generic standards: EN 61000-6-3, EN 61000-6-1  
Relevant Standard: EN 55014

This product complies with the requirements of European Directive 2009/125/EC on the ecodesign of energy-related products.

This product complies with the MCS and HARP certifications.

In addition to the legal requirements and guidelines, the supplementary guidelines in this manual must also be followed.

Supplements or subsequent regulations and guidelines that are valid at the time of installation shall apply to all regulations and guidelines specified in this manual.

#### 3.1.2 EC Declaration of Conformity

The unit complies with the standard type described in the EC declaration of conformity. It has been manufactured and put into circulation in accordance with the requirements of the European Directives.

The original declaration of conformity is available from the manufacturer.

#### 3.1.3 Factory test

Before leaving the factory, each indoor unit is tested on the following points:

- Tightness of the heating circuit
- Electrical safety
- Tightness of the refrigerant circuit

### 3.2 Technical data

#### 3.2.1 Compatible heating devices

Tab.2

Outdoor unit	Associated/compatible indoor units
AWHP 4.5 MR	Assure AWHP-IDU 4-8 E
AWHP 6 MR-3	Assure AWHP-IDU 4-8 E
AWHP 8 MR-2	Assure AWHP-IDU 4-8 E

#### 3.2.2 Heat pump

The specifications are valid for a new appliance with clean heat exchangers.

Maximum operating pressure: 0.3 MPa (3 bar)

Tab.3 Outdoor unit conditions of use

Limit operating temperatures	AWHP 4.5 MR	AWHP 6 MR-3	AWHP 8 MR-2
Water in heating mode	+18 °C/+55 °C	+18 °C/+60 °C	+18 °C/+60 °C
Outdoor air in heating mode	-15 °C/+35 °C	-15 °C/+35 °C	-20 °C/+35 °C

Tab.4 Heating mode: outside air temperature +7 °C, water temperature at the outlet +35 °C. Performances in accordance with EN 14511-2.

Measurement type	Unit	AWHP 4.5 MR	AWHP 6 MR-3	AWHP 8 MR-2
Heat output	kW	4.60	5.87	8.26
Coefficient of Performance (COP)		5.11	4.18	4.27
Absorbed electrical power	kWe	0.90	1.41	1.93
Nominal water flow rate ( $\Delta T = 5$ K)	m <sup>3</sup> /hour	0.80	1.04	1.47

Tab.5 Heating mode: outside air temperature +2 °C, water temperature at the outlet +35 °C. Performances in accordance with EN 14511-2.

Measurement type	Unit	AWHP 4.5 MR	AWHP 6 MR-3	AWHP 8 MR-2
Heat output	kW	3.47	3.74	5.93
Coefficient of Performance (COP)		3.97	3.30	3.12
Absorbed electrical power	kWe	0.88	1.11	1.90

Tab.6 Common specifications

Measurement type	Unit	AWHP 4.5 MR	AWHP 6 MR-3	AWHP 8 MR-2
Total dynamic head at nominal flow rate	kPa	62	61.80	49.30
Nominal air flow rate	m <sup>3</sup> /h	2680	2700	3000
Power voltage of the outdoor unit	V	230	230	230
Start-up amperage	A	5	5	5
Maximal amperage	A	12	13	17
Acoustic power - Inside <sup>(1)</sup>	dB(A)	43	43	51
Acoustic power - Outside <sup>(2)</sup>	dB(A)	58	65	65
Refrigerant fluid R410A	kg	1.4	1.3	3.2
R410A refrigerant <sup>(3)</sup>	tCO <sub>2</sub> e	2.922	2.714	6.680
Refrigerant connection (Liquid - Gas)	inch	1/4 - 1/2	1/4 - 1/2	3/8 - 5/8
Max. pre-charged length	m	7	10	10

(1) Noise radiated by the envelope - Test run in accordance with the NF EN 12102 standard, temperature conditions: air 7 °C, water 55 °C  
(2) Noise radiated by the envelope - Test run in accordance with the NF EN 12102 standard, temperature conditions: air 7 °C, water 45 °C for AWHP 4.5 MR only (inner and outer sides).  
(3) Quantity of refrigerant calculated in tonnes of CO<sub>2</sub> equivalent

**Important**

The quantity of refrigerant fluid in tonnes of CO<sub>2</sub> equivalent is calculated using the following formula: quantity (in kg) of refrigerant fluid x GWP / 1000. The Global Warming Potential (GWP) of R410A is 2088.

**3.2.3 Heat pump weight**

Tab.7 Indoor module

Indoor module	Unit	Assure AWHP-IDU 4-8 E
Net weight	kg	59
Gross weight	kg	70

Tab.8 Outdoor unit

Outdoor unit	Unit	AWHP 4.5 MR	AWHP 6 MR-3	AWHP 8 MR-2
Weight	kg	54	42	75

### 3.2.4 Combination heaters with medium-temperature heat pump

Tab.9 Technical parameters for heat pump combination heaters (parameters declared for medium-temperature application)

Product name			AWHP 4.5 MR	AWHP 6 MR-3	AWHP 8 MR-2
Air-to-water heat pump			Yes	Yes	Yes
Water-to-water heat pump			No	No	No
Brine-to-water heat pump			No	No	No
Low-temperature heat pump			No	No	No
Equipped with a supplementary heater			Yes	Yes	Yes
Heat pump combination heater			No	No	No
<b>Rated heat output under average conditions<sup>(1)</sup></b>	<i>Prated</i>	kW	3	4	6
<b>Rated heat output under colder conditions</b>	<i>Prated</i>	kW	5	4	6
<b>Rated heat output under warmer conditions</b>	<i>Prated</i>	kW	4	5	6
<b>Declared capacity for heating for part load at an indoor temperature of 20 °C and outdoor temperature <math>T_j</math></b>					
$T_j = -7$ °C	<i>Pdh</i>	kW	3.8	3.4	5.6
$T_j = +2$ °C	<i>Pdh</i>	kW	4.3	2.2	2.9
$T_j = +7$ °C	<i>Pdh</i>	kW	4.5	2.1	6.4
$T_j = +12$ °C	<i>Pdh</i>	kW	5.5	2.6	4.3
$T_j =$ bivalent temperature	<i>Pdh</i>	kW	3.1	3.9	5.6
$T_j =$ operation limit temperature	<i>Pdh</i>	kW	3.1	3.9	5.6
Bivalent temperature	$T_{biv}$	°C	-10	-10	-10
Degradation coefficient <sup>(2)</sup>	<i>Cdh</i>	—	1.0	1.0	1.0
<b>Seasonal space heating energy efficiency under average conditions</b>	$\eta_s$	%	134	125	129
<b>Seasonal space heating energy efficiency under colder conditions</b>	$\eta_s$	%	109	116	119
<b>Seasonal space heating energy efficiency under warmer conditions</b>	$\eta_s$	%	179	172	169
<b>Declared coefficient of performance or primary energy ratio for part load at an indoor temperature of 20 °C and outdoor temperature <math>T_j</math></b>					
$T_j = -7$ °C	<i>COPd</i>	-	1.64	1.75	1.95
$T_j = +2$ °C	<i>COPd</i>	-	3.46	3.18	3.22
$T_j = +7$ °C	<i>COPd</i>	-	4.96	4.56	4.57
$T_j = +12$ °C	<i>COPd</i>	-	7.90	6.41	6.55
$T_j =$ bivalent temperature	<i>COPd</i>	-	1.20	1.56	1.70
$T_j =$ operation limit temperature	<i>COPd</i>	-	1.20	1.56	1.70
Operation limit temperature for air-to-water heat pumps	<i>TOL</i>	°C	-10	-10	-10
Heating water operating limit temperature	<i>WTOL</i>	°C	55	60	60
<b>Electrical power consumption</b>					
Off mode	$P_{OFF}$	kW	0.009	0.009	0.009
Thermostat-off mode	$P_{TO}$	kW	0.049	0.049	0.049
Stand-by	$P_{SB}$	kW	0.012	0.016	0.018
Crankcase heater mode	$P_{CK}$	kW	0.000	0.055	0.055

Product name			AWHP 4.5 MR	AWHP 6 MR-3	AWHP 8 MR-2
<b>Supplementary heater</b>					
Rated heat output	$P_{sup}$	kW	0.0	0.0	0.0
Type of energy input			Electricity	Electricity	Electricity
<b>Other specifications</b>					
Capacity control			Variable	Variable	Variable
Sound power level, indoors - outdoors	$L_{WA}$	dB	43 - 58	43 - 65	51 - 65
Annual energy consumption under average conditions	$Q_{HE}$	kWh	2353	2124	3499
Annual energy consumption under colder conditions	$Q_{HE}$	kWh	4483	3721	4621
Annual energy consumption under warmer conditions	$Q_{HE}$	kWh	1249	1492	1904
Rated air flow rate, outdoors for air-to-water heat pumps	—	m <sup>3</sup> /h	2680	2700	3300
(1) The rated heat output $P_{rated}$ is equal to the design load for heating $P_{design,h}$ , and the rated heat output of a supplementary heater $P_{sup}$ is equal to the supplementary capacity for heating $sup(T_j)$ . (2) If $C_{dh}$ is not determined by measurement, the default degradation coefficient is $C_{dh} = 0.9$ .					



**See**

The back cover for contact details.

### 3.2.5 Sensor specifications

#### ■ Outdoor temperature sensor specifications

Tab.10 AF60 outdoor temperature sensor

Temperature	°C	-20	-16	-12	-8	-4	0	4	8	12	16	20	24	30	35
Resistance	Ohm	2392	2088	1811	1562	1342	1149	984	842	720	616	528	454	362	301

#### ■ Heating flow sensor specifications

Tab.11 NTC heating flow sensor

Temperature	°C	0	10	20	25	30	40	50	60	70	80	90
Resistance	Ohm	32014	19691	12474	10000	8080	5372	3661	2535	1794	1290	941

#### ■ Specifications of the heat pump flow and return temperature sensors

Tab.12 PT1000 temperature sensor

Temperature	°C	-10	0	10	20	30	40	50	60	70	80	90	100
Resistance	Ohm	961	1000	1039	1077	1117	1155	1194	1232	1271	1309	1347	1385

### 3.2.6 Circulating pumps



**Important**

The benchmark for the most efficient circulating pumps is  $E_{EE} \leq 0.20$ .

The exchanger circulating pump (sometimes called the "heat pump circulating pump") does not need any adjustment. It is automatically configured with the codes CN1 and CN2 when the appliance is commissioned. The heating circulating pump must be configured using the speed settings button, according to the heating circuit specifications.

Fig.4 Variable pressure

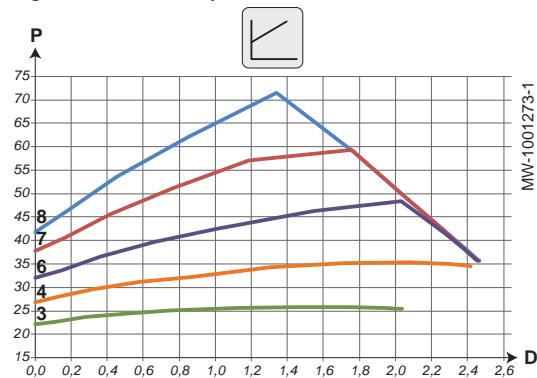

- P Available pressure (kPa)
- D Water flow rate in cubic metres per hour (m<sup>3</sup>/h)
- 3 Speed 3
- 4 Speed 4
- 6 Speed 6
- 7 Speed 7
- 8 Speed 8

Fig.5 Constant pressure

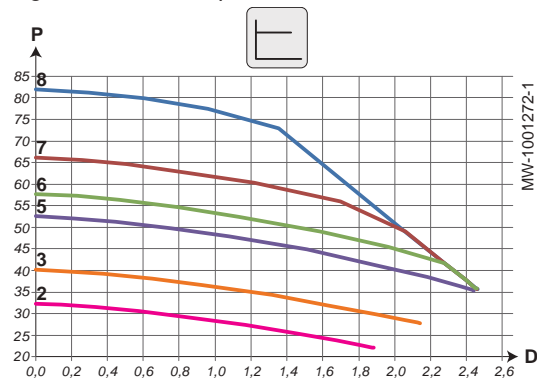

- P Available pressure (kPa)
- D Water flow rate in cubic metres per hour (m<sup>3</sup>/h)
- 2 Speed 2
- 3 Speed 3
- 5 Speed 5
- 6 Speed 6
- 7 Speed 7
- 8 Speed 8

### 3.3 Dimensions and connections

#### 3.3.1 Indoor unit

Fig.6

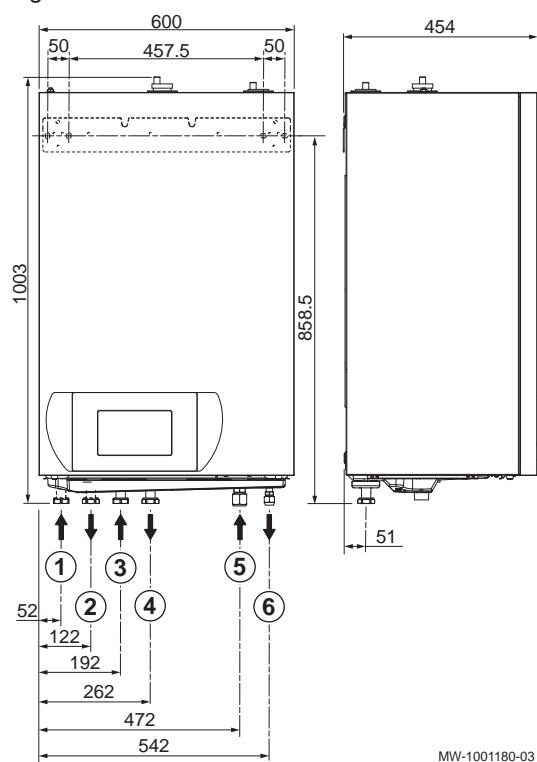

- 1 Three-way valve circuit return (optional) - G1"
- 2 Three-way valve circuit flow (optional) - G1"
- 3 Direct circuit return - G1"
- 4 Direct circuit flow - G1"
- 5 Refrigerant connection - gas line
  - 5/8" for 4.5 to 16 kW models
- 6 Refrigerant connection - liquid line
  - 3/8" for 4.5 to 16 kW models

**3.3.2 AWHP 4.5 MR outdoor unit**

Fig.7

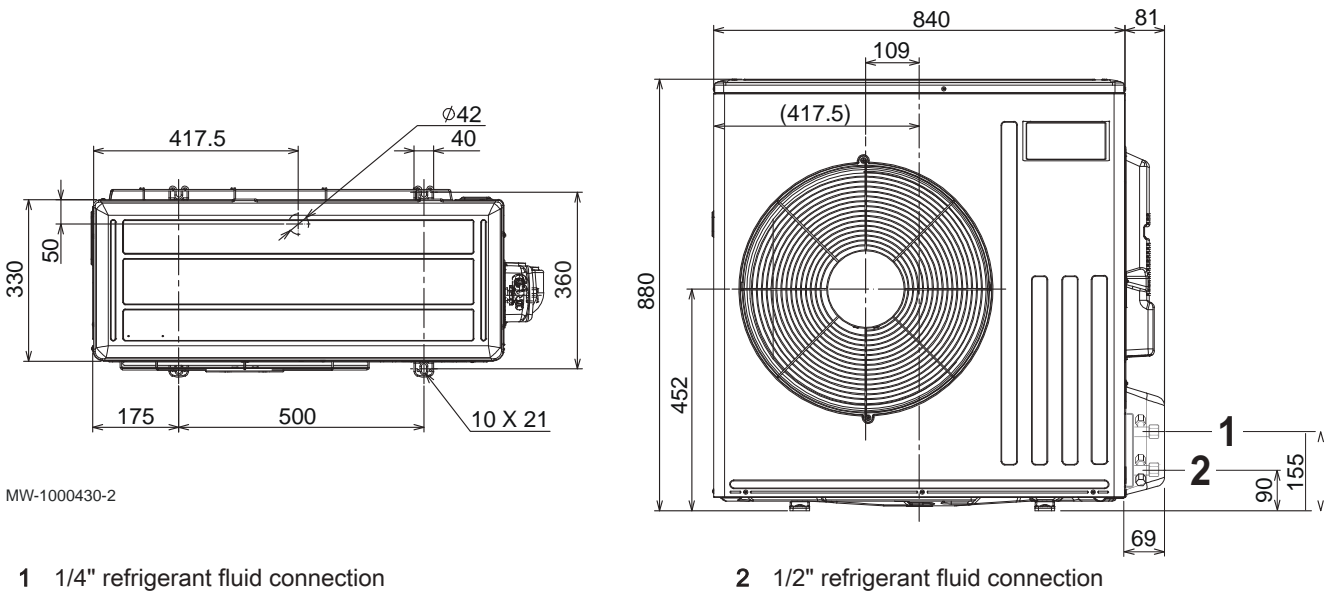

**3.3.3 AWHP 6 MR-3 outdoor unit**

Fig.8

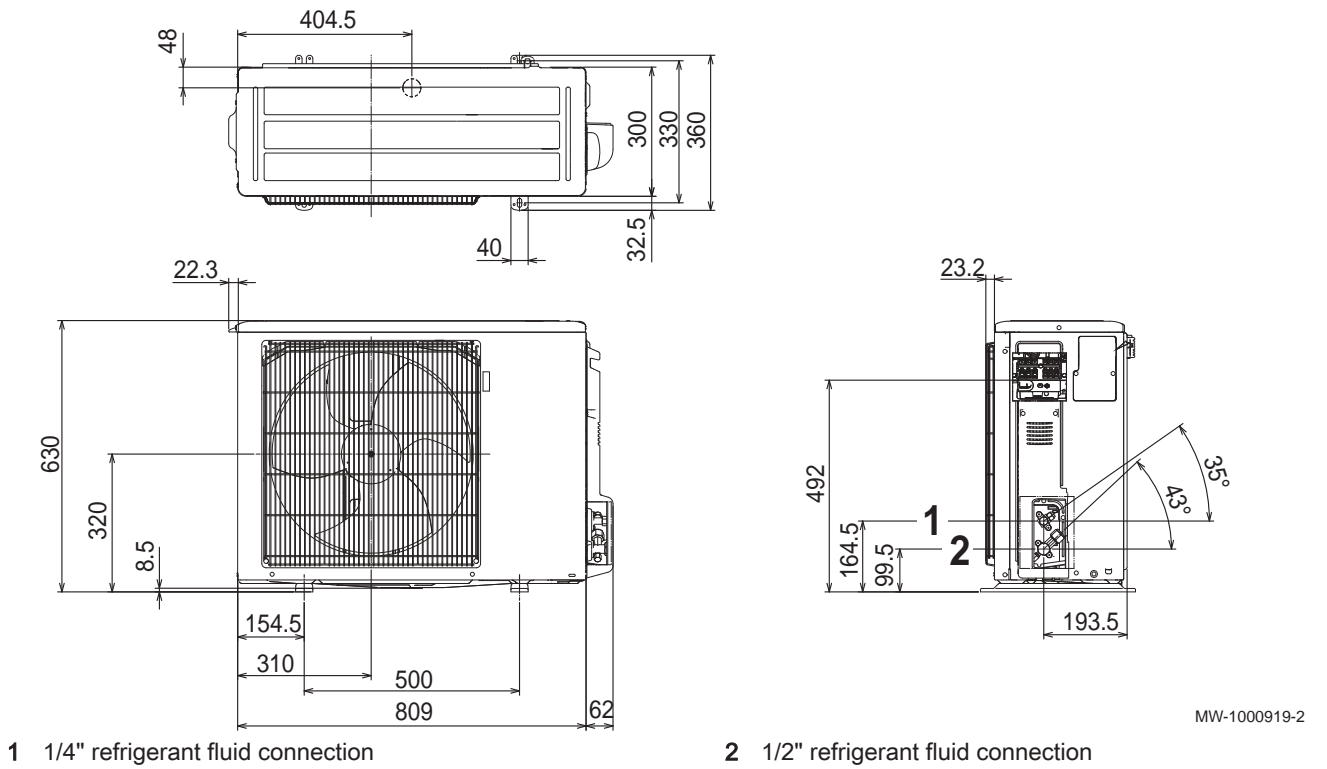



3.3.4 AWHP 8 MR-2 outdoor unit

Fig.9

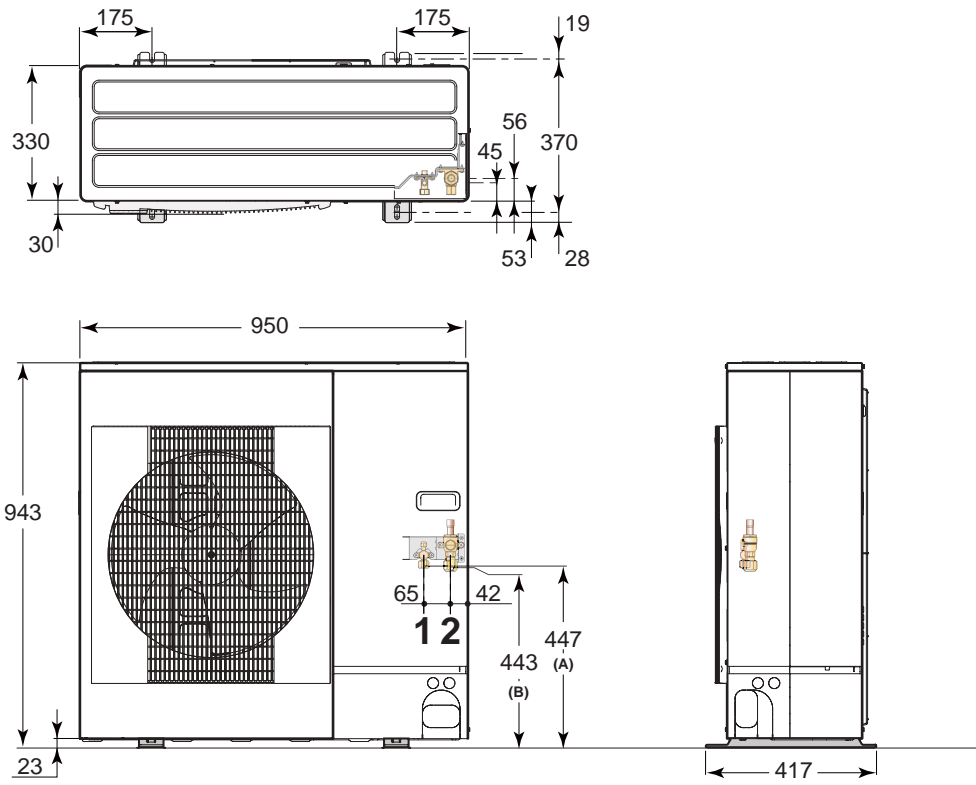

MW-M001442-4

1 3/8" refrigerant fluid connection

2 5/8" refrigerant fluid connection

### 3.4 Electrical diagram

Fig.10

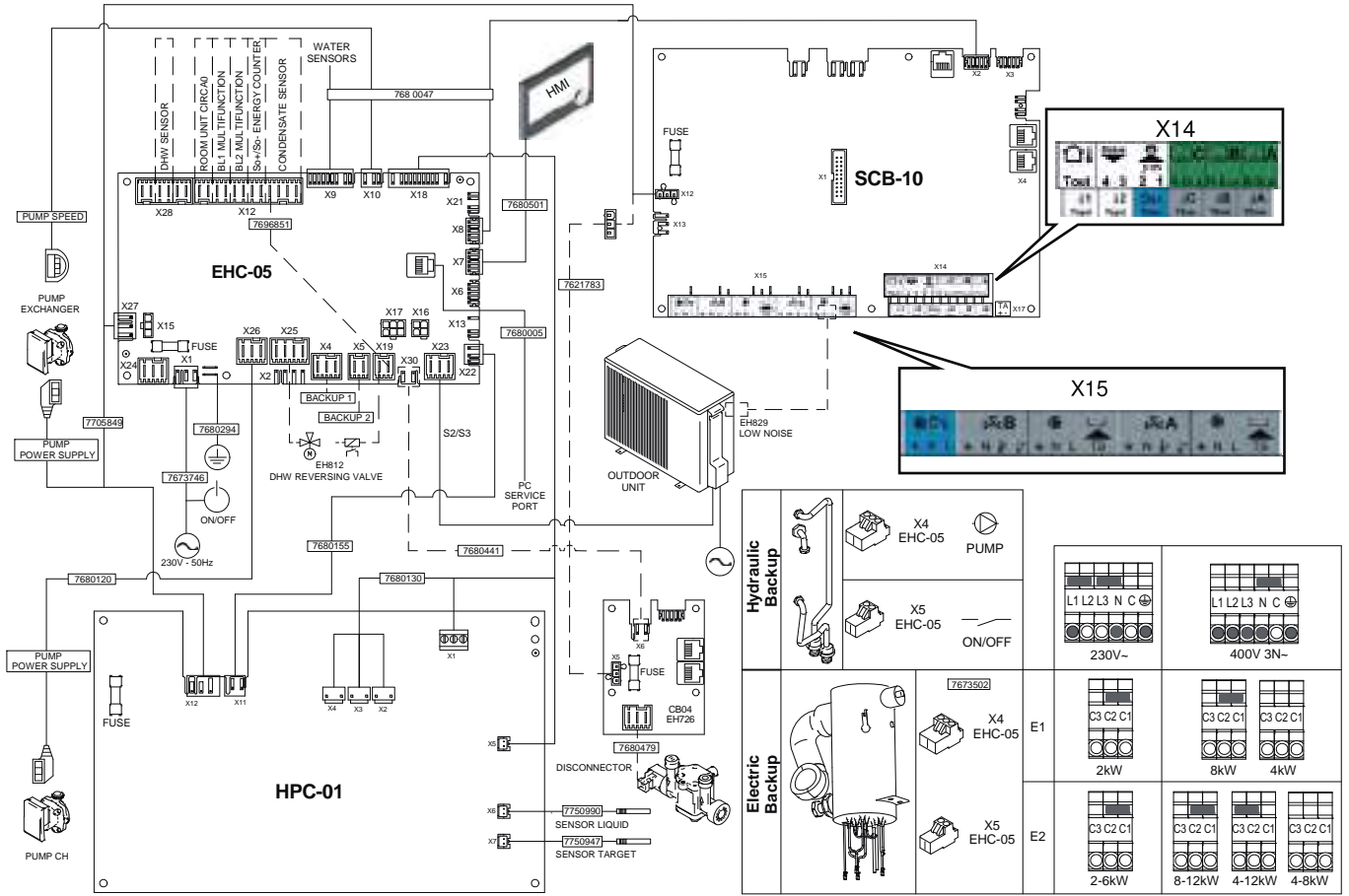

MW-1001139-3

Tab.13 Electrical diagram legend

230V~	Power supply
BACKUP 1	<ul style="list-style-type: none"> <li>Hydraulic version: Hydraulic back-up pump</li> <li>Electrical version: Electrical back-up - stage 1</li> </ul>
BACKUP 2	<ul style="list-style-type: none"> <li>Hydraulic version: Hydraulic back-up ON/OFF contact</li> <li>Electrical version: Electrical back-up - stage 2</li> </ul>
BL1 MULTIFUNCTION	BL1 multifunction input
BL2 MULTIFUNCTION	BL2 multifunction input
CB04	Automatic filling kit
CONDENSATE SENSOR	Condensation sensor for underfloor heating
DHW REVERSING VALVE	Domestic hot water tank three-way valve
DHW SENSOR	Domestic hot water tank sensor
EHC-05	Heat pump control system central unit PCB
DISCONNECTOR	Disconnecter
ELECTRICAL BACKUP	Electrical back-up
FUSE	Fuse
HPC-01	PCB: interface for the outdoor unit
HYDRAULIC BACKUP	Hydraulic back-up
OUTDOOR UNIT	Outdoor unit
OUTSIDE TEMPERATURE SENSOR	Outdoor temperature sensor
PC SERVICE PORT	Service Tool connector
PUMP CH	Heating circulating pump
PUMP EXCHANGER	Heat pump circulating pump
ROOM UNIT CIRCA0	Baxi uSense connected room thermostat, on/off thermostat, modulating thermostat or OpenTherm thermostat for the CIRCA0 direct zone

SCB-10	PCB for controlling the additional heating and domestic hot water circuits
SENSOR LIQUID	Exchanger refrigerant temperature sensor
SENSOR TARGET	Water temperature sensor on the exchanger outlet
SO+/SO- ENERGY COUNTER	SO+/SO- energy meter
WATER SENSORS	Temperature sensors

## 4 Description of the product

### 4.1 Operating principle

The outdoor unit produces heat and transfers it to the indoor module via the refrigerant in the plate exchanger.

The indoor module is equipped with a specific control system which is used to adjust the temperature of the heating water to the needs of the home.

### 4.2 Main components

Fig.11

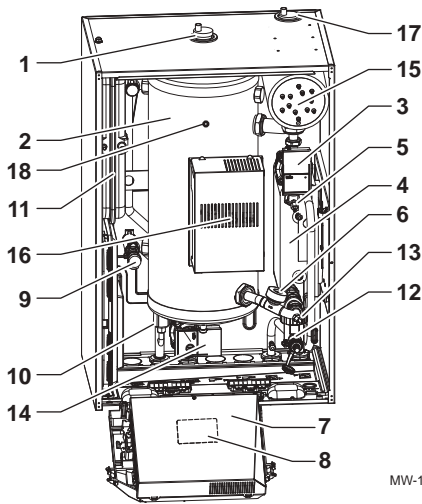

MW-1001189-3

#### With electrical back-up

- 1 Automatic air vent
- 2 Low-loss header (40l)
- 3 Heat pump circulating pump
- 4 Plate heat exchanger
- 5 Heat pump flow temperature sensor (PT1000)
- 6 Flow meter
- 7 Switching control panel unit
- 8 Electrical diagram
- 9 Safety valve
- 10 Electronic pressure gauge
- 11 Expansion vessel
- 12 Magnetic filter
- 13 Heat pump return temperature sensor (PT1000)
- 14 Heating circulating pump
- 15 Electric preheater
- 16 PCB for controlling the electric preheater
- 17 Automatic air vent
- 18 Heating flow temperature sensor

Fig.12

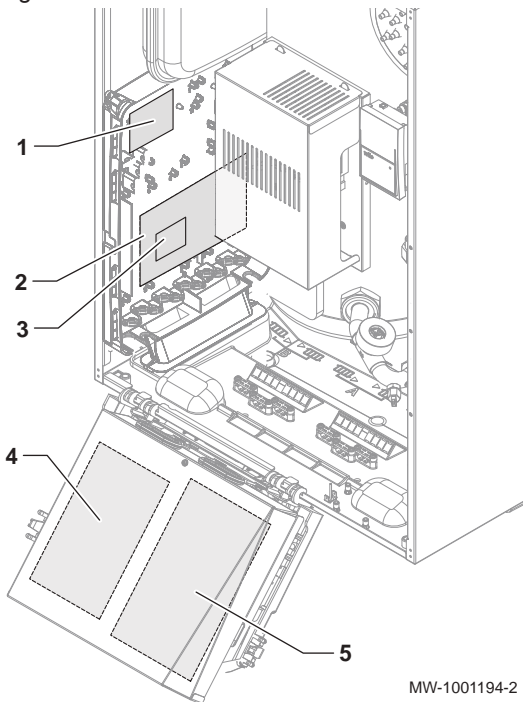

MW-1001194-2

#### Position of the PCBs

Marker	PCB	Function
1	CB04 optional PCB	Filling kit
2	SCB-10 PCB	Additional heating and domestic hot water circuits
3	AD249 PCB (option)	Management of heating circuit C1 and auxiliary circuit AUX1
4	EHC-05 central unit PCB	Control system for the heat pump, first heating circuit and domestic hot water
5	HPC-01 PCB	Interface PCB for the outdoor unit

### 4.3 Standard delivery

---

Tab.14

Package	Contents
Outdoor unit	<ul style="list-style-type: none"><li>• An outdoor unit</li><li>• A manual</li></ul>
Indoor unit	<ul style="list-style-type: none"><li>• An indoor unit</li><li>• An accessories bag containing:<ul style="list-style-type: none"><li>- One outdoor temperature sensor</li><li>- One mechanical pressure gauge with a T fitting</li><li>- One domestic hot water sensor</li></ul></li><li>• An installation and service manual</li><li>• A user guide</li><li>• Package EH146</li></ul>

## 5 Connecting diagrams and configuration

### 5.1 Installation with electrical back-up, two circuits and a domestic hot water tank

Fig.13 Connect CIRC A0 to EHC-05 and CIRC B1 to SCB-10

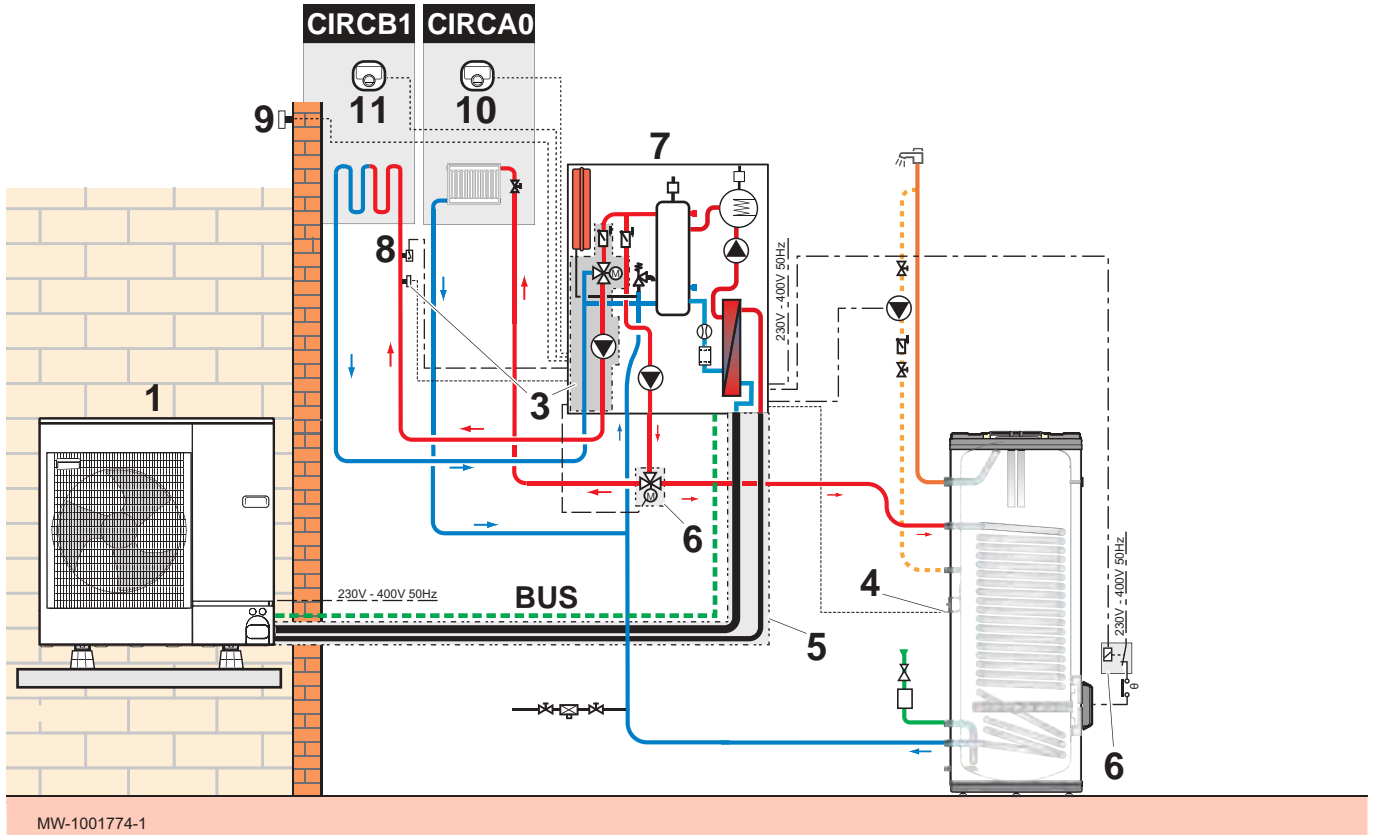

MW-1001774-1

- |  |                                       |
|--|---------------------------------------|
| 1 Outdoor unit                               | 7 Indoor unit                         |
| 3 Three-way internal valve kit               | 8 Safety thermostat                   |
| 4 Domestic hot water sensor                  | 9 Outdoor temperature sensor          |
| 5 Refrigerant connection 5/8" – 3/8", 5 m    | 10 Thermostat connected to circuit A  |
| 6 Heating/domestic hot water reversing valve | 11 Connected thermostat for circuit B |

#### 5.1.1 Make the electrical connections

1. Connect the accessories and options to the **EHC-05** PCB, respecting the 230-400 V and 0-40 V cable feed-throughs.
2. Connect the accessories and options to the **SCB-10** PCB, respecting the 230-400 V and 0-40 V cable feed-throughs.
  - ⇒ The icons corresponding to the B1 and domestic hot water circuit appear on the user interface. The A0 circuit icon is present as default.

Fig.14 Connect CIRC A0 to EHC-05 and CIRC B1 to SCB-10

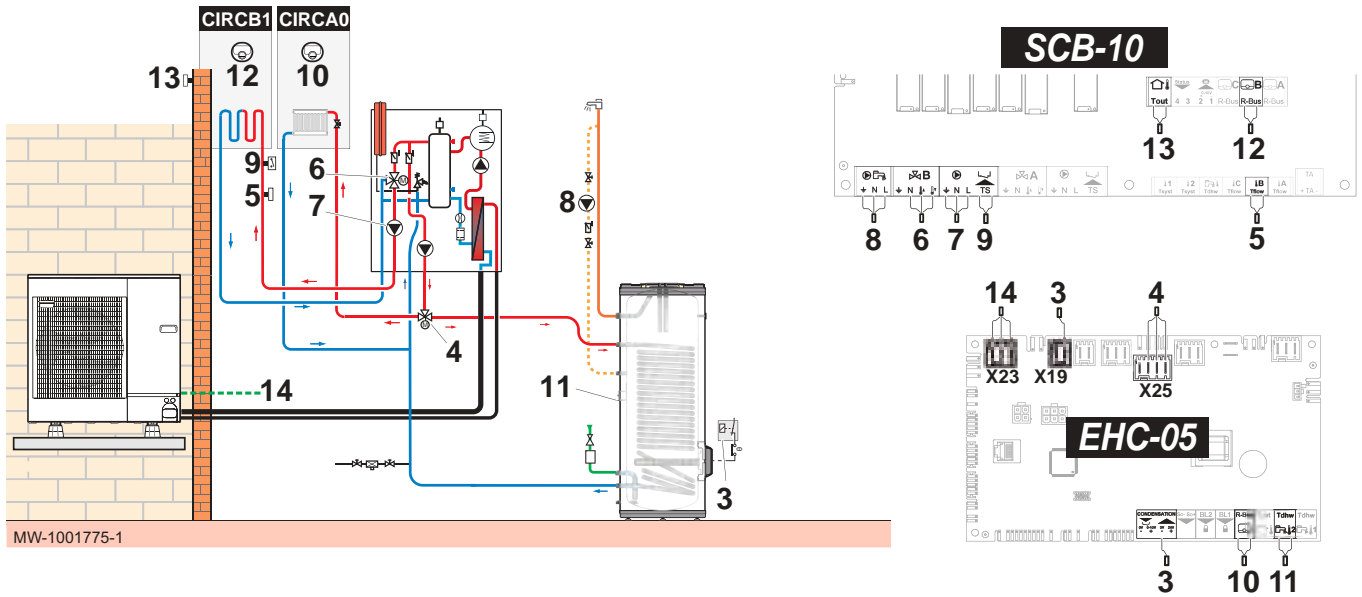

- 3 X19: Control signal for the immersion heater, used to control the immersion heater on the reversal valve kit

4 X25: Reversal valve from the reversal valve kit: A0/ domestic hot water circuit

5 Flow sensor – B1 circuit

6 Three-way valve – B1 circuit

7 Power supply for the B1 circuit pump
- 8 Domestic hot water recirculating pump

9 Safety thermostat for underfloor heating flow

10 X12 R-Bus: Thermostat connected to A0 circuit

11 X28 Tdhw2: domestic hot water sensor

12 Thermostat connected to B1 circuit

13 Outdoor temperature sensor

14 X23: Outdoor unit bus connection

### 5.1.2 Applying the parameters

1. To configure the back-up boiler: on first start-up or after resetting the factory settings, set the CN1 and CN2 parameters according to the information on the data plate and the outdoor unit output.
2. Configure and check the parameters of the A0 circuit.



Tab.15

Access	Parameter	Adjustment required
<p>21.7 CIRCA0 &gt; Parameters, counters, signals &gt; Parameters</p>	MaxZoneTFlowSetpoint (CP000)	Maximum Flow Temperature setpoint zone: 75 °C Adjust the temperature as required
	Zone Function (CP020)	Functionality of the zone: Direct

3. Set the heating curve on the A0 circuit to a gradient of 1.5. Adapt the values of the heating curve in order to obtain optimum comfort.
4. Configure the parameters for the B1 circuit.



Tab.16

Access	Parameter	Adjustment required
<p>19.8 CIRC B1 &gt; Parameters, counters, signals &gt; Parameters</p>	MaxZoneTFlowSetpoint (CP000)	Maximum Flow Temperature setpoint zone: 40 °C Adjust the temperature according to need
	Zone Function (CP020)	Functionality of the zone: Mixing Circuit

5. Set the heating curve on the B1 circuit with a gradient between 0.4 and 0.7. Adapt the values of the heating curve in order to obtain optimum comfort.



6. Configure the parameters of the (DHW) domestic hot water tank.

Tab.17

Access	Parameter	Adjustment required
DHW tank > Parameters, counters, signals > Parameters	Max. DHW duration (DP047) Maximum duration of the DHW production	3 hours Adjust the duration according to need
	Min. CH before DHW(DP048) Min. heating duration before DHW prod.	2 hours Adjust the duration according to need
	DHW management (DP051)	ECO (Only HP)
	Hysteresis DHW temperature setpoint (DP120)	15 °C Adjust the temperature as required



7. Configure the heat pump parameters

Tab.18

Access	Parameter	Adjustment required
Air Src Heat pump > Parameters, counters, signals > Adv. Parameters	Cooling mode (AP028)	Configuration of the cooling mode <ul style="list-style-type: none"> <li>• Off</li> <li>• Active cooling on</li> </ul>

⇒ • Authorisation for cooling has been set.



8. Configure the parameters for the immersion heater on the domestic hot water tank.

Tab.19

Access	Parameter	Adjustment required
DHW tank > Parameters, counters, signals > Adv. Parameters	DHW backup type (DP334)	IDU/DhwTank Cooling
Air Src Heat pump > Parameters, counters, signals > Adv. Parameters	kW rating DHW backup(HP145)	2.4 kW

9. Configure the timer programme for the domestic hot water 1 (DHW1) to configure the operating hours of the recirculating pump. See the user guide.

10. Configure the timer programme for the A0, B1 and domestic hot water circuits.



**For more information, see**

Data Plates, page 26

Configuration numbers CN1 et CN2, page 54

## 5.2 Connecting a swimming pool

To control swimming pool heating, you will need the optional **AD249** printed circuit board and a swimming pool thermostat. A low-loss header will also be required to ensure the heat pump operates correctly with a swimming pool.

The swimming pool is not heated when the contact is open (factory setting). Only the frost protection continues to run.

- The thermostat contact is open when the swimming pool temperature is higher than the thermostat set point.
- When the contact is closed, the swimming pool is heated.



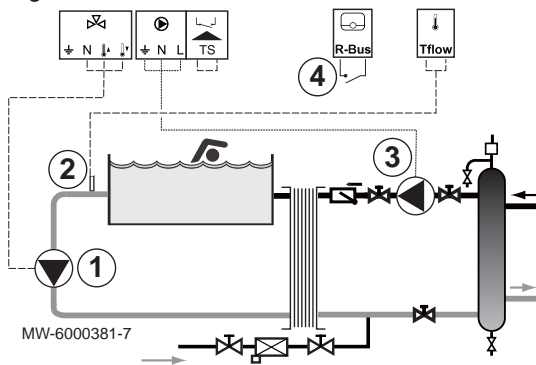

Fig.15



The electrical connection of a swimming pool is made to the optional AD249 PCB.

1. Connect the swimming pool's secondary pump to terminal block  of the selected circuit (**CIRCA1**, **CIRCB1** or **CIRCC1**).

Three-way valve terminal block	Connecting the pump
Earthing connector	Earth wire
N connector	Pump neutral
Opening control connector 	Power supply for pump

2. Connect the swimming pool temperature sensor to the TFlow terminal block.
3. Connect the swimming pool's primary pump to terminal block  of the selected circuit (**CIRCA1**, **CIRCB1** or **CIRCC1**).
4. Connect the swimming pool heating cut-off control to the R-Bus terminal block.

## 6 Installation

### 6.1 Installation regulations



#### Warning

The components used for the connection to the cold water supply must comply with the prevailing standards and regulations in the country concerned.

Pursuant to European Regulation 517/2014, the equipment must be installed by a certified operator whenever the refrigerant load is in excess of 5 tonnes of CO<sub>2</sub> equivalent or when a refrigerant connection is necessary (the case with split systems, even when fitted with a quick coupling device).



#### Caution

Installation of the heat pump must be done by a qualified professional in accordance with prevailing local and national regulations.

### 6.2 Data Plates

Fig.16

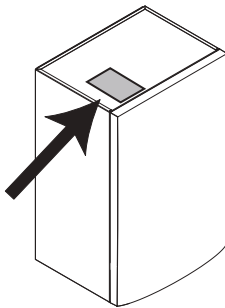

MW-1001195-1

#### 6.2.1 Data plate on the indoor module

The data plates identify the product and provide the following important information.

The data plates must be accessible at all times.



#### Important

Never remove or cover labels and data plates affixed to the appliances. Labels and data plates must be legible throughout the entire lifetime of the appliance.

Damaged or illegible instructions and warning stickers must be replaced immediately.

#### 6.2.2 Data plate on the outdoor unit

Fig.17

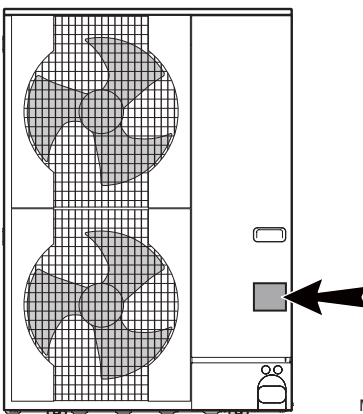

MW-M001832-1

### 6.3 Respecting the distance between the indoor module and the outdoor unit

To ensure that the heat pump functions correctly, respect the minimum and maximum connection lengths between the indoor module and the outdoor unit.

Fig.18

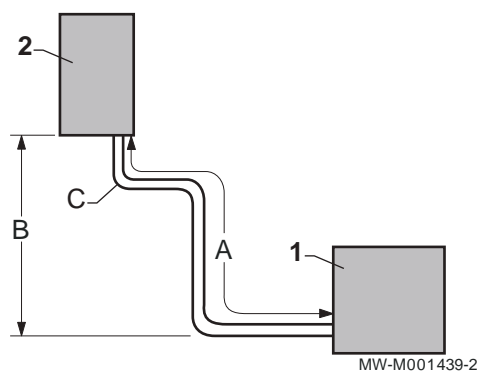

1. Respect distances A, B and C between the outdoor unit 1 and the indoor module 2.

Tab.20

	A: Maximum/ minimum length	B: Maximum height differ- ence	C: Maximum number of el- bows
AWHP 4.5 MR	2 to 30 m	30 m	10
AWHP 6 MR-3	2 to 40 m	30 m	15
AWHP 8 MR-2	2 to 40 m	30 m	15

2. Make one or two horizontal loops with the refrigerant connections to reduce disruption.  
If the length of the refrigerant connections is less than 2 m, disruptions can occur:
  - Functional disruptions caused by a fluid overload,
  - Noise pollution caused by the circulation of the refrigerant.

## 6.4 Positioning the indoor unit

### 6.4.1 Allowing sufficient space for the indoor module

Fig.19

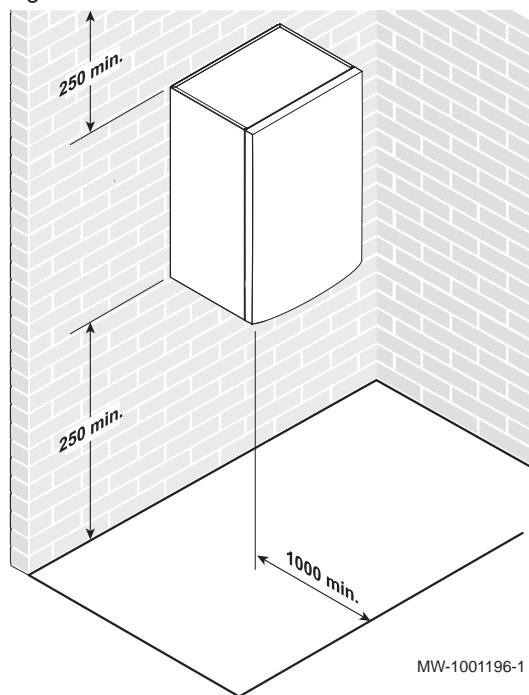

Allow sufficient space around the heat pump indoor module to ensure adequate access and facilitate maintenance.

Fig.20

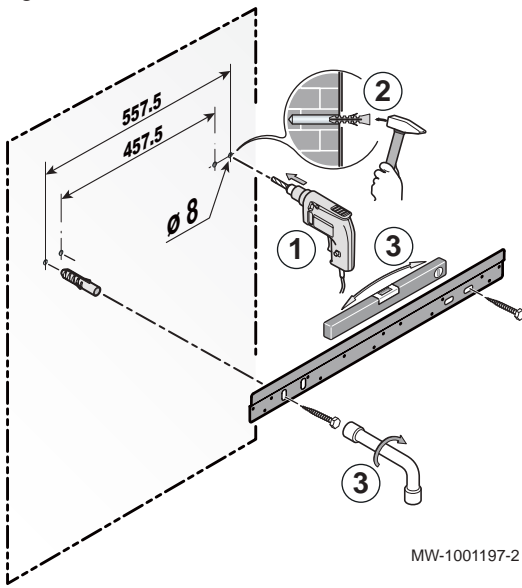

### 6.4.2 Fitting the assembly rail

1. Drill 2 holes with a diameter of 8 mm.

**i Important**  
Extra holes are provided in case one or other of the standard locating holes prevents the correct location of the plug.

**i Important**  
Check that the wall is able to bear the weight of the indoor unit.

2. Put the plugs in place.
3. Fix the mounting rail to the wall using the hexagonal head screws provided for this purpose. Set the level using a spirit level.

Fig.21

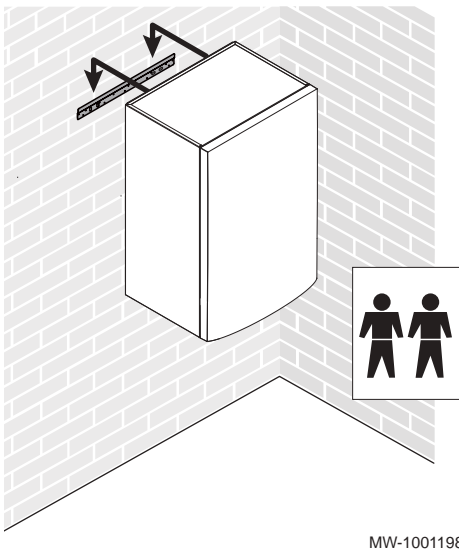

### 6.4.3 Mounting the unit on the wall

1. Position the indoor unit above the mounting rail so that it rests snugly against it.

**i Important**  
If necessary, use suitable lifting equipment.

2. Gently lower the indoor unit.

## 6.5 Putting the outdoor unit in place

### 6.5.1 Allowing sufficient space for the outdoor unit

Minimum distances from the wall are necessary in order to guarantee optimum performance.

Fig.22

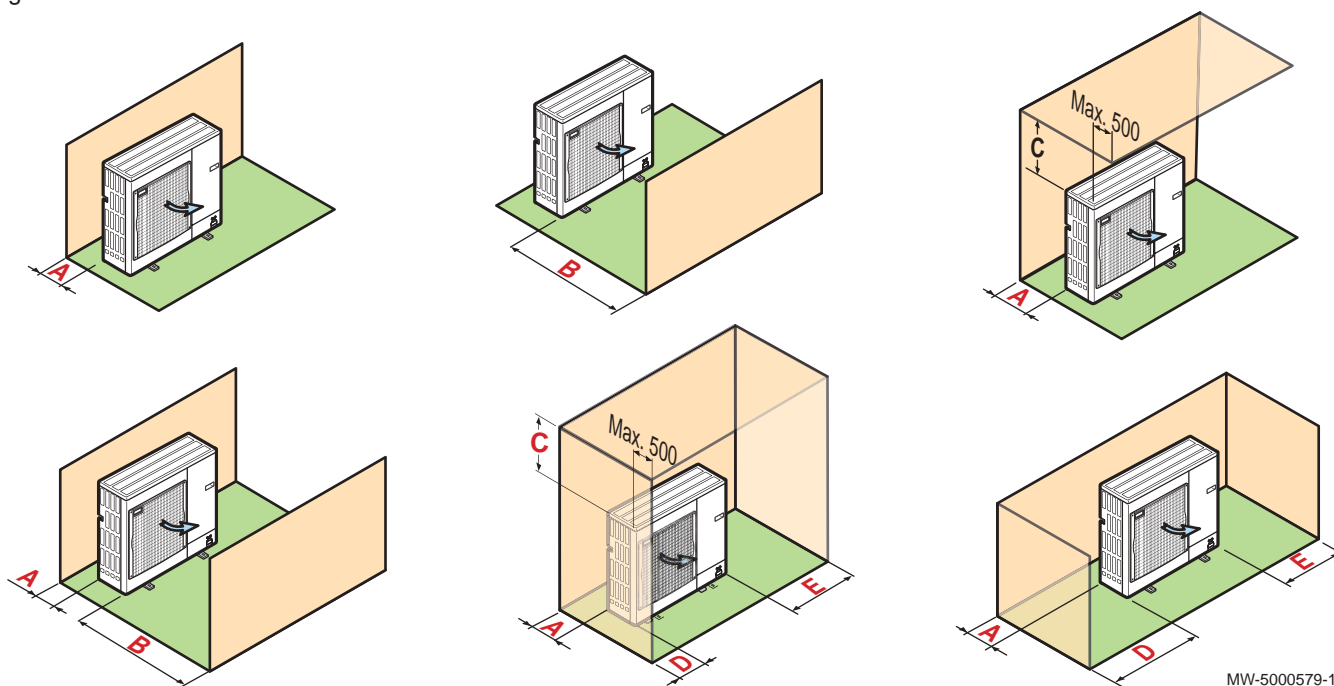

1. Respect the minimum positioning distances of the outdoor unit from the wall.

Tab.21 Minimum distances in mm

	A	B	C	D	E
AWHP 4.5 MR	100	500	1000	200	300
AWHP 6 MR-3	100	500	1000	200	300
AWHP 8 MR-2	100	500	1000	200	300

### 6.5.2 Selecting the location of the outdoor unit

Fig.23

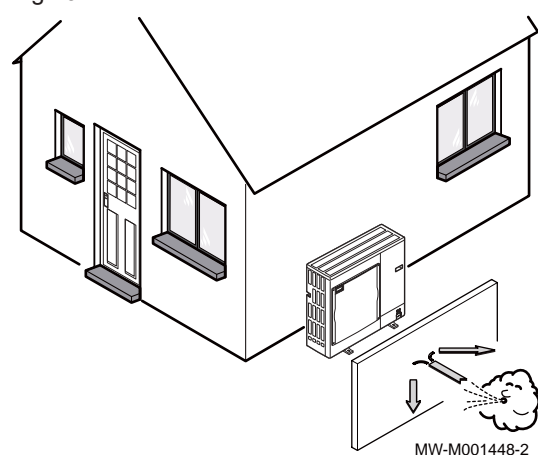

To ensure the outdoor unit operates correctly, its location must meet certain conditions.

1. Decide on the ideal location for the outdoor unit, bearing in mind the space it requires and any legal directives.
2. Observe the IP24 protection rating of the outdoor unit during installation.
3. Avoid the following locations as the outdoor unit is source of noise:
  - Prevailing winds
  - Close to sleep zones
  - Close to a terrace
  - Opposite a wall with windows
4. Nothing must obstruct the free circulation of air around the outdoor unit (intake and outlet).

5. Ensure the support meets the following specifications:
  - Flat surface that can support the weight of the outdoor unit and its accessories (concrete base, concrete blocks or sill).
  - No rigid connection to the building served to avoid the transmission of vibration.
  - Sufficient above ground elevation (200 mm) to keep it above water, ice and snow.
  - Base with a metal frame to allow condensates to be discharged correctly.



**Important**

- The width of the base must not exceed the width of the outdoor unit.
- The condensates discharge must be regularly cleaned in order to prevent any blockages.

**6.5.3 Choosing the location of a noise abatement screen**

When the outdoor unit is too close to neighbours, a noise abatement screen can be fitted to reduce noise pollution.

Install this type of equipment in compliance with prevailing legislation and standards.

Fig.24

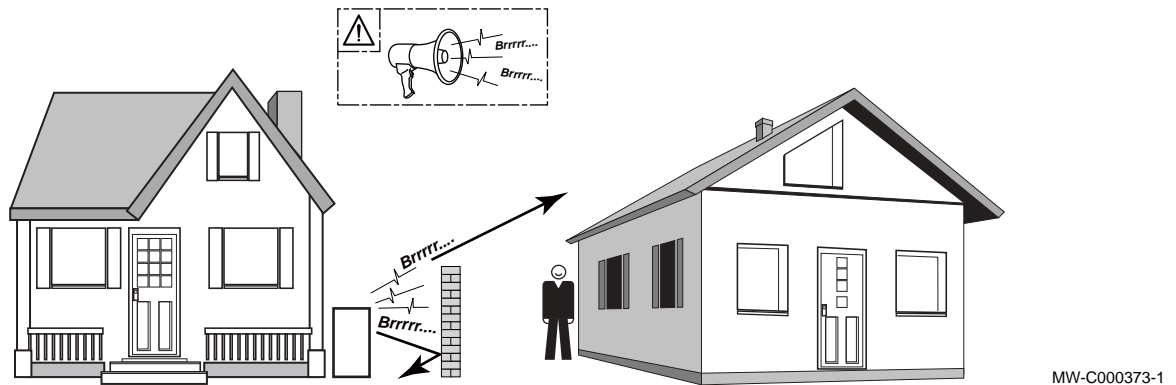

1. Locate the noise abatement screen as close as possible to the source of noise whilst allowing for the free circulation of air in the exchanger on the outdoor unit and maintenance work.
2. Respect the minimum positioning distances of the outdoor unit from the noise abatement screen.

**6.5.4 Selecting the location of the outdoor unit in cold and snowy regions**

Wind and snow can significantly reduce the performance of the outdoor unit. The location of the outdoor unit must meet the following conditions.

Fig.25



1. Install the outdoor unit sufficiently high off the ground to allow condensates to be discharged correctly.

2. Ensure the base meets the following specifications:

Specifications	Reason
Maximum width equal to the width of the outdoor unit.	
Height at least 200 mm greater than the average depth of the covering of snow.	This helps to protect the exchanger from snow and prevent the formation of ice during the defrosting operation.
Location as far as possible from the thoroughfare.	The condensates discharge may freeze, causing a potential hazard (sheet of black ice).

3. If the outdoor temperatures drop below zero, take the necessary precautions to prevent the risk of freezing in the evacuation pipes.
4. Place the outdoor units beside each other and not on top of each other to prevent the condensates from the lower unit to freeze.

### 6.5.5 Installing the outdoor unit on the ground

When installing on the ground, a concrete base must be installed, with no rigid connection to the building served to avoid the transmission of vibrations. Position a rubber floor support.

1. Dig a run-off channel with a pebble bed.
2. Install a concrete base frame with a minimum height of 200 mm capable of bearing the weight of the outdoor unit.
3. Install the outdoor unit on the concrete base frame.

Fig.26

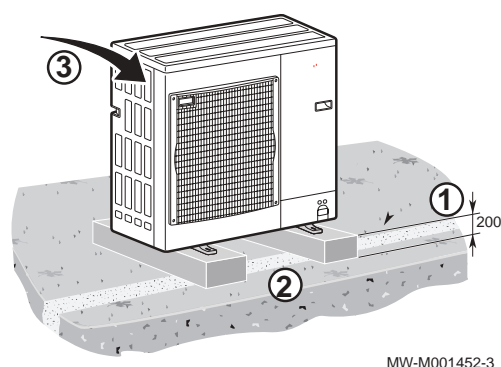

## 6.6 Hydraulic connections

### 6.6.1 Special precautions for the connection of the heating circuit

- During connection, it is imperative that the standards and corresponding local directives be respected.
- Depending on the heating system installation, install a filter on the heating return circuit.
- Depending on the heating system installation, install a sludge collector or a magnetic filter and/or additional mechanical filter on the heating return, just before the heat pump, if necessary.
- If components made from composite materials are used (polyethylene connection pipes or flexible hose), we recommend components with an anti-oxygen barrier.

### 6.6.2 Connecting the heating circuit

Heating installations must be able to guarantee a minimum flow rate at all times.



#### Important

To ensure maintenance and accessibility to the various components in the module, the hydraulic pipes have been purposely designed with a degree of play. This play is necessary and controlled. This pipe design guarantees the leak-tightness of the product.

1. Make the hydraulic connections between the indoor unit and the heating circuit.
2. Install an automatic air vent at the highest point on the heating circuit.

Fig.27

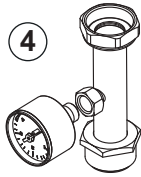

MW-1001199-1

3. Calculate the volume of water in the heating circuit and check the volume of the appropriate expansion vessel. Use the maximum temperature of the circuit in heating mode or, failing that, a minimum of 55 °C. If the volume of the integrated 10-litre expansion vessel is not sufficient, add an external vessel to the heating circuit. Refer to the applicable local and national regulations.
4. Connect the heating return for the indoor unit. Place the pressure gauge and its pipe on the heating return. The pressure gauge is supplied with the indoor unit.
5. Connect the heating flow for the indoor unit.

**Caution**

To avoid twisting the pipes inside the appliance, hold the nuts on the indoor unit side using a spanner.

Fig.28

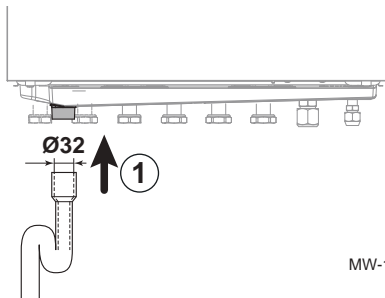

MW-1001200-1

### 6.6.3 Connecting the safety valve drain pipe

1. Connect the outlet pipe to the waste water discharge.

**Caution**

The discharge pipe in the safety valve or unit must not be blocked.

## 6.7 Refrigeration connections

### 6.7.1 Preparing the refrigerant connections

**Danger**

Only a qualified professional may carry out the installation in conformity with current legislation and standards.

To allow exchanges between the indoor module and the outdoor unit, fit 2 refrigerant connections: flow and return.

Pursuant to European Regulation 517/2014, the equipment must be installed by a certified operator whenever the refrigerant load is in excess of 5 tonnes of CO<sub>2</sub> equivalent or when a refrigerant connection is necessary (the case with split systems, even when fitted with a quick coupling device).

1. Install the refrigerant connection pipes between the indoor module and the outdoor unit.
2. Respect the minimum curve radii of 100 to 150 mm.
3. Adhere to the minimum and maximum distances between the indoor module and the outdoor unit.
4. Cut the pipes with a pipe cutter and deburr.
5. Angle the opening in the pipe downwards to ensure no particles can get inside, while preventing oil traps.
6. If the pipes are not connected immediately, plug them to prevent moisture from entering.



6.7.2 Connect the refrigerant connections to the indoor unit

Fig.29

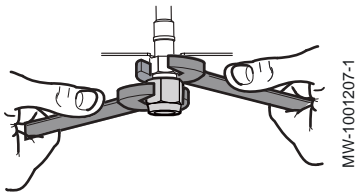

**Caution**  
Keep the refrigerant connection in place on the indoor unit with a spanner so as not to twist the internal pipe.

Fig.30

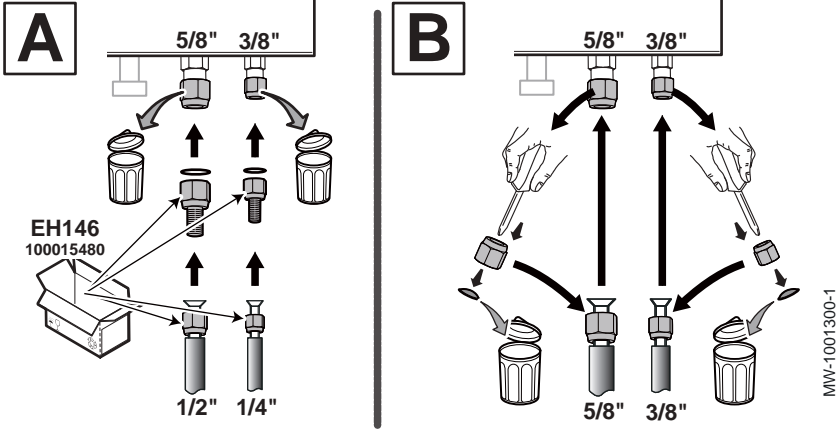

Tab.22

Association with an outdoor unit	Indoor unit gas line fitting	Indoor unit liquid line fitting
A: 4.5 and 6 kW	<ul style="list-style-type: none"> <li>• 5/8" &lt;=&gt; 5/8" to 1/2" adapter from package EH146 &lt;=&gt; 1/2" nut from package EH146</li> <li>• Discard the original 5/8" nut</li> </ul>	<ul style="list-style-type: none"> <li>• 3/8" &lt;=&gt; 3/8" to 1/4" adapter from package EH146 &lt;=&gt; 1/4" nut from package EH146</li> <li>• Discard the original 3/8" nut</li> </ul>
B: 8	<ul style="list-style-type: none"> <li>• 5/8" &lt;=&gt; Original 5/8" nut</li> <li>• Remove and discard the cap</li> </ul>	<ul style="list-style-type: none"> <li>• 3/8" &lt;=&gt; Original 3/8" nut</li> <li>• Remove and discard the cap</li> </ul>

Fig.31

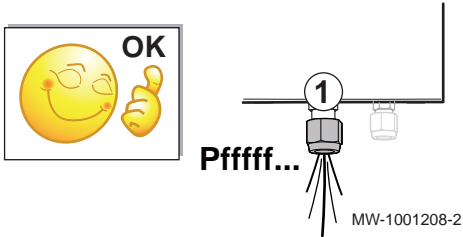

1. Check the exchanger leak-tightness: partially unscrew the "gas" nut.  
⇒ A release noise should be heard, which is proof that the exchanger is watertight.
2. Undo the nuts on the indoor unit.
3. Fit the connections as shown in the above table, using the copper gaskets for the adapters and adhering to the torque load.

Tab.23 Tightening torque applied

External diameter of the pipe (mm/inch)	External diameter of the cone fitting (mm)	Torque load (N.m)
6.35 - 1/4	17	14 - 18
9.52 - 3/8	22	34 - 42
12.7 - 1/2	26	49 - 61
15.88 - 5/8	29	69 - 82
19.05 - 3/4	36	100 - 120

4. Bead the pipes.
5. Connect the pipes and tighten the nuts, adhering to the torque load and applying refrigerant oil to the beaded parts to facilitate tightening and improve leak-tightness.

Fig.32

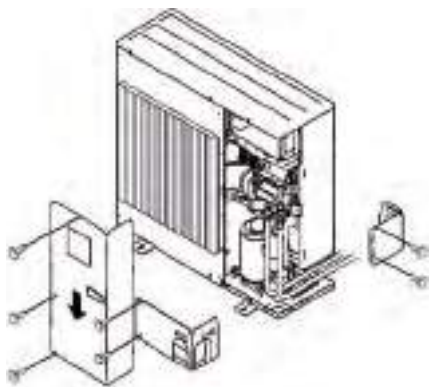

MW-5000512-2

### 6.7.3 Connecting the refrigerant connections to the outdoor unit

1. Remove the protective side panels from the outdoor unit.
2. Unscrew the nuts on the stop valves.

**Caution**

Keep the refrigerant connection in place on the outdoor unit with a spanner so as not to twist the internal pipe.

Fig.33

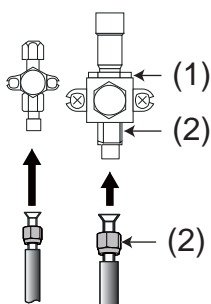

MW-1001302-2

- (1) Do not use a spanner on this part of the valve, there is a danger of the refrigerant leaking.
  - (2) Recommended position of the spanners for tightening the nut.
3. Thread the nuts onto the pipes.
  4. Bead the pipes.
  5. Apply refrigerant oil to the beaded parts to facilitate tightening and improve the seal.
  6. Connect the pipes and tighten the nuts with a torque wrench.

**Caution**

Keep the refrigerant connection in place on the outdoor unit with a spanner so as not to twist the internal pipe.

Tab.24 Torque load

External diameter of the pipe (mm/inch)	External diameter of the cone fitting (mm)	Torque load (N.m)
6.35 - 1/4	17	14 - 18
9.52 - 3/8	22	34 - 42
12.7 - 1/2	26	49 - 61
15.88 - 5/8	29	69 - 82
19.05 - 3/4	36	100 - 120

### 6.7.4 Adding the necessary quantity of refrigerant fluid

If the refrigerant connection pipes exceed the lengths below, add refrigerant fluid via the refrigerant fluid stop valve using a safety loader.

**Caution**

Prevent oil traps.

If the pipes are not connected immediately, plug them to prevent moisture from entering.

Tab.25 Quantity of refrigerant fluid to be added

Length of refrigeration pipe	7 m	10 m	15 m	20 m	30 m	Yg/m
AWHP 4.5 MR <sup>(1)</sup>	0	+ 0.045 kg	+ 0.120 kg	+ 0.195 kg	+ 0.345 kg	15 <sup>(2)</sup>

(1) The outdoor unit is pre-charged with 1.3 kg of refrigerant fluid.  
 (2) Calculation:  $Xg = Yg/m \times (\text{pipe length (m)} - 7)$

Tab.26 Quantity of refrigerant fluid to be added

Length of refrigeration pipe	11 to 20 m	21 to 30 m	31 to 40 m	41 to 50 m	51 to 60 m	61 to 75 m
AWHP 6 MR-3	0.2 kg	0.4 kg	0.6 kg	not permitted	not permitted	not permitted
AWHP 8 MR-2	0.15 kg	0.3 kg	0.9 kg	not permitted	not permitted	not permitted

### 6.7.5 Testing the leak-tightness of the refrigerant connections

Fig.34

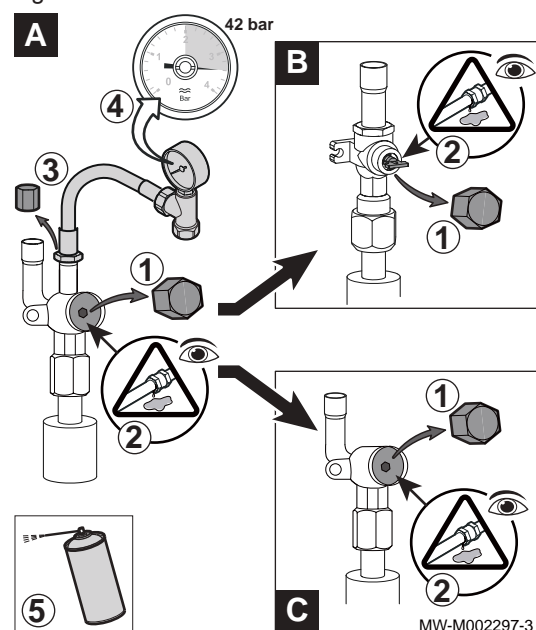

1. Remove the plugs from the stop valves **A** and **B / C**.
2. Check that **A** and **B / C** stop valves are closed.
3. Remove the plug from the service connection on **A** stop valve.
4. Connect the pressure gauge and the nitrogen bottle to the stop valve **A** then progressively build up the pressure in the refrigerant connection pipes and the indoor module to 42 bar, in 5 bar increments.
5. Check the leak-tightness of the fittings using a leak detector spray. If leaks appear, repeat the steps in order and check the leak-tightness once again.
6. Release the pressure and release the nitrogen.

### 6.7.6 Evacuation

Perform evacuation after checking that the refrigerant circuit is entirely free of leaks. Evacuation is necessary to remove air and moisture from the refrigerant circuit.

1. Check that the **A** and **B / C** stop valves are closed.
2. Connect the vacuum gauge and the vacuum pump to the service connection on **A** stop valve.
3. Produce a vacuum in the indoor module and the refrigerant connection pipes.
4. Check the pressure according to the recommendations table below:

Tab.27

Outdoor temperature	°C	≥ 20	10	0	- 10
Pressure to be reached	Pa (bar)	1000 (0.01)	600 (0.006)	250 (0.0025)	200 (0.002)
Evacuation time after reaching the pressure	h	1	1	2	3

5. Close the valve between the vacuum gauge / vacuum pump and **A** stop valve.
6. Disconnect the vacuum gauge and the vacuum pump after it has shut down.
7. Open the valves.

Fig.35

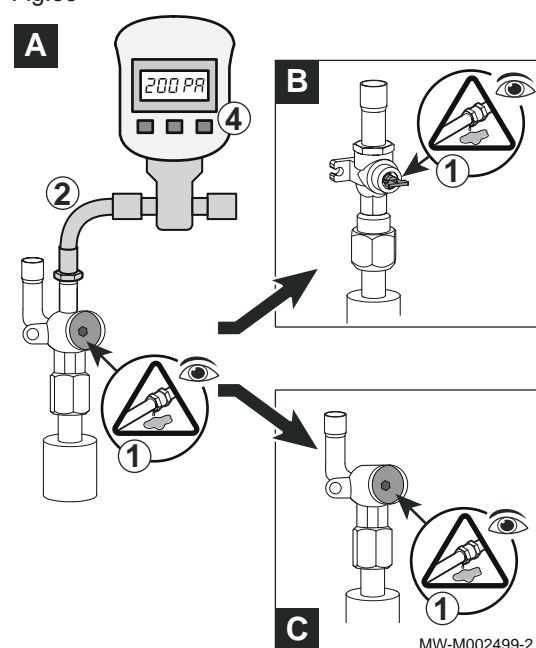
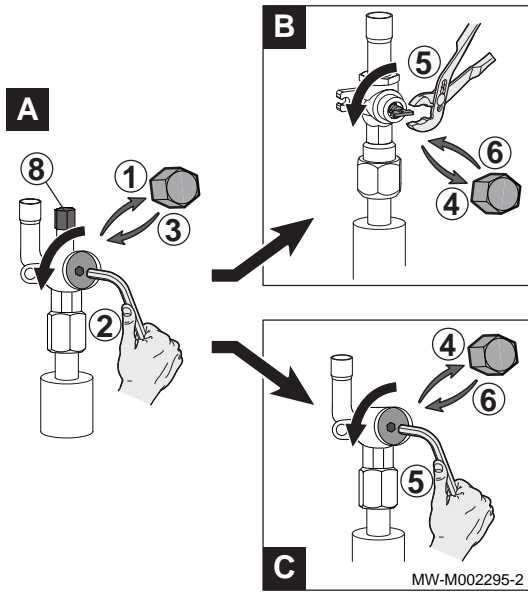

Fig.36



### 6.7.7 Opening the stop valves

Once the leak-tightness has been checked and the refrigerant circuit evacuated, open the stop valves to allow the refrigerant fluid to circulate.

1. Remove the cap from the refrigerant fluid stop valve, fluid end.
2. Open valve **A** with a hexagonal spanner by turning anti-clockwise until it stops.
3. Put the cap back in place.
4. Remove the cap from refrigerant gas stop valve **B** or **C**.
5. Open the valve.

Valve B	Open the valve with pliers by turning it a quarter turn anti-clockwise.
Valve C	Open the valve with a hexagonal spanner by turning anti-clockwise until it stops.

6. Put the cap back in place.
7. Put the cap back in place on valve **A**.
8. Tighten all the caps with a torque wrench with a torque load of 20 to 25 N·m.
9. Depending on the length of the refrigerant pipes, it may be necessary to add refrigerant fluid.

## 6.8 Electrical connections

### 6.8.1 Recommendations



**Warning**

- Only qualified professionals may carry out electrical connections, always with the power off.
- Earth the appliance before making any electrical connections.

- Make the electrical connections on the appliance in accordance with the requirements of the prevailing standards,
- Make the electrical connections on the appliance in accordance with the information given in the electrical schematics delivered with the appliance,
- Make the electrical connections on the appliance in accordance with the recommendations of these instructions.



**Important**

Earthing must comply with the prevailing installation standards.



**Caution**

- The installation must be fitted with a main switch.



**Caution**

Power the appliance via a circuit that includes an omnipolar switch with contact opening distance of 3 mm or more.

- Single phase models: 230 V (+6%/-10%) 50 Hz

When making electrical connections to the mains, respect the following polarities.

Tab.28

Colour of the wire	Polarity
Brown wire	Live
Blue wire	Neutral
Green/yellow wire	Earth

**Caution**

Secure the cable with the cable clamp provided. Be careful that you do not invert any of the wires.

**6.8.2 Recommended cable cross section**

The electrical characteristics of the mains power supply available must correspond to the values given on the data plate.

The cable will be carefully chosen according to the following information:

- Maximum intensity of the outdoor unit. See table below.
- Distance of the appliance from the original power supply.
- Upstream protection.
- Neutral operating conditions.

**Important**

The maximum permissible current on the power supply cable of the indoor unit must not exceed 6 A.

Tab.29

Appliance	Power supply type	Cable cross section (mm <sup>2</sup> )	Circuit breaker curve C (A)	Maximum amperage (A)
Indoor unit	Single phase	Cable provided (3 x 1.5)	10	-
Electrical back-up	Single phase	3 x 6	32	-
	Three phase	5 x 2.5	16	-
BUS cable <sup>(1)</sup>	-	2 x 0.75	-	-
AWHP 4.5 MR	Single phase	3 x 2.5	16	12
AWHP 6 MR-3	Single phase	3 x 2.5	16	13
AWHP 8 MR-2	Single phase	3 x 4	25	17

(1) Connection cable linking the outdoor unit to the indoor unit

6.8.3 Routing the cables



**Caution**

Separate the sensor cables from the 230/400 V circuit cables. Secure all the cables exiting the indoor unit using the traction arrester devices supplied in the accessories bag.

Fig.37

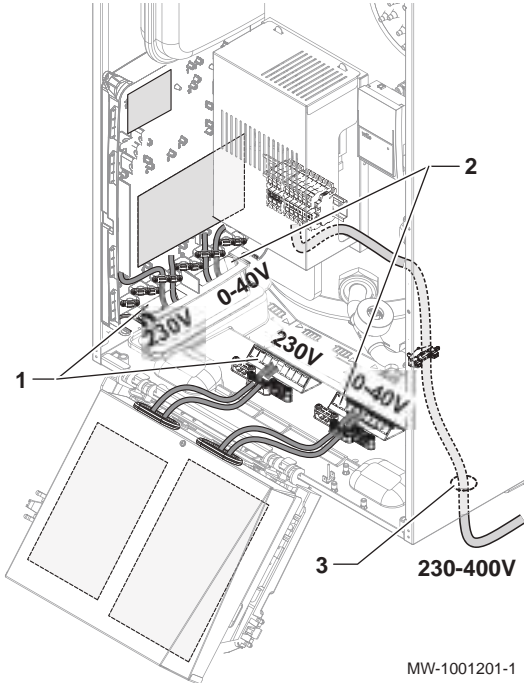

- 1 230 V~ circuit cables
- 2 0-40 V safety extra-low voltage cables
- 3 230 - 400 V electrical back-up power supply cables (only for models with an electrical back-up)

6.8.4 Description of the connection terminal blocks

■ Possible connections

Several heating zones can be connected to the EHC-05 and SCB-10 PCBs. The options can be increased with the optional AD249 PCB.

The connections for the sensors or pumps of each zone are on each PCB.

Tab.30

Circuits	CIRCA0 (EHC-05)	DHW (EHC-05)	CIRCA1 (SCB-10)	CIRCB1 (SCB-10)	CIRCC1 (with AD249 option)	CIR-CAUX1 (with AD249 option)	DHW1 (SCB-10)
Convection fan	X		X	X	X		
Underfloor heating	X <sup>(1)</sup>		X	X	X		
Radiator	X		X	X	X		
365 day radiator	X		X	X	X		
Continuous heating	X		X	X	X		
Timer programme			X	X	X	X	X
Swimming pool			X	X	X		
Domestic hot water production		X	X	X	X	X	X
Domestic hot water production, electric only		X	X	X	X		
Stratified tank (2 sensors)		X					X
Buffer tank used as a low-loss header	X	X	X	X	X	X	X

Circuits	CIRCA0 (EHC-05)	DHW (EHC-05)	CIRCA1 (SCB-10)	CIRCB1 (SCB-10)	CIRCC1 (with AD249 op- tion)	CIR- CAUX1 (with AD249 op- tion)	DHW1 (SCB-10)
Buffer tank for storage				X			
Deactivation	X	X	X	X	X	X	X
(1) Use the direct zone underfloor heating option							

### ■ Description of the EHC-05 PCB

Fig.38

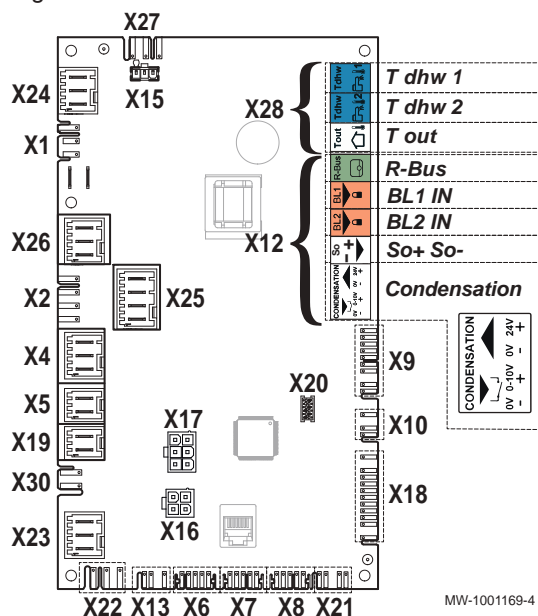

- X1** Main power supply for the 230 V - 50 Hz indoor module
- X4**
  - Hydraulic version: Hydraulic back-up pump
  - Electrical version: Electrical back-up - stage 1
- X5**
  - Hydraulic version: Hydraulic back-up ON/OFF contact
  - Electrical version: Electrical back-up - stage 2
- X7** Local communication bus to the SCB-10 PCB
- X8** Control panel display for the indoor module
- X9** Sensors
- X10** Speed control signal for the heat pump circulating pump
- X12** Options
  - R-Bus: Baxi uSense connected room thermostat, on/off thermostat, modulating thermostat or OpenTherm thermostat for the CIRCA0 direct zone
  - BL1 / BL2: multifunction inputs
  - So+/So- : Electric energy meter
  - Condensation: condensation sensor
- X15** Not used
- X16** Not used
- X17** Not used
- X18** Input/output for the HPC-01 PCB
- X19** Control signal for the immersion heater on the domestic hot water tank
- X22** Bus for communication with the outdoor unit HPC-01 PCB
- X23** Bus for communicating with the outdoor unit
- X24** Not used
- X25** Heating reversing valve: **CIRCA0** /Domestic hot water: **DHW**
- X26** **CIRCA0** direct heating circuit pump
- X27** Heat pump circulating pump power supply
- X28** Temperature sensor:
  - T dhw 1: Temperature sensor at the bottom of the **DHW** domestic hot water tank (optional)
  - T dhw 2: Temperature sensor at the top of the **DHW** tank
  - T out: not used

■ Description of the SCB-10 PCB

Fig.39

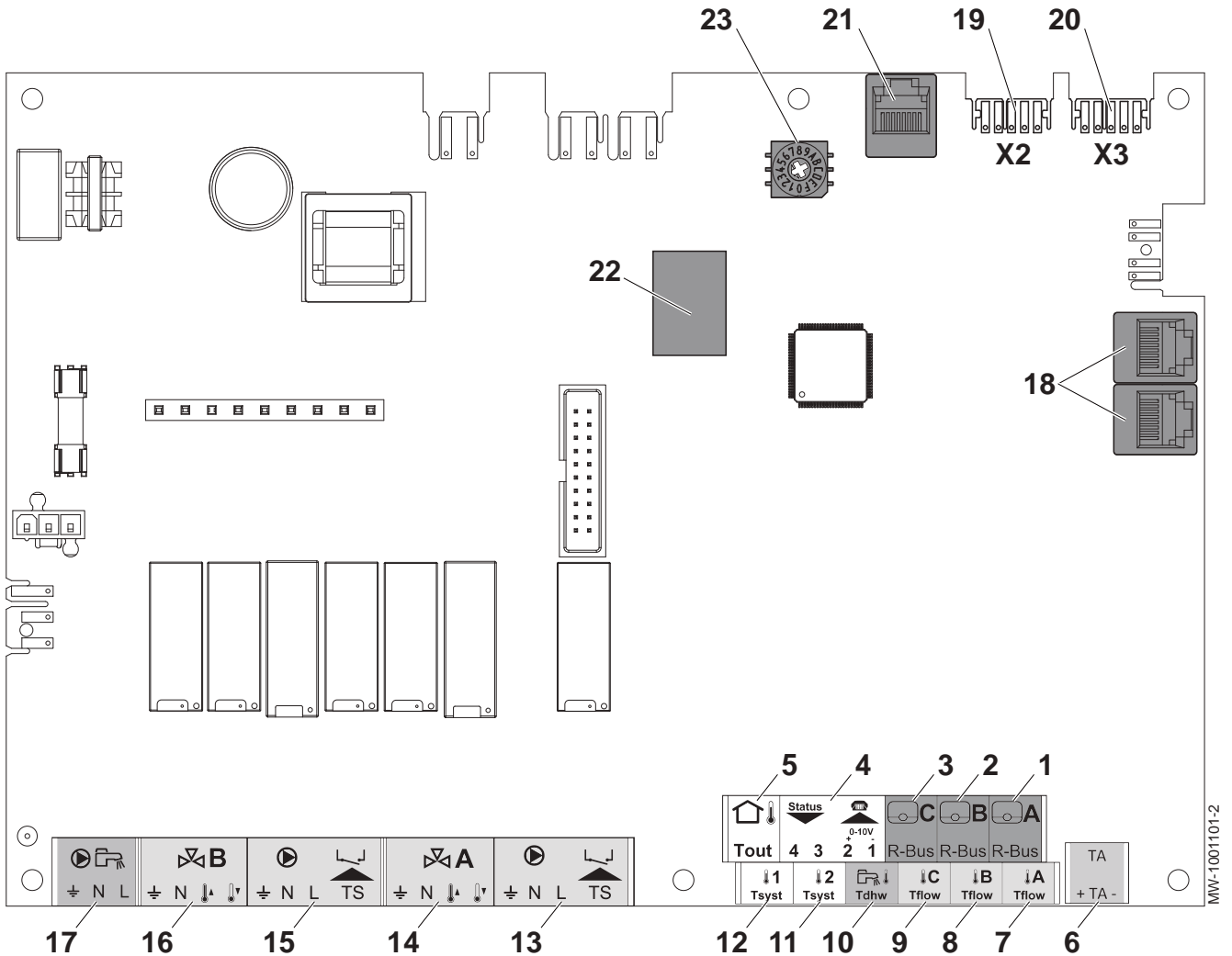

- 1 R-Bus: Baxi uSense connected room thermostat, on/off thermostat, modulating thermostat or OpenTherm thermostat - **CIRCA1** circuit
- 2 R-Bus: Baxi uSense connected room thermostat, on/off thermostat, modulating thermostat or OpenTherm thermostat - **CIRCB1** circuit
- 3 R-Bus: Baxi uSense connected room thermostat, on/off thermostat, modulating thermostat or OpenTherm thermostat - **CIRCC1** circuit
- 4 Programmable and 0-10 V input
- 5 Outdoor temperature sensor
- 6 Impressed current anode
- 7 Flow sensor - **CIRCA1** circuit
- 8 Flow sensor - **CIRCB1** circuit
- 9 Flow sensor - **CIRCC1** circuit
- 10 Domestic hot water sensor on the **DHW1** second domestic hot water circuit
- 11 System sensor 2
- 12 System sensor 1
- 13 Pump and safety thermostat - **CIRCA1** circuit
- 14 Three-way valve - **CIRCA1** circuit
- 15 Pump and safety thermostat - **CIRCB1** circuit
- 16 Three-way valve - **CIRCB1** circuit
- 17 Domestic hot water tank pump when using a second domestic hot water circuit
- 18 Connectors for S-BUS cables used for cascade
- 19 L-BUS connection
- 20 L-BUS connection to EHC-05 PCB
- 21 Tool service connector
- 22 ConnectorsMod-BUS
- 23 Coding wheel, selects the generator number in the cascade

■ Description of the three-way valve and auxiliary circuit AD249 PCB

PCB AD249 is an additional board which is connected to the SCB-10 PCB to enable it to control a third heating circuit and auxiliary functions.



Fig.40

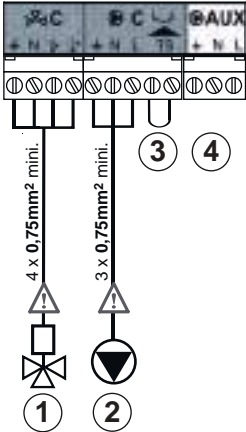

MW-1001681-1

- 1 CIRCC1 three-way valve
- 2 CIRCC1 circuit pump
- 3 CIRCC1 safety thermostat. Factory fitted bridge
- 4 CIRC AUX1 auxiliary pump

6.8.5 Accessing the PCBs

Fig.41

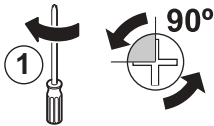
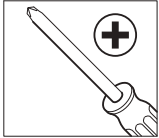
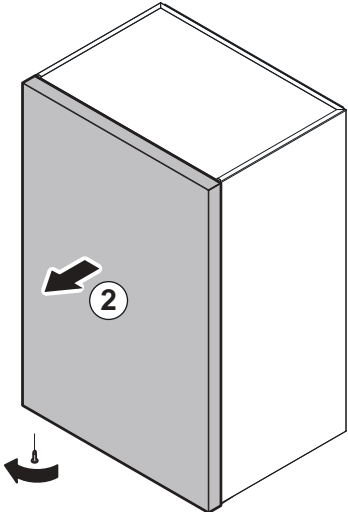

MW-1001203-1

- 1. Unscrew the two screws under the front panel by a quarter turn.
- 2. Remove the front panel.

Fig.42

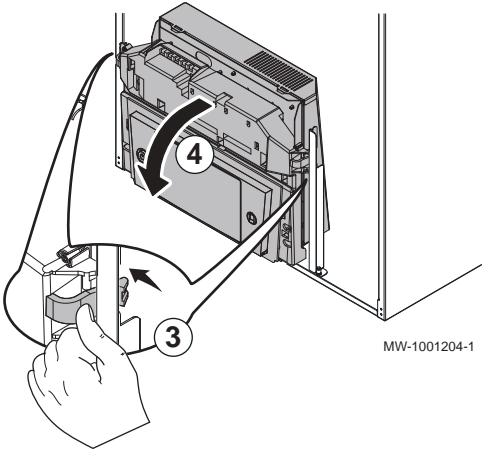

MW-1001204-1

- 3. Open the holding clips located on the sides.
- 4. Tilt the control panel forwards.

Fig.43

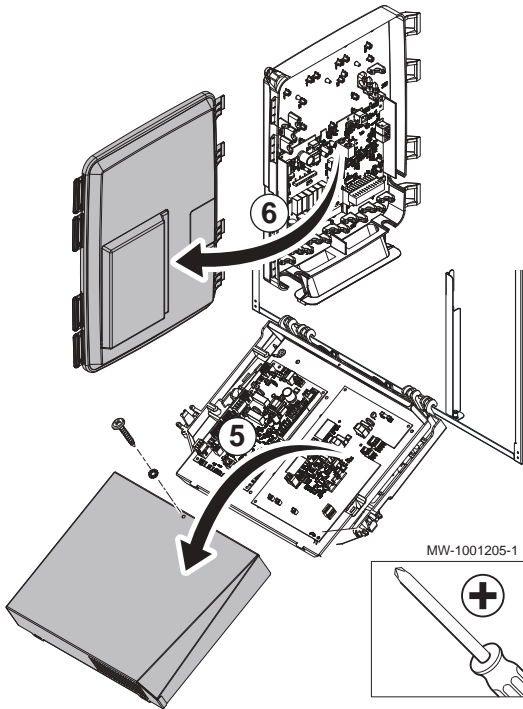

5. Remove the screw and the control panel cover.
6. Unclip the PCB cover.

Fig.44

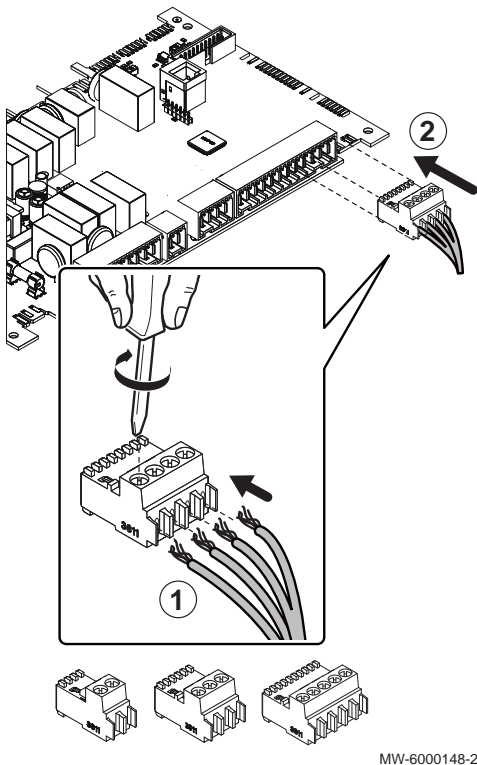

### 6.8.6 Connecting the cables to the PCBs

Keyed connectors are present on different terminal blocks as standard. Use these to connect the cables to the PCBs. If there are no connectors on the terminal block to be used, take the connector provided with the kit.

Coloured stickers are provided with certain accessories. Use these to mark each end of the cable with the same colour before passing the cables into the cable feed-throughs.

1. Insert and screw down the wires in the corresponding connector inputs.
2. Insert the connector into the corresponding terminal block.
3. Feed the cable into the cable duct and adjust the length of the cable accordingly.
4. Lock it in position with a cable clamp or a traction arrester device.

**Caution**  
 Danger of electric shock: the length of the conductors between the traction arrester device and the terminal blocks must be such that the active conductors are put under tension before the earth conductor.

6.8.7 Electrically connecting the outdoor unit

Fig.45

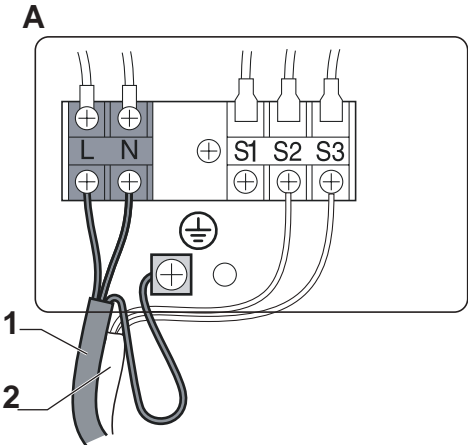

- 1 Power supply
- 2 Communication bus

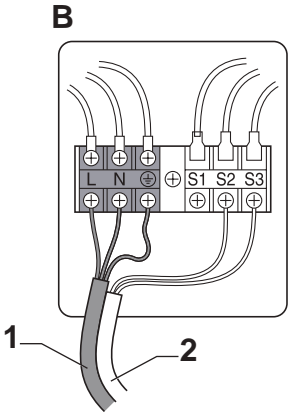

- A AWHP 4.5 MR
- B AWHP 6 MR-3 / AWHP 8 MR-2

MW-1001351-1

Fig.46

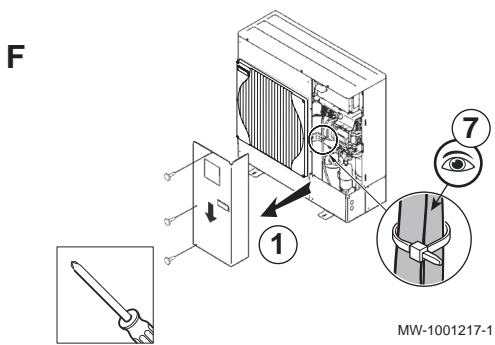
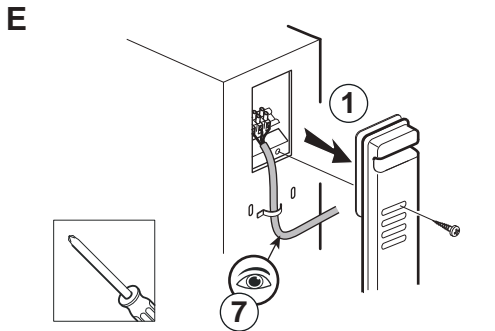
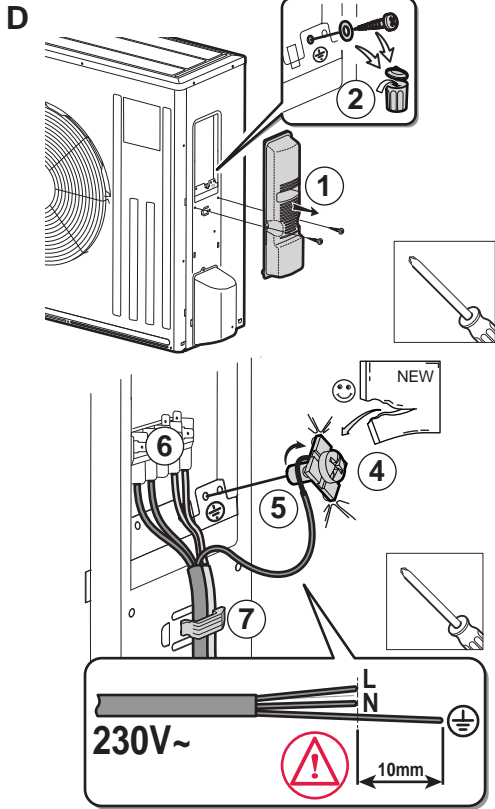

MW-1001217-1

- D AWHP 4.5 MR
- E AWHP 6 MR-3
- F AWHP 8 MR-2

1. Remove the service panel.
2. AWHP 4.5 MR only: remove the earth connection screw from the appliance and discard.
3. Check the cross-section of the cable used, as well as its protection in the electric panel.
4. AWHP 4.5 MR only: secure the screw and square washer provided on the stripped part of the earth wire (⊕).

**Danger**  
 The stripped part of the earth wire must be fitted underneath the washer against the base frame.

5. Connect the earth wire.

**Danger**  
 The earth wire must be 10 mm longer than the N and L wires.

6. Connect the cables to the appropriate terminals.
7. Feed the cable into the cable duct and adjust the length of the cable accordingly. Lock it in position with a cable clamp or a traction arrester device.

**Caution**  
 Danger of electric shock: the length of the conductors between the traction arrester device and the terminal blocks must be such that the active conductors are put under tension before the earth conductor.

### 6.8.8 Connecting the indoor module

1. Remove the front panel of the casing.
2. Fit the cable clamps and run the cables through the cable clamps.
3. Connect the power supply cable to the electric panel.
4. Connect the various components to the corresponding terminals on the indoor module.
5. Connect the electrical back-up.
6. Tighten the cable clamps.
7. Put the front panel back in place.

Fig.47

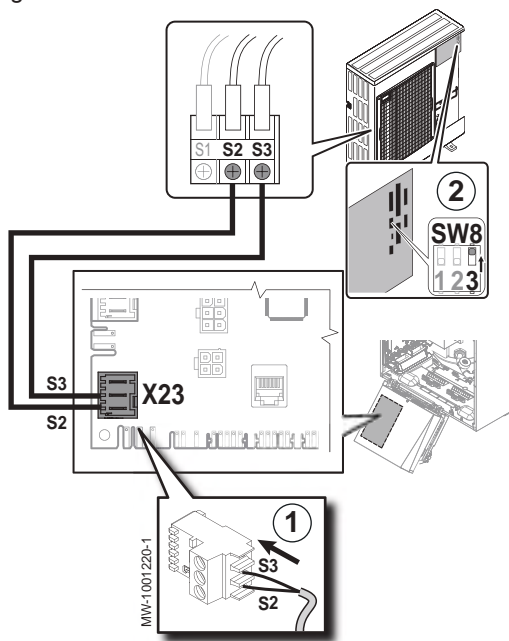

### 6.8.9 Connecting the outdoor unit bus

1. Connect the outdoor unit bus between the S2 and S3 terminals on the **X23** connector in the indoor unit's **EHC-05** central unit PCB.
2. Position the **SW8-3** switch (except for AWHP 4.5 MR) for the outdoor unit PCB to **ON**.



#### Danger

Do not connect anything to S1.

### 6.8.10 Fitting the outdoor sensor

Fig.48

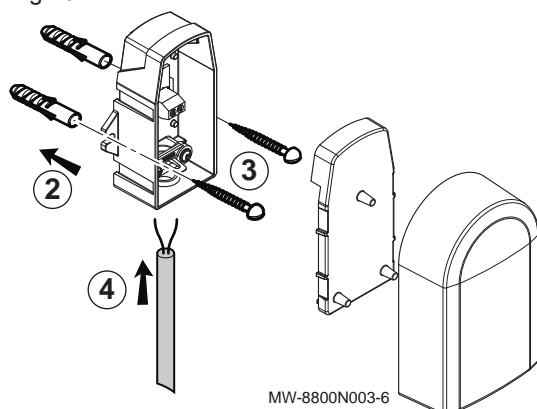

Plugs diameter 4 mm/drill diameter 6 mm

1. Choose a recommended location for the outdoor sensor.
2. Put the 2 plugs in place, delivered with the sensor.
3. Secure the sensor using the screws provided (diameter 4 mm).
4. Connect the cable to the outdoor temperature sensor.

#### ■ Recommended positions

Place the outside sensor in a position that covers the following characteristics:

- On a façade of the area to be heated, on the north if possible.
- Half way up the wall of the area to be heated.
- Under the influence of changes in the weather.
- Protected from direct sunlight.
- Easy to access.

Fig.49

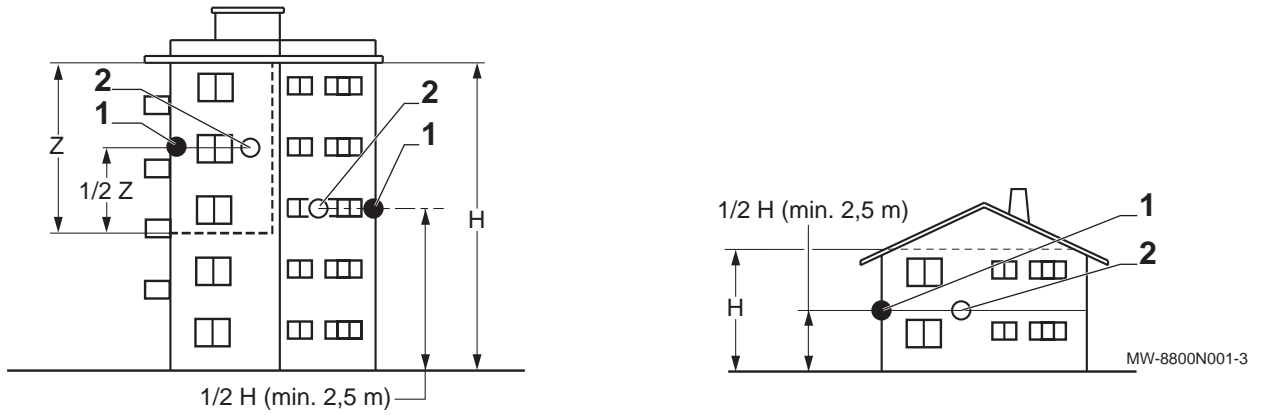

- 1 Optimum location
- 2 Possible position

- H Inhabited height controlled by the sensor
- Z Inhabited area controlled by the sensor

■ Positions to be avoided

Avoid placing the outside sensor in a position with the following characteristics:

- Masked by part of the building (balcony, roof, etc.).
- Close to a disruptive heat source (sun, chimney, ventilation grid, etc.).

Fig.50

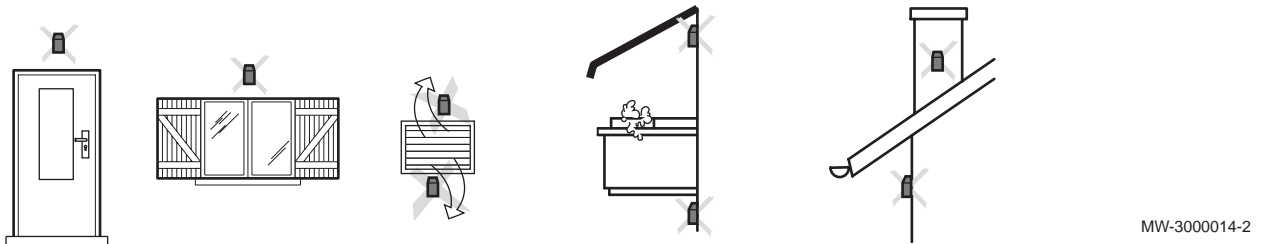
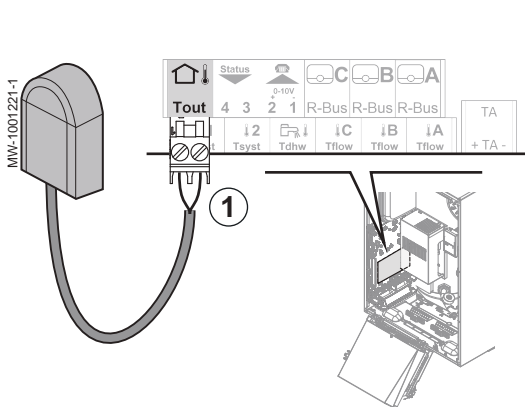

Fig.51



6.8.11 Connecting the outdoor temperature sensor

1. Connect the outdoor temperature sensor to the **T Out** input on the **SCB-10** PCB of the indoor unit.



**Important**

Use a cable with a minimum cross-section of 2x0.35 mm<sup>2</sup> and a maximum length of 30 m.

6.8.12 Connecting and configuring the electrical back-up

■ Accessing the indoor module terminal blocks

1. Remove the retaining screw.
2. Remove the protective cover.

Fig.52

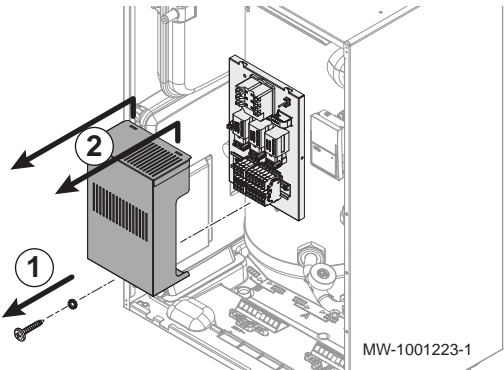

■ Connecting the electrical back-up to the indoor unit

**Caution**  
 The length of the conductors between the cable clamp and the terminals must be such that the active conductors are put under tension before the earth conductor.  
 Feed the electrical back-up heater power supply cable into the 230-V cable duct.  
 Adapt the length of the cables and check their positions with a cable clamp.

Fig.53

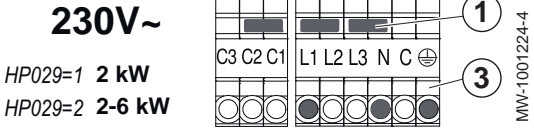

Single-phase connection

- A Bridge
- B Power supply

Fig.54

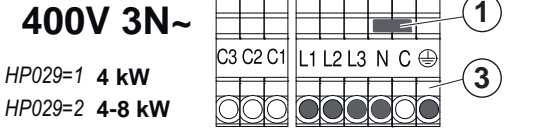

Three-phase connection

- A Bridge
- B Power supply

Press the orange push-button to allow the wire to be correctly inserted in the connector and locked.

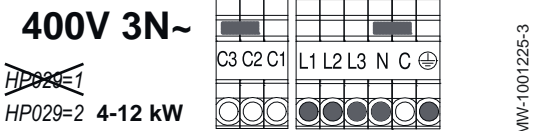
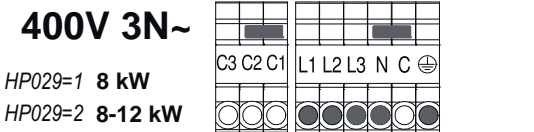

■ Configuring the output for the immersion heater

Tab.31

Power supply	Setting the Backup type (HP029) parameter	Bridge	Backup 1 capacity (HP034)	Backup 2 capacity (HP035)	Total output of back-up 1+2
Single phase	2 Electrical Stages	between C2 and C1	2 kW	4 kW	6 kW
	1 Electrical Stage	between C2 and C1	2 kW	not used	2 kW
Three phase	2 Electrical Stages	between C3 and C2	4 kW	8 kW	12 kW
		between C2 and C1	8 kW	4 kW	12 kW
		Remove bridge	4 kW	4 kW	8 kW
	1 Electrical Stage	between C2 and C1	8 kW	not used	8 kW
		Remove bridge	4 kW	not used	4 kW



Configure the heat pump parameters

Tab.32

Access	Parameter	Description	Adjustment required
<b>Air Src Heat pump &gt; Parameters, counters, signals &gt; Adv. Parameters</b>	Backup type (HP029)	Type of backup used in the heat pump	<ul style="list-style-type: none"> <li>• 1 Electrical Stage</li> <li>• 2 Electrical Stages</li> </ul>
	Backup 1 capacity (HP034)	Declaration of the capacity of the 1st stage of the electrical backup used for the energy counter	0 kW to 10 kW
	Backup 2 capacity (HP035)	Declaration of the capacity of the 2nd stage of the electrical backup used for the energy counter	0 kW to 10 kW

6.9 Connecting options

Fig.55

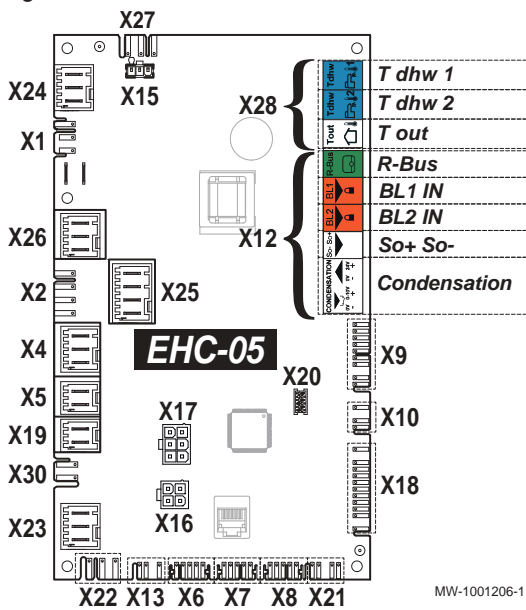

1. Connect the options according to the configuration of the installation to the X12 or X28 connector on the EHC-05 PCB in the indoor module.

Tab.33 Connecting the options to X28

X28 connector	Description
T dhw 1	Optional: Connection of a second domestic hot water sensor for domestic hot water tanks with two sensors. Top sensor.
T dhw 2	Connection of the main domestic hot water sensor: <ul style="list-style-type: none"> <li>• for tanks designed with a single sensor,</li> <li>• for domestic hot water tanks with two sensors. Bottom sensor.</li> </ul>
T out	Not used

Tab.34 Connecting the options to X12

X12 connector	Description
R-Bus terminals	Connection of the Baxi uSense connected thermostat, an on/off thermostat (ON/OFF) or a modulating thermostat.
BL1 IN and BL2 IN	Connection of multi-function dry contact inputs



X12 connector	Description
SO+/SO- input	Connection of an electrical energy meter
Condensation terminals	Connection of a condensation sensor for under-floor cooling

### 6.9.1 Connecting an on/off or modulating thermostat

The on/off or modulating thermostat is connected to the **R-Bus** terminals on the **EHC-05** PCB or the optional **SCB-10** PCB.

The PCBs are delivered with a bridge on the **R-Bus** terminals.

The **R-Bus** input can be configured to add the flexibility of using several types of on/off thermostat or OpenTherm (OT).



1. Configure the parameters for the circuit concerned:

Tab.35 Configuration of the **R-Bus** input for using an on/off thermostat (dry contact)

Access	Parameter	Description
CIRCA0, CIRCA1, CIRCB1 or CIRCC1 > Parameters, counters, signals > Parameters	OTH LogicLev contact (CP640, CP641, CP643)	Configuration of the on/off input contact direction for heating mode. <ul style="list-style-type: none"> <li>• Closed (default value): heating demand when contact is closed</li> <li>• Open: heating demand when contact is open</li> </ul>
	RevContactOTH cool (CP690, CP691, CP693)	Reversal of the direction of the logic in cooling mode compared to heating mode <ul style="list-style-type: none"> <li>• No (default value): cooling demand uses the same logic as the heating demand</li> <li>• Yes: cooling demand uses the reverse logic to the heating demand</li> </ul>

Tab.36 OTH LogicLev contact and RevContactOTH cool parameter settings

Value of the OTH LogicLev contact parameter (CP640, CP641, CP643)	Value of the RevContactOTH cool parameter (CP690, CP691, CP693)	Position of the on/off contact for heating	Position of the on/off contact for cooling
Closed (default value)	No (default value)	Closed	Closed
Open	No	Open	Open
Closed	Yes	Closed	Open
Open	Yes	Open	Closed

### 6.9.2 Configuring a thermostat with a heating/cooling control contact

The AC thermostat (air conditioning) is always connected to the **R-Bus** and **BL1** terminals on the **EHC-05** PCB. The AC thermostat is only compatible with configurations **with a single heating circuit**.

Priority will be given to the AC thermostat input over the other Summer/Winter modes (Auto/Manual).

The PCBs are delivered with a bridge on the R-BUS terminals.

1. Connect the AC thermostat to the **BL1** input on the **EHC-05** PCB.

- 1 EHC-05 PCB
- 2 Room unit
- 3 Output: On/Off
- 4 "Heating/cooling contact" output

Fig.56

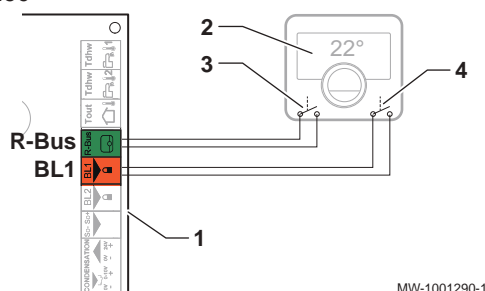

MW-1001290-1



2. Configure the heat pump parameters

Tab.37

Access	Parameter	Description	Adjustment re-quired
23.5 Air Src Heat pump > Parameters, counters, signals > Adv. Parameters	<b>BL function</b> (AP001)	BL input function selection	Heating Cooling
	<b>BL1 contact config.</b> (AP098)	BL1 input contact configuration Closed: function active when BL contact is closed Open: function active when BL contact is open	<ul style="list-style-type: none"> <li>• Closed</li> <li>or</li> <li>• Open</li> </ul>

Tab.38

Access	Parameter	Description	Adjustment re-quired
21.7 CIRCA0> Parameters, counters, signals > Parameters	<b>OTH LogicLev contact</b> (CP640)	Opentherm Logic level contact of the zone Closed: heating demand when contact is closed Open: heating demand when contact is open	<ul style="list-style-type: none"> <li>• Closed</li> <li>or</li> <li>• Open</li> </ul>
	<b>RevContactOTH cool</b> (CP690)	Reversed OpenTherm contact in cooling mode for heat demand per zone No: follows the heating logic Yes: follows the reverse of the heating logic	<ul style="list-style-type: none"> <li>• Yes</li> <li>or</li> <li>• No</li> </ul>

Tab.39 Configuration A - by default

Value of the OTH LogicLev contact (CP640) parameter	Value of the BL1 contact config. (AP098) parameter	The BL1 multifunction input is	Operating mode for the heat pump	If the OT contact is open	If the OT contact is closed
Closed (default value)	Closed (default value)	Open	Cooling	No cooling demand	Cooling demand
Closed (default value)	Closed (default value)	Closed	Heating	No heating demand	Heating demand

Tab.40 Configuration B

Value of the OTH LogicLev contact (CP640) parameter	Value of the BL1 contact config. (AP098) parameter	The BL1 multifunction input is	Operating mode for the heat pump	If the OT contact is open	If the OT contact is closed
Closed	Open	Open	Heating	No heating demand	Heating demand
Closed	Open	Closed	Cooling	No cooling demand	Cooling demand

Tab.41 Configuration C

Value of the OTH LogicLev contact (CP640) parameter	Value of the BL1 contact config. (AP098) parameter	The BL1 multifunction input is	Operating mode for the heat pump	If the OT contact is open	If the OT contact is closed
Open	Closed	Open	Cooling	Cooling demand	No cooling demand
Open	Closed	Closed	Heating	Heating demand	No heating demand

Tab.42 Configuration D

Value of the OTH LogicLev contact (CP640) parameter	Value of the BL1 contact config. (AP098) parameter	The BL1 multifunction input is	Operating mode for the heat pump	If the OT contact is open	If the OT contact is closed
Open	Open	Open	Heating	Heating demand	No heating demand
Open	Open	Closed	Cooling	Cooling demand	No cooling demand

## 6.10 Filling the heating circuit

Before filling the heating system, flush it thoroughly.

### Important

- The use of glycol to fill the heating circuit is formally prohibited.
- The use of glycol in the heating circuit invalidates the warranty.

1. Fill the installation until a pressure of 0.15 to 0.2 MPa (1.5 to 2 bar) is achieved.
2. Check for any water leaks.
3. Completely vent the indoor unit and the installation for optimum running.

### 6.10.1 Flushing new installations and installations less than 6 months old

Before filling the heating installation, it is essential to remove any debris (copper, caulking, soldering flux) from the installation.

1. Clean the installation with a powerful universal cleaner.
2. Flush the installation with at least 3 times the volume of water contained in the central heating system (until the water runs clear and shows no impurities).

### 6.10.2 Flushing an existing installation

Before filling the heating installation, it is essential to remove any sludge deposits which have accumulated in the heating circuit over the years.

1. Remove any sludge from the installation.
2. Flush the installation with at least 3 times the volume of water contained in the central heating system (until the water runs clear and shows no impurities).

## 6.11 Filling the installation

### 6.11.1 Treatment of the heating water

In many cases, the heat pump and the heating system can be filled with mains water, without treating the water.



#### Caution

Do not add any chemical products to the heating water without first consulting a water treatment specialist. For example: antifreeze, water softeners, products to increase or reduce the pH value, chemical additives and/or inhibitors. These may cause faults in the heat pump and damage the heat exchanger.

The water in the installation must comply with following characteristics:

Tab.43 Heating water specifications

Specifications	Unit	Total system output
		≤ 70 kW
Hydrogen potential (pH)		7.5 - 9
Conductivity at 25°C	µS/cm	10 to 500
Chlorides	mg/litre	≤ 50
Other components	mg/litre	< 1
Total water hardness	°f	7 - 15
	°dH	4 - 8.5
	mmol/l	0.7 - 1.5

If water treatment proves necessary, Baxi recommends the following manufacturers:

- Cillit
- Climalife
- Fernox
- Permo
- Sentinel

## 7 Commissioning

### 7.1 General

---

The heat pump is commissioned:

- When it is used for the first time;
- after a prolonged shutdown.

Commissioning of the heat pump allows the user to review the various settings and checks to be made to start up the heat pump in complete safety.

### 7.2 Checklist before commissioning

---

#### 7.2.1 Checking the heating circuit

---

1. Check the volume of the expansion vessel(s) is sufficient for the volume of water in the heating installation.
2. Check the inflation pressure of the expansion vessel(s).
3. Check that the heating circuit contains adequate water. If necessary, top up with more water.
4. Check that the water connections are properly sealed.
5. Check that the heating circuit has been correctly purged.
6. Check that the filters are not clogged. Clean them if necessary.
7. Check that the valves and thermostatic radiator valves are open.
8. Check that all settings and safety devices are working correctly.

#### 7.2.2 Checking the electrical connections

---

1. Check the mains electricity connection to the following components:
  - Outdoor unit
  - Indoor unit
  - Electrical back-up
2. Check that the BUS cable is correctly positioned between the indoor unit and the outdoor unit, and that it is separate from the power supply cables.
3. Check the conformity of the circuit breakers used:
  - Outdoor unit circuit breaker
  - Indoor unit circuit breaker
  - Electrical back-up circuit breaker
4. Check the positioning and connection of the sensors:
  - Room temperature sensor (if present)
  - Outdoor temperature sensor
  - Flow sensor for the second circuit (if present)
5. Check the connection of the circulating pump(s).
6. Check that the wires and terminals are properly tightened or connected to the terminal blocks.
7. Check the separation of the power and safety extra-low voltage cables.
8. Check the connection of the underfloor heating safety thermostat (if used).
9. Check that traction arrester devices are used for all cables exiting the appliance.

#### 7.2.3 Checking the refrigeration circuit

---

1. Check the position of the outdoor unit, distance from the wall.
2. Check the tightness of the refrigerant connections.
3. Ensure that the evacuation pressure has been checked before filling.
4. Ensure that the evacuation time and the outdoor temperature have been checked during evacuation.

## 7.3 Commissioning procedure



### Caution

Initial commissioning must be performed by a qualified professional.

1. Refit all the panels, fascias and covers on the indoor unit and outdoor unit.
2. Arm the circuit breakers on the electric panel:
  - Outdoor unit circuit breaker
  - Indoor unit circuit breaker
  - Electrical back-up circuit breaker
3. Activate the on/off switch on the indoor unit.
  - ⇒ The heat pump is switched on. The **Welcome** message is displayed.

Fig.57

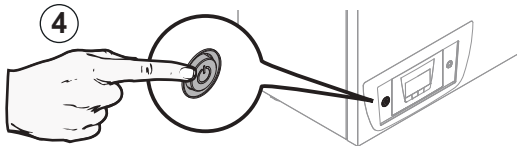

MW-1001278-1

Fig.58

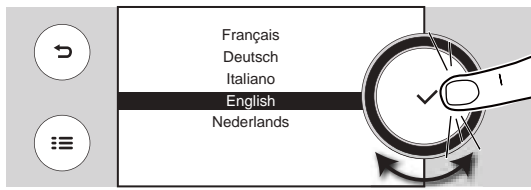

MW-6000659-3

4. Select the country and language.
5. Activate the **Daylight Saving Time** function.
6. Set the date and time.
7. Set the **CN1** and **CN2** parameters. The values are available on the data plate of the indoor unit. They are also shown in the table below. The **CN1** and **CN2** parameters are used to indicate to the system the type of outdoor unit and back-up present on the installation. They can be used to preconfigure the parameters based on the installation configuration.
8. Select **Confirm** to save the settings.
9. The heat pump begins its vent cycle.

### Points to check:

- After commissioning, domestic hot water production takes priority. Keep this operating mode to increase the temperature and check that the heat pump is operating correctly.
- At the end of the vent cycle, if the heat pump does not start, check the flow temperature on the user interface. The flow temperature must be above 10 °C to enable the outdoor unit to start. This protects the condenser during defrosting.  
If the flow temperature is below 10 °C, the back-ups start instead of the outdoor unit. The outdoor unit takes over when the flow temperature reaches 20 °C.

### 7.3.1 Configuration numbers CN1 et CN2

Configuration numbers allow the heat pump to be configured according to the type of back-up and the output of the outdoor unit installed.

Tab.44 With immersion heater; electrical back-up

Output of the outdoor unit	CN1	CN2
4.5 kW	1	2
6 kW	3	2
8 kW	5	2

## 7.4 Final instructions for commissioning

1. Check that the following installation components are switched on correctly:
  - Circulating pumps
  - Outdoor unit
  - Heating back-ups

2. Check the flow rate in the installation. It must be above the minimum threshold.
3. Check the setting of the thermostatic mixing valve (for domestic hot water production).
4. Shut down the heat pump and carry out the following operations:
  - After about 10 minutes, vent the air in the heating system.
  - Check the hydraulic pressure on the user interface. If necessary, top up the water level in the heating system.
  - Check the fouling level of the filter(s) present both in the heat pump and on the installation. If necessary, clean the filter(s).
5. Restart the heat pump.
6. Explain how the system works to the users.
7. Hand over all manuals to the user.

# 8 Operation

## 8.1 Use of the control panel

Fig.59

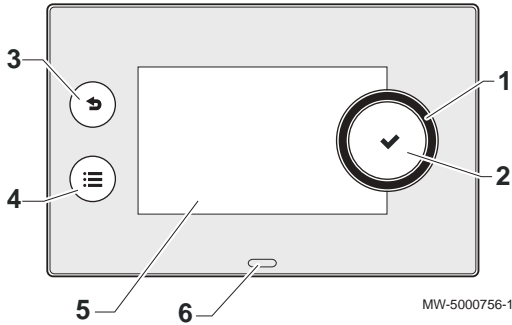

### 8.1.1 Description of the user interface

- 1 Rotary knob to select a menu or setting
- 2 Validation button ✓
- 3 Back key ← to return to the previous level or previous menu
- 4 Main menu key ≡
- 5 Display screen
- 6 LED for status indication:
  - continuous green = normal operation
  - flashing green = warning
  - continuous red = shutdown
  - flashing red = lockout

### 8.1.2 Description of the home screen

The home screen is displayed automatically after the appliance is started up.

The screen goes into standby if no key is pressed for five minutes. Press one of the buttons on the user interface to exit the standby screen and display the home screen.

Fig.60

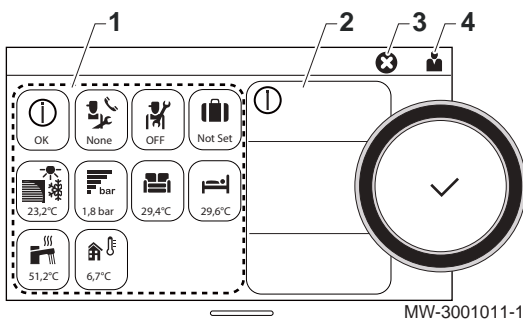



- 1 Access icons for menus and parameters  
The selected icon is highlighted.
- 2 Information on the selected icon
- 3 ⊗ error notification: only visible if an error occurs
- 4 Navigation level:
  - 👤: User level
  - 👷: Installer level.  
This level is reserved for installers and is protected by an access code. When this level is active, the icon becomes .

Tab.45 Icons on the home screen and information

Icon	Information	Description of the icon
	Error status	Information on operation of the appliance
	Maintenance status	Maintenance message
	Installer access	Installer Level
	Holiday programme	Holiday mode in all circuits simultaneously
	Air source heat pump	Heat pump flow temperature display
	Water pressure	Current water pressure display
	CIRCA/CIRCB	Symbol representing the operation zone Temperature display for zone A/B



Icon	Information	Description of the icon
	DHW tank	Temperature display for the domestic hot water
	Outdoor temperature	Outdoor temperature display

## 8.2 Starting and stopping the heat pump

### 8.2.1 Starting the heat pump

1. Switch on the outdoor unit and the indoor module.
2. Start up the heat pump by pressing the on/off switch.
3. Confirm the selection by pressing the settings button.
  - ⇒ The heat pump begins an automatic venting cycle that lasts around 3 minutes and is repeated each time the power is cut. If there is a problem, an error message is displayed on the home screen.
4. Check the hydraulic pressure in the installation indicated on the user interface.

⇒



#### Important

Recommended hydraulic pressure between 0.15 and 0.2 MPa (1.5 and 2.0 bar).

### 8.2.2 Shutting down the heat pump

The heat pump must be shut down in certain situations, for example during any intervention on the equipment. In other situations, such as an extended absence period, we recommend that the **Holiday** operating mode is used in order to benefit from the heat pump anti-blocking function and to protect the installation from frost.

To shut down the heat pump:



1. Switch off the indoor module by pressing the on/off switch.
2. Cut the power to the indoor module, outdoor unit and back-up circuit breakers.

## 9 Settings

### 9.1 Accessing the Installer level

Certain parameters, which may affect the operation of the appliance, are protected by an access code. Only the installer is authorised to modify these parameters.

To access the installer level:

1. Select the  icon.
2. Enter the code **0012**.
  - ⇒ The **Installer** level is activated . After modifying the desired settings, exit the **Installer** level.
3. To exit the Installer level, select the  icon, then **Confirm**.

If no actions are taken for 30 minutes, the system will automatically exit the Installer level.

### 9.2 Setting the parameters

#### 9.2.1 Setting the heating curve

The relationship between the outdoor temperature and the central heating flow temperature is controlled by a heating curve. This can be adjusted according to the requirements of the installation.

To set the heating curve for a zone:



1. Select the icon for the **zone** to be modified; , for example.
2. Select **Heating Curve**.
3. Set the following parameters:

Tab.46

Parameter	Description
<b>Slope:</b>	Value of the heating curve gradient. <ul style="list-style-type: none"> <li>• underfloor heating circuit: gradient between 0.4 and 0.7</li> <li>• radiator circuit: gradient of approx. 1.5</li> </ul>
<b>Max:</b>	Maximum temperature of the circuit
<b>Base:</b>	Curve base point temperature (default value: Off = automatic mode). If Base: Off, the curve base point temperature becomes equal to the room set point temperature
<b>50 °C; 0 °C</b>	Water temperature in the circuit for an outdoor temperature. This data is visible all along the curve.

Fig.61

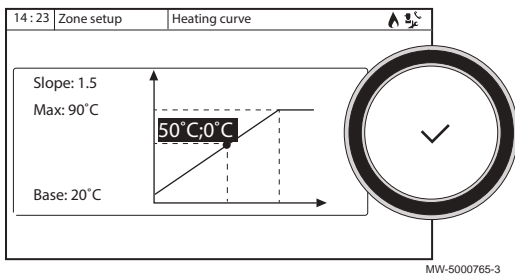

#### 9.2.2 Saving the installer details

The name and phone number of the installer can be saved so that the user can find it easily.



1. Press the  key.
2. Select **System Settings > Installer Details**.
3. Enter the name and phone number.

#### 9.2.3 Saving the commissioning settings

You can save all installation-specific settings. These settings can be restored if necessary, for example after replacement of the main electronic control system board.



1. Press the  key.
2. Select **Advanced Service Menu > Save as commissioning settings**.
3. Select **Confirm** to save the settings.

When you have saved the commissioning settings, the option **Revert commissioning settings** is available in the **Advanced Service Menu**.

#### 9.2.4 Resetting or re-establishing the parameters

##### ■ Configuring the type of outdoor unit and the type of back-up

The configuration numbers must be reset if the EHC-05 PCB is replaced or if there is a setting error.

To reset the configuration numbers:



1. Press the  key.
2. Select **Advanced Service Menu > Set Configuration Numbers > EHC-05**.
3. Set the **CN1** and **CN2** parameters. The values are available on the data plate of the indoor module.  
The **CN** parameters are used to indicate the type of outdoor unit present on the installation.
4. Select **Confirm** to save the settings.

##### ■ Auto-detecting options and accessories

Use this function after replacing a heat pump PCB in order to detect all the devices connected to the local CANbus.

To detect devices connected to the CAN bus:



1. Press the  key.
2. Select **Advanced Service Menu > Auto Detect**.
3. Select **Confirm** to carry out the auto-detect.

##### ■ Reverting to the commissioning settings

If the commissioning settings were saved, you can revert to the values specific to your installation.

To revert to the commissioning settings



1. Press the  key.
2. Select **Advanced Service Menu > Revert commissioning settings**.
3. Select **Confirm** to revert to the commissioning settings.

##### ■ Reverting to the factory settings

To revert to the factory settings for the heat pump:



1. Press the  key.
2. Select **Advanced Service Menu > Reset to Factory Settings**.
3. Select **Confirm** to revert to the factory settings.

#### 9.2.5 Improving heating comfort

The system does not allow the simultaneous production of heating and domestic hot water.

If the heating causes any kind of discomfort, the following settings can be adjusted to improve the comfort level:

- Modify the timer programming for domestic hot water production.  
Schedule domestic hot water production at night, for example.
- Modify the domestic water production setting parameters.



1. Adjust the following domestic hot water production setting parameters:

Tab.47

Access	Parameter	Description	Adjustment required
DHW tank > Parameters, counters, signals > Parameters	<b>Hysteresis DHW</b> (DP120)	Hysteresis temperature relative to the DHW temperature setpoint	Increase the set point temperature differential triggering the domestic hot water tank to be charged
	<b>Min. CH before DHW</b> (DP048)	Minimum heating duration between two periods of domestic hot water production	Increase the minimum heating duration between two domestic hot water production runs

2. If possible, set the production of domestic hot water for overnight periods using the timer programming for the domestic hot water tank.

### 9.2.6 Improving domestic hot water comfort

The system does not allow the simultaneous production of heating and domestic hot water.

If the domestic hot water causes any kind of discomfort, the following settings can be adjusted to improve the comfort level:

- Modify the timer programming for domestic hot water production. Schedule domestic hot water production based on your usage habits.
- Modify the domestic hot water production setting parameters. The consumption of electricity may rise.



1. Adjust the following domestic hot water production setting parameters:

Tab.48

Access	Parameter	Description	Adjustment required
DHW tank > Parameters, counters, signals > Parameters	<b>Hysteresis DHW</b> (DP120)	Hysteresis temperature relative to the DHW temperature setpoint	Reduce the set point temperature differential triggering the domestic hot water tank to be charged.
	<b>Min. CH before DHW</b> (DP048)	Minimum heating duration between two periods of domestic hot water production	Reduce the minimum heating duration between two domestic hot water production runs
	<b>Max. DHW duration</b> (DP047)	Maximum duration of the domestic hot water production	Increase the maximum authorised duration for domestic hot water production
	<b>DHW management</b> (DP051)	ECO mode: use of the heat pump only. Comfort mode: use of the heat pump and backup energy sources	Select Comfort (HP+Boiler) to systematically use the heat pump and the back-ups.

### 9.2.7 Drying screed with an outdoor unit connected

The screed drying function reduces the drying time of the screed for underfloor heating. This function must be activated for each zone.

Every day at midnight, the setpoint temperature is recalculated and the number of days is decreased.

For the screed drying times, follow the screed manufacturer's specifications.

Fig.62

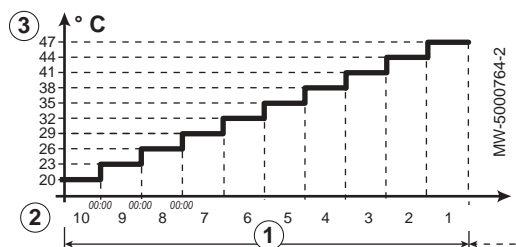

- ① Number of days of drying
- ② Drying start temperature
- ③ Drying end temperature



**Important**

If the return water temperature is below 10 °C, screed drying will start using the electrical back-up until the return water reaches a temperature of 20 °C (to prevent it taking too long, particularly in winter).

Tab.49 Example: to prepare the screed on which the floor covering will be applied, the parameters need to be adjusted every seven days

Day	① Number of days of drying	② Drying start temperature	③ Drying end temperature	Remarks
1 to 7	7	+25 °C	+55 °C or maximum authorised flow temperature	In increments of 5 K
8 to 14	7	+55 °C or maximum authorised flow temperature	+55 °C or maximum authorised flow temperature	No night reduction
15 to 21	7	+55 °C or maximum authorised flow temperature	+25 °C	In increments of 5 K



1. Set the parameters for the circuit with screed to be dried.

Tab.50

Access	Adjustment required	Parameter	Description
CIRCA0, CIRCA1, CIRCB1 or CIRCC1 > Set Screed Drying	① Number of days of drying	<b>Zone screed drying</b>	Setting of the screed drying program of the zone
	② Drying start temperature	<b>ScreedStartTemp</b>	Setting of the start temperature of the screed drying program of the zone
	③ Drying end temperature	<b>ScreedStopTemp</b>	Setting of the stop temperature of the screed drying program of the zone

The screed drying programme will start immediately and continue for the selected number of days.

At the end of the programme, the selected operating mode will restart.

### 9.2.8 Drying screed without the heat pump outdoor unit

Fig.63

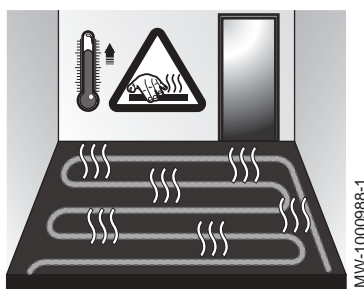

The indoor module can be used for drying screed using the electrical back-up. It is not necessary to connect the outdoor unit.

1. Switch on the indoor module and activate the screed drying function.
2. Adjust the parameters for screed drying.
  - ⇒ If the outdoor unit is not connected, the back-ups will start automatically.

### 9.2.9 Installing a buffer tank

A buffer tank is used to separate the heating circuits or to store energy. The buffer tank is used with one or two temperature sensors. The CIRCA0 circuit cannot be used at the same time as a buffer tank.

1. Connect the temperature sensor(s) for the buffer tank to the corresponding connectors:

Tab.51

Connection	Description
<p>Fig.64 One sensor</p> <p>MW-1001293-1</p>	<p>Buffer tank temperature sensor to the Tsyst1 connector on the SCB-10 PCB</p>
<p>Fig.65 Two sensors</p> <p>MW-1001295-1</p>	<ul style="list-style-type: none"> <li>• Buffer tank bottom temperature sensor to the Tsyst1 connector on the SCB-10 PCB</li> <li>• Buffer tank top temperature sensor to the Tsyst2 connector on the SCB-10 PCB</li> </ul>



2. Configure the pump for the **CIRCA0** zone as a system pump:

Tab.52

Access	Parameter	Adjustment required
<p>Air Src Heat pump &gt; Parameters, counters, signals &gt; Adv. Parameters</p>	Boiler Pump function (AP102)	No: all demands

3. Deactivate the CIRCA0 : circuit

Tab.53

Access	Parameter	Adjustment required
<p>CIRCA0</p>	Zone Function (CP020)	Disable

4. Activate the buffer tank function by selecting the number of sensors:

Tab.54

Access	Parameter	Adjustment required
<p>&gt; Installation Setup &gt; Buffer tank off</p>	Type Buffer Tank (BP001)	<p>Depending on the situation:</p> <ul style="list-style-type: none"> <li>• Disabled</li> <li>• One sensor</li> <li>• Two sensors</li> </ul>

5. Select the operating mode for the buffer tank.

Buffer tank operating mode	Adjustment required
Buffer tank used as a low-loss header.	By default, the buffer tank is managed as a low-loss header and does not require any specific settings. The temperature set point for the buffer tank is equal to the maximum set point temperature value taken from all the associated circuits. Example: with the temperature set points of CIRCA1: 22 °C, CIRCB1: 21 °C and CIRCC1: 20.5 °C, the buffer tank set point will be: (Maximum temperature for CIRCA1, CIRCB1, CIRCC1) = 22 °C.
Buffer tank used in storage mode	Configure the buffer tank load. See chapter: Configuring the buffer tank for storage, page 63

### 9.2.10 Configuring the buffer tank for storage

The buffer tank is used to store energy either via the buffer tank timer programme or by a contact connected to the TEL digital input. The buffer tank must be installed and configured with one or two temperature sensors.



1. Program the load timers for the buffer tank.

Tab.55

Access	Adjustment required
> Installation Setup > Buffer tank > Buffer Tank Schedule	Program the <b>Operating</b> activity which will activate the buffer tank load.

Fig.66

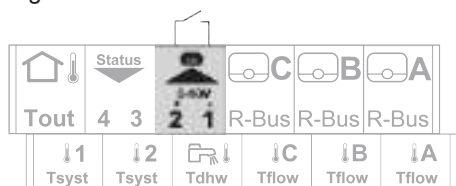

MW-1001294-1

## SCB-10

2. If necessary, configure and program the TEL digital input.

Tab.56

Access	Parameter	Description	Adjustment required
> Installation Setup > Digital input > Parameters	Digital input config (EP046)	Sets the general configuration of the digital input	Buffer Tank input
	Logic level Digi In (EP056)	Sets the logic level contact of the Smart Control Board digital input	<ul style="list-style-type: none"> <li>Open: Buffer tank load when the contact is opened.</li> <li>Closed: Buffer tank load when the contact is closed.</li> </ul>

3. Select the set point temperature control mode for the buffer tank load:

Tab.57

Access	Parameter	Description	Adjustment required
> Installation Setup > Buffer tank	Buff Tank HC Strat. (BP002)	Heating Cooling Control strategy used with buffer tank	<ul style="list-style-type: none"> <li>Fixed setpoint</li> <li>Calculated setpoint</li> <li>Dedicated slope</li> </ul>

Tab.58 Buff Tank HC Strat. (BP002)

Adjustment required	Description
<ul style="list-style-type: none"> <li>Fixed setpoint</li> </ul>	The buffer tank set point temperature is equal to the value for the parameter <b>Stp Buffertank Heat</b> (BP003) or <b>Setp Buffertank Cool</b> (BP004). Example: 55 °C
<ul style="list-style-type: none"> <li>Calculated setpoint</li> </ul>	The buffer tank set point temperature is equal to the highest set point for the connected heating circuits with the overheating temperature set by the parameter <b>BufferTankTcalOffset</b> (BP013). Example: with CIRCA1: 22 °C, CIRCB1: 21 °C, the buffer tank setpoint will be: 22 °C + 10 °C = 32 °C
<ul style="list-style-type: none"> <li>Dedicated slope</li> </ul>	The buffer tank set point temperature depends on the outdoor temperature, the parameters <b>Stp Buffertank Heat</b> (BP003) and <b>Buffer Tank Slope</b> (BP005) and the following formula: Buffer tank set point = (- outdoor temperature) x <b>Buffer Tank Slope</b> + <b>Stp Buffertank Heat</b> Example: (- -5 °C ) x 1.5 + 55 °C = 62.5 °C

Tab.59 Buffer tank management with one sensor

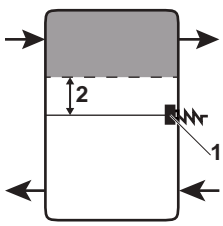
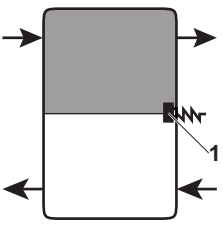
Buffer tank status	Description
Fig.67 Buffer tank in demand 	The buffer tank is in load demand when the temperature measured by the sensor is less than the difference between the buffer tank temperature set point and the temperature hysteresis. <ol style="list-style-type: none"> <li>Sensor temperature = buffer tank set point temperature - <b>BufferTank HystStart</b> (BP014): Hysteresis of temperature which determines the start of Buffer Tank storage</li> <li><b>BufferTank HystStart</b> (BP014) : Hysteresis of temperature which determines the start of Buffer Tank storage</li> </ol>
Fig.68 Buffer tank loaded 	The buffer tank is loaded when the temperature measured by the sensor is equal to the buffer tank temperature set point. <ol style="list-style-type: none"> <li>Sensor temperature = buffer tank set point temperature + <b>BufferTank HystStop</b> (BP019): Hysteresis of temperature which determines the start of Buffer Tank storage</li> </ol>

Tab.60 Buffer tank management with two sensors (optional)

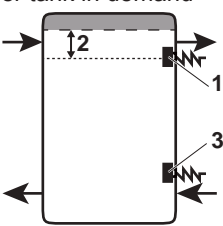
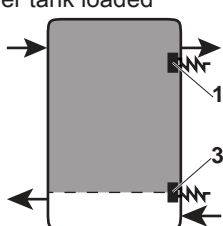
Buffer tank status	Description
Fig.69 Buffer tank in demand 	The buffer tank is in load demand when the temperature measured by the top sensor is less than the difference: temperature set point - temperature hysteresis. <ol style="list-style-type: none"> <li>Buffer tank top sensor temperature = buffer tank set point temperature - <b>BufferTank HystStart</b> (BP014): Hysteresis of temperature which determines the start of Buffer Tank storage</li> <li><b>BufferTank HystStart</b> (BP014): Hysteresis of temperature which determines the start of Buffer Tank storage )</li> <li>Temperature of the buffer tank bottom sensor</li> </ol>
Fig.70 Buffer tank loaded 	The buffer tank is loaded when the temperature measured by the bottom sensor is equal to the buffer tank temperature set point. <ol style="list-style-type: none"> <li>Temperature of the buffer tank top temperature sensor</li> <li>Temperature of the buffer tank bottom sensor = buffer tank set point temperature + <b>BufferTank HystStop</b> (BP019): Hysteresis of temperature which determines the start of Buffer Tank storage</li> </ol>



4. Configure the temperature set point parameters for the buffer tank load:

Tab.61 Parameters to configure

Access	Parameter	Description	Default value
 > Installation Setup > Buffer tank > Parameters	<b>Stp Buffertank Heat</b> (BP003)	Temperature setpoint for buffer tank in heating mode From 5 °C to 100 °C	70 °C
	<b>Setp Buffertank Cool</b> (BP004)	Temperature setpoint for Buffer tank in cooling mode From 5 °C to 25 °C	18 °C
	<b>Buffer Tank Slope</b> (BP005)	Buffer Tank Slope From 0 to 4	1.5
	<b>BufferTankTcalOffset</b> (BP013)	Offset to add to the calculate Setpoint of the Buffer Tank From 0 °C to 20 °C	5 °C
	<b>BufferTank HystStart</b> (BP014)	Hysteresis of temperature which determines the start of Buffer Tank storage From 1 °C to 20 °C	6 °C
	<b>BufferTank HystStop</b> (BP019)	Hysteresis of temperature which determines the stop of buffer tank storage From -30 °C to +30 °C	0 °C Do not change the value

5. Configure the back-ups so that they will start when the buffer tank set point is greater than 60 °C:

Tab.62

Access	Parameter	Description	Adjustment required
 23.5 Air Src Heat pump > Parameters, counters, signals > Parameters	<b>Bivalent temperature</b> (HP000)	Bivalent temperature: Above the bivalent temperature, the backup energy source is not allowed to operate	5 °C

6. Configure the parameter **Max CH flow setpoint** (AP063):

Tab.63

Access	Parameter	Description	Adjustment required
 23.5 Air Src Heat pump > Parameters, counters, signals > Adv. Parameters	<b>Max CH flow setpoint</b> (AP063)	Maximum central heating flow temperature setpoint	Enter a temperature higher than the buffer tank set point, otherwise the buffer tank temperature will be limited by this parameter.

### 9.2.11 Configuring and using the CB04 auto-filling option kit

The CB04 auto-filling option kit is used to fill the heating circuits or to maintain the optimal pressure in the heating circuits, without human intervention. After having followed the instructions for assembly of the option kit, simply configure a few parameters to automatically obtain or maintain an optimal pressure. The heat pump does not start up during the auto-filling phase.



1. Activating the auto-filling function:

Tab.64

Access	Parameter	Adjustment required
 > Installation Setup > Heating circuit autofill > Settings	<b>Auto Filling</b> (AP014)	Auto

2. If necessary, start filling the installation:

Tab.65

Access	Parameter
 > Installation Setup > Heating circuit autofill >	<b>Start water filling:</b> Select this parameter to start filling the installation. The parameter <b>Filling Inst Timeout</b> (AP023) defines the maximum duration authorised to obtain a pressure of 0.3 bar during the first water fill with the auto-filling kit. It is 60 minutes.

⇒ If there is an error on the user interface, restart the auto-filling function as many times as needed.

3. Configuring the auto-filling function:

Tab.66

Access	Parameter	Description	Default value
 > Installation Setup > Heating circuit autofill > Settings	<b>Min. water pressure</b> (AP006)	Appliance will report low water pressure below this value From 0 bar to 6 bar	0.3 bar
	<b>Filling Inst Timeout</b> (AP023)	Maximum duration authorised to obtain a pressure of 0.3 bar during the first water fill with the auto-filling kit. From 0 Min to 60 Min	60 minutes
	<b>Filling Interval</b> (AP051)	The minimum time that is allowed between two top-up fillings. From 0 to 65535 days	90 days
	<b>Top up timeout</b> (AP069)	Maximum time to top up the water in the circuit during operation. 0 Min to 65535 Min	5 minutes
	<b>Operational Pressure</b> (AP070)	The operational water pressure the device should be working on. From 0 bar to 2.5 bar	2 bar
	<b>InstallMaxTimeOut</b> (AP071)	Maximum time that is needed to fill the complete installation. From 0 Sec to 3600 Sec	3600 seconds

## 9.2.12 Supplying the heat pump with photovoltaic energy

When lower cost electrical energy is available, such as photovoltaic energy, the heating circuit and domestic hot water tank (if present) can be overheated. Underfloor cooling cannot be supplied with power in this way.

1. Cut off the mains electricity to the indoor unit.
2. Connect a dry contact to the **BL1** or **BL2 IN** multifunction input.
3. Switch the indoor unit back on.
4. Configure the heat pump parameters



Tab.67 Input parameters

Access	Parameter	Description	Adjustment required
 23.5 Air Src Heat pump > Parameters, counters, signals > Parameters	<b>BL function</b> (AP001)	BL input function selection	<ul style="list-style-type: none"> <li>• Photovoltaic HP Only or</li> <li>• PV HP And backup</li> </ul>
	<b>BL2 function</b> (AP100)	BL2 input function selection	<ul style="list-style-type: none"> <li>• Photovoltaic HP Only or</li> <li>• PV HP And backup</li> </ul>



5. In order to voluntarily overheat the installation and benefit from low-tariff electricity, set the set point temperatures that can be exceeded.

Tab.68 Voluntary overheating parameters

Access	Parameter	Description	Adjustment required
23.5 <b>Air Src Heat pump &gt; Parameters, counters, signals &gt; Parameters &gt; Adv. Parameters</b>	<b>Offset heating - PV</b> (HP091)	Heating setpoint temperature offset when photovoltaic energy is available	Set the authorisation to exceed the heating set point temperature from 0 to 30 °C
	<b>Offset DHW - PV</b> (HP092)	Domestic hot water setpoint temperature offset when photovoltaic energy is available	Set the authorisation to exceed the domestic hot water set point temperature from 0 to 30 °C

### 9.2.13 Reducing the noise level of the outdoor unit

- Silent mode is used to reduce the noise level on the outdoor unit during programmed hours, particularly at night. This mode gives temporary precedence to silent running rather than temperature control.
- This package is not compatible with the AWHP 4.5 MR outdoor unit.
  1. Connect the silent running kit to the outdoor unit.
  2. Connect the silent running kit to one of the CIRCA1, CIRCB1, CIRCC1 or CIRCAUX1 zone pump outlets of the SCB-10 PCB.
  3. Set the timer programming for this zone: silent mode corresponds to the Sleep activity.

## 9.3 Menu tree



Tab.69

Menus accessible using the  button
Installation Setup
Commissioning Menu
Advanced Service Menu
Error History
System Settings
Version Information

## 9.4 List of parameters

The appliance parameters are described directly in the user interface. Some of these parameters are listed in the following chapters with additional information and their default values.

### 9.4.1 Installation Setup > CIRCA0 > Parameters, counters, signals

The **CIRCA0** circuit is on the EHC-05 PCB.

CP : Circuits Parameters = Heating circuit parameters

Tab.70 Parameters menu

Parameter	Description	Factory setting
MaxZoneTFlowSetpoint (CP000)	Maximum Flow Temperature setpoint zone <b>CIRCA0</b> : can be set from 7 °C to 75 °C	Electrical back-up: 75
Zone Function (CP020)	Type of CIRCA0 connected to the <b>EHC-05</b> PCB: <ul style="list-style-type: none"> <li>• Disable = heating circuit deactivated</li> <li>• Direct = radiators. Cooling not possible.</li> <li>• Mixing Circuit = underfloor heating. Cooling possible.</li> <li>• Swimming pool = not available</li> <li>• High Temperature = not used</li> <li>• Fan Convectector = convection fan. Cooling possible.</li> </ul>	Direct
MaxReducedRoomT.Lim (CP070)	Max Room Temperature limit of the circuit in reduced mode, that allows switching to comfort mode Can be set from 5 °C to 30 °C	16
Zone HCZP Comfort (CP210)	Comfort footpoint of the temperature of heat curve of the circuit <ul style="list-style-type: none"> <li>• can be set from 16 to 90 °C</li> <li>• set to 15 = the curve base temperature is set automatically and is the same as the room set point temperature</li> </ul>	15
Zone HCZP Reduced (CP220)	Reduced footpoint of the temperature of heat curve of the circuit <ul style="list-style-type: none"> <li>• can be set from 6 to 90 °C</li> <li>• set to 15 = the curve base temperature is set automatically and is the same as the room set point temperature</li> </ul>	15
Zone Heating Curve (CP230)	Heating curve temperature gradient of the zone Can be set from 0 to 4	1.5
ZoneRoomUnitInfl (CP240)	Adjustment of the influence of the zone room unit Can be set from 0 to 10	3
TypeReducedNightMode (CP340) Parameter linked to the CP070 parameter	Type of reduced night mode, stop or maintain heating of circuit <ul style="list-style-type: none"> <li>• Stop heat demand: heating is deactivated when the room set point temperature set in the timer programme is below the threshold set in CP070.</li> <li>• Continue heat demand: the heating set point is maintained independently of the threshold set in CP070.</li> </ul>	Stop heat demand
Control strategy (CP780)	Selection of the control strategy for the zone <ul style="list-style-type: none"> <li>• Automatic</li> <li>• Room Temp. based</li> <li>• Outdoor Temp. based</li> <li>• Outdoor &amp; room based</li> </ul>	Automatic

#### 9.4.2 Installation Setup > Stratified DHW tank > Parameters, counters, signals

A domestic hot water sensor must be connected to the EHC-05 PCB to display these parameters. The **Stratified DHW tank** circuit is on the **EHC-05** PCB.

Tab.71 Parameters menu

Parameter	Description	Factory setting
DhwMaxTemp (DP046)	Max. flow temperature for domestic hot water production. Can be set from 10 to 70 °C	70 °C
Max. DHW duration (DP047)	Maximum authorised duration for domestic hot water production. Can be set from 1 to 10 hours	3 hours
Min. CH before DHW (DP048)	Minimum heating duration between two domestic hot water production runs. Can be set from 0 to 10 hours	2 hours

Parameter	Description	Factory setting
DHW management (DP051)	ECO mode: use of the heat pump only. Comfort mode: use of the heat pump and backup energy sources: <ul style="list-style-type: none"> <li>• ECO (Only HP): use of the heat pump only</li> <li>• Comfort (HP+Boiler): use of the heat pump and back-ups</li> </ul>	ECO (Only HP)
Hysteresis DHW (DP120)	Hysteresis temperature relative to the DHW temperature setpoint Can be set from 0 °C to 40 °C	15

Tab.72 Adv. Parameters menu

Parameter	Description	Factory setting
Delay StartBackupDHW (DP090)	Electrical back-up start-up time delay for domestic hot water. Can be set from 0 to 120 min	90 min
Delay stop BackupDHW (DP100)	Electrical back-up shutdown time delay for domestic hot water. Can be set from 0 to 120 min	2 min
Delay BackupStageDHW (DP110)	Electrical back-up second stage start-up time delay for domestic hot water. Can be set from 0 to 255 min	5 min
DHW backup type (DP334)	Backup type used for domestic hot water production: <ul style="list-style-type: none"> <li>• Indoor Unit: indoor unit electrical back-ups</li> <li>• DHW Tank : DHW tank electrical back-ups</li> <li>• IDU/DhwTank Cooling: Indoor unit electrical back-ups in winter/DHW tank electrical back-ups in cooling mode</li> </ul>	Indoor Unit

#### 9.4.3 Installation Setup > CIRCA1/CIRCB1/DHW1/CIRCC1/CIRCAUX1 > Parameters, counters, signals >

Depending on the installation configuration, only certain circuits are available. The **CIRCA1 \ CIRCB1 \ DHW1 \ CIRCC1 \ CIRCAUX1** circuits are on the **SCB-10** PCB.

Tab.73 Correspondence between the parameters and the circuits

<ul style="list-style-type: none"> <li>• <b>CPxx0</b> parameters ending in <b>0</b> correspond to the <b>CIRCA1</b> circuit</li> <li>• <b>CPxx1</b> parameters ending in <b>1</b> correspond to the <b>CIRCB1</b> circuit</li> <li>• <b>CPxx2</b> parameters ending in <b>2</b> correspond to the <b>DHW1</b> circuit</li> <li>• <b>CPxx3</b> parameters ending in <b>3</b> correspond to the <b>CIRCC1</b> circuit</li> <li>• <b>CPxx4</b> parameters ending in <b>4</b> correspond to the <b>CIRCAUX1</b> circuit</li> </ul>
--

Tab.74 Parameters menu

Parameter	Factory setting for each circuit	Description
MaxZoneTFlowSetpoint (CP000 CP001 CP002 CP003 CP004)	<b>CIRCA1:</b> Electrical back-up: 50 <b>CIRCB1:</b> Electrical back-up: 50 <b>DHW1:</b> Electrical back-up: 95 <b>CIRCC1:</b> Electrical back-up: 50 <b>CIRCAUX1:</b> Electrical back-up: 95	Maximum Flow Temperature setpoint zone For circuit A: Can be set from 7 °C to 100 °C
Zone Function (CP020 CP021 CP022 CP023 CP024)	<b>CIRCA1:</b> Direct <b>CIRCB1:</b> Disable <b>DHW1:</b> Disable <b>CIRCC1:</b> Disable <b>CIRCAUX1:</b> Disable	Functionality of the zone <ul style="list-style-type: none"> <li>• Disable</li> <li>• Direct</li> <li>• Mixing Circuit</li> <li>• Swimming pool</li> <li>• High Temperature</li> <li>• Fan Convector</li> <li>• DHW tank</li> <li>• Electrical DHW</li> <li>• Time Program</li> <li>• ProcessHeat</li> <li>• DHW Layered</li> <li>• DHW Internal tank</li> <li>• DHW Commercial Tank</li> <li>• DHW FWS EXT</li> </ul>
Zone HCZP Comfort (CP210 CP211 CP212 CP213 CP214)	<b>CIRCA1:</b> 15 <b>CIRCB1:</b> 15 <b>DHW1:</b> 15 <b>CIRCC1:</b> 15 <b>CIRCAUX1:</b> 15	Comfort footpoint of the temperature of heat curve of the circuit <ul style="list-style-type: none"> <li>• Can be set from 15 °C to 90 °C</li> <li>• set to 15 = the curve base temperature is set automatically and is the same as the room set point temperature</li> </ul>
Zone HCZP Reduced (CP220 CP221 CP222 CP223 CP224)	<b>CIRCA1:</b> 15 <b>CIRCB1:</b> 15 <b>DHW1:</b> 15 <b>CIRCC1:</b> 15 <b>CIRCAUX1:</b> 15	Reduced footpoint of the temperature of heat curve of the circuit <ul style="list-style-type: none"> <li>• can be set from 6 to 90 °C</li> <li>• set to 15 = the curve base temperature is set automatically and is the same as the room set point temperature</li> </ul>
TypeReducedNightMode (CP340 CP341 CP342 CP343 CP344)	<b>CIRCA1:</b> Stop heat demand <b>CIRCB1:</b> Stop heat demand <b>DHW1:</b> Stop heat demand <b>CIRCC1:</b> Stop heat demand <b>CIRCAUX1:</b> Stop heat demand	Type of reduced night mode, stop or maintain heating of circuit <ul style="list-style-type: none"> <li>• Stop heat demand</li> <li>• Continue heat demand</li> </ul>
Control strategy (CP780 CP781 CP782 CP783 CP784)	<b>CIRCA1:</b> Automatic <b>CIRCB1:</b> Automatic <b>DHW1:</b> not used <b>CIRCC1:</b> Automatic <b>CIRCAUX1:</b> Automatic	Selection of the control strategy for the zone <ul style="list-style-type: none"> <li>• Automatic</li> <li>• Room Temp. based</li> <li>• Outdoor Temp. based</li> <li>• Outdoor &amp; room based</li> </ul>

Tab.75 Adv. Parameters menu

Parameter	Factory setting for each circuit	Description
ConfigZonePump Out (CP290 CP291 CP292 CP293 CP294 )	CIRCA1: Zone output CIRCB1: Zone output DHW1: DHW mode CIRCC1: Zone output CIRCAUX1: DHW looping	Configuration of Zone Pump Output <ul style="list-style-type: none"> <li>• Zone output</li> <li>• CH mode</li> <li>• DHW mode</li> <li>• Cooling mode</li> <li>• Error report</li> <li>• Burning</li> <li>• Service flag</li> <li>• System error</li> <li>• DHW looping</li> <li>• Primary pump</li> <li>• Buffer pump</li> </ul>
Zone Buffered (CP770 CP771 CP772 CP773 CP774 )	CIRCA1: Yes CIRCB1: Yes DHW1: Yes CIRCC1: Yes CIRCAUX1: Yes	The zone is after a Buffer tank <ul style="list-style-type: none"> <li>• No</li> <li>• Yes</li> </ul>

#### 9.4.4 Installation Setup > Air Src heat pump > Parameters, counters, signals

HP : Heat-pump Parameters = Heat pump parameters

AP : Appliance Parameters = Appliance advanced parameters

Tab.76 Parameters menu

Parameter	Description	Factory setting
Bivalent temperature (HP000)	Above the bivalent temperature, the backup energy source is not allowed to operate Can be set from -10 °C to 20 °C	5
Delay StartBackup CH (HP030)	Start-up time delay for back-ups in central heating mode Can be set from 0 Min 600 Min	0
Delay stop backup CH (HP031)	Shutdown time delay for back-ups in central heating mode Can be set from 0 Min to 600 Min	4
Delay Min.Outdoor T. (HP047)	Start-up time delay for back-ups corresponding to the minimum outdoor temperature HP049. The dynamic time delay is activated when HP030=0 Can be set from 0 Min to 60 Min	8
Delay Max.Outdoor T (HP048)	Start-up time delay for back-ups corresponding to the maximum outdoor temperature HP050. The dynamic time delay is activated when HP030 = 0 Can be set from 0 Min 60 Min	30
Min.Outdoor T.backup (HP049)	Minimum outdoor temperature used to set HP047. Can be set from -30 °C to 0 °C	-10
Max.Outdoor T.backup (HP050)	Maximum outdoor temperature used to set HP048. Can be set from -30 °C to 20 °C	15
Min. Outdoor T. HP (HP051)	Minimum outdoor temperature authorising heat pump operation. Can be set from -20 °C to 5 °C	-20
Delay BackupStage CH (HP108)	Time delay for activating the second electrical back-up stage in central heating mode Can be set from 1 Min to 255 Min	4
Min. water pressure (AP006)	Appliance will report low water pressure below this value Can be set from 0 bar to 6 bar	0.3
MessMinWaterPress ure (AP058)	Warning message indicating that pressure is low Can be set from 0 bar to 2 bar	0.8

Tab.77 Adv. Parameters menu

Parameter	Description of the advanced parameters	EHC-05 factory setting
Max. HP Flow T. (HP002)	Maximum flow temperature of the heat pump without backup energy sources. Can be set from 20 °C to 65 °C	65
Min. HP Cooling T. (HP003)	Minimum flow temperature of the heat pump in cooling mode Can be set from 5 °C to 30 °C	5
Minimum flow rate (HP010)	Minimum flow rate. Can be set from 0 l/min to 90 l/min	5 for 4.5 kW 5 for 6 kW 8 for 8 kW
Flow rate warning (HP011)	Flow rate that triggers a warning message indicating that flow rate becomes insufficient Can be set from 0 l/min to 95 l/min	7 for 4.5 kW 7 for 6 kW 9 for 8 kW
Backup type (HP029)	Type of backup used in the heat pump: <ul style="list-style-type: none"> <li>• 0 =No Backup</li> <li>• 1 =1 Electrical Stage</li> <li>• 2 =2 Electrical Stages</li> <li>• 3 =Boiler Backup</li> </ul>	2
Elec. Pulse value (HP033)	Value of the pulse coming from the electrical counter. Can be set from 0 Wh to 1000 Wh	1
Backup 1 capacity (HP034)	Declaration of the capacity of the 1st stage of the electrical backup used for the energy counter. Can be set from 0 kW to 10 kW	0
Backup 2 capacity (HP035)	Declaration of the capacity of the 2nd stage of the electrical backup used for the energy counter. Can be set from 0 kW to 10 kW	0
COP Threshold (HP054)	COP threshold above which the heat pump is authorised to operate.	2.5
Hybrid mode (HP061)	Not used	0
Boiler efficiency (HP068)	Not used	100
Cool.Setpoint offset (HP079)	Maximum offset applied to the cooling setpoint when a 0-10V humidity sensor is used Can be set from 0 °C to 15 °C	5
Humidity level (HP080)	Relative humidity level over which the offset is added to the cooling setpoint Can be set from 0 % to 100 %	70
Setpoint Hyst. Low (HP089)	Heat pump trip differential in relation to the set point temperature. Can be set from 0 to 10°C	4 °C
Offset heating - PV (HP091)	Heating setpoint temperature offset when photovoltaic energy is available Can be set from 0 °C to 30 °C	0
Offset DHW - PV (HP092)	Domestic hot water setpoint temperature offset when photovoltaic energy is available Can be set from 0 °C to 30 °C	0
kW rating DHW backup (HP145)	Power supply for the domestic hot water tank electrical back-up. Can be set from 0 to 10 kW	0
BL function (AP001)	BL input function selection BL1: <ul style="list-style-type: none"> <li>• 1 = Full blocking of the installation – frost protection not guaranteed</li> <li>• 2 = Partial blocking of the installation – installation frost protection</li> <li>• 3 = User reset locking</li> <li>• 4 = Backup relieved</li> <li>• 5 = Generator relieved</li> <li>• 6 =Gen.&amp;Backup relieved</li> <li>• 7 =High, Low Tariff</li> <li>• 8 =Photovoltaic HP Only</li> <li>• 9 = PV HP And backup</li> <li>• 10 = Smart Grid ready</li> <li>• 11 = Heating Cooling</li> </ul>	2



Parameter	Description of the advanced parameters	EHC-05 factory setting
Manual Heat Demand (AP002)	Enable manual heat demand function. In this mode, the temperature set point used will be that for the AP026.	0
Setpoint manual HD (AP026)	Flow temperature setpoint for manual heat demand. Can be set from 7 to 70 °C Set point used when manual mode is active (AP002 = 1)	40
Cooling mode (AP028)	Configuration of the cooling mode <ul style="list-style-type: none"> <li>• 0 = Off</li> <li>• 1 = Active cooling on</li> </ul>	0
Max CH flow setpoint (AP063)	Maximum central heating flow temperature setpoint. Can be set from 20 °C to 75 °C	Electrical back-up: 75
Humidity sensor (AP072)	Humidity sensor configuration: <ul style="list-style-type: none"> <li>• 0 =No</li> <li>• 1 =OnOff</li> <li>• 2 =0-10V sensor</li> </ul>	0
BL1 contact config. (AP098)	BL1 input contact configuration: <ul style="list-style-type: none"> <li>• 0 = input active on Open contact</li> <li>• 1 = input active on Closed contact</li> </ul>	0
BL2 contact config. (AP099)	BL2 input contact configuration: <ul style="list-style-type: none"> <li>• 0 = input active on Open contact</li> <li>• 1 = input active on Closed contact</li> </ul>	0
BL2 function (AP100)	BL2 input function selection <ul style="list-style-type: none"> <li>• 1 = Full blocking of the installation – frost protection not guaranteed</li> <li>• 2 = Partial blocking of the installation – installation frost protection</li> <li>• 3 = User reset locking</li> <li>• 4 = Backup relieved</li> <li>• 5 = Generator relieved</li> <li>• 6 =Gen.&amp;Backup relieved</li> <li>• 7 =High, Low Tariff</li> <li>• 8 =Photovoltaic HP Only</li> <li>• 9 = PV HP And backup</li> <li>• 10 = Smart Grid ready</li> <li>• 11 = Not used</li> </ul>	2
De-aeration cycle (AP101)	De-air cycle settings: <ul style="list-style-type: none"> <li>• 0 =No deair at power up</li> <li>• 1 =Always deair at pwr</li> </ul>	1

#### 9.4.5 Installation Setup > Cascade management B > Parameters, counters, signals

NP : Network Parameters = Cascade parameters

Tab.78 Parameters

Parameter	Description	Factory setting SCB-10
Cascade Permutation (NP005)	Choice of the leading generator, .AUTO: Switching of order every 7 days Can be set from 0 to 127	0
Cascade Type (NP006)	Cascading boilers by adding successively or in parallel, the boilers function simultaneously <ul style="list-style-type: none"> <li>• 0: Traditional</li> <li>• 1: parallel</li> </ul>	0
CascTOutsideHeat Parl (NP007)	Outdoor start temperature heating of all stages in parallel mode Can be set from -10 °C to 20 °C	10
CascTPostRunGen ePump (NP008)	Duration of post operation of the cascade generator pump Can be set from 0 Min to 30 Min	4

Parameter	Description	Factory setting SCB-10
CascInterStageTime (NP009)	Switch on and switch off timing for the producer of the cascade Can be set from 1 Min to 60 Min	4
CascTOutsideCoolPara (NP010)	Outdoor start temperature cooling of all stages in parallel mode Can be set from 10 °C to 40 °C	30
CascadeTypeAlgo (NP011)	Choice of Cascade Algorithm type, power or temperature <ul style="list-style-type: none"> <li>• Temperature</li> <li>• Power</li> </ul>	Temperature
CascPowerRiseTime (NP012)	Cascade, Time to reach Temperature Setpoint Can be set from 1 to 10	1
CascForceStopPprim (NP013)	Force Primary Pump to Stop on cascade <ul style="list-style-type: none"> <li>• No</li> <li>• Yes</li> </ul>	No
Cascade Mode (NP014)	Functionnement Mode of cascade : automatic, heating or cooling <ul style="list-style-type: none"> <li>• Automatic</li> <li>• Heating</li> <li>• Cooling</li> </ul>	Automatic

Tab.79 Adv. Parameters

ADV parameter	Description of the ADV advanced parameters	Factory setting SCB-10
NP001	Hysteresis high for Producer Manager Can be set from 0.5 °C to 10 °C	3
NP002	Hysteresis low for Producer Manager Can be set from 0.5 °C to 10 °C	3
NP003	Maximum error gain for Producer Manager Can be set from 0 °C to 10 °C	10
NP004	Proportional Factor for cascade with Temperature algorithm Can be set from 0 to 10	1

#### 9.4.6 Installation Setup > Outside temp > Parameters, counters, signals

---

Tab.80 Parameters

Parameter	Description	Factory setting SCB-10
Outdoor sensor (AP056)	Enable outdoor sensor <ul style="list-style-type: none"> <li>• No outside sensor</li> <li>• AF60</li> <li>• QAC34</li> </ul>	1
Summer Winter (AP073)	Outdoor temperature: upper limit for heating Can be set from 15 °C to 30.5 °C	22
Season cross-over (AP075)	Temperature variance from set outdoor upper temp. limit in which the generator will not heat or cool Can be set from 0 to 10 °C	4

#### 9.4.7 Installation Setup > Digital input > Parameters, counters, signals

---

EP : Entry Parameters = Input parameters

Tab.81 Parameters

Parameter	Description	Factory setting SCB-10
Digital input config (EP046)	Sets the general configuration of the digital input <ul style="list-style-type: none"> <li>• Stop heating + DHW</li> <li>• Stop heating</li> <li>• Stop DHW</li> <li>• Forced setpoint</li> <li>• Buffer Tank input</li> </ul>	Stop heating + DHW
Logic level Digi In (EP056)	Sets the logic level contact of the Smart Control Board digital input <ul style="list-style-type: none"> <li>• Open</li> <li>• Closed</li> <li>• Off</li> </ul>	Closed
Req FlowSetp digi In (EP066)	Requested flow setpoint when digital input is configured to forced heat Can be set from 7 °C to 100 °C	80

#### 9.4.8 Installation Setup > Analogue input > Parameters, counters, signals

EP : Entry Parameters = Input parameters

Tab.82 Adv. Parameters

ADV parameter	Description of the ADV advanced parameters	Factory setting SCB-10
Sensor input config (EP036)	Sets the general configuration of the sensor input Tsyst1 <ul style="list-style-type: none"> <li>• Disabled</li> <li>• DHW tank</li> <li>• DHW tank top</li> <li>• Buffer tank sensor</li> <li>• Buffer Tank top</li> <li>• System (cascade)</li> </ul>	Disabled
Sensor input config (EP037)	Sets the general configuration of the sensor input Tsyst2 <ul style="list-style-type: none"> <li>• Disabled</li> <li>• DHW tank</li> <li>• DHW tank top</li> <li>• Buffer tank sensor</li> <li>• Buffer Tank top</li> <li>• System (cascade)</li> </ul>	Disabled

#### 9.4.9 Installation Setup > 0-10 V input > Parameters, counters, signals

Tab.83 EP : Entry Parameters = Input parameters

Parameter	Description	Factory setting SCB-10
SCB func. 10V PWMin (EP014)	Smart Control Board function 10 Volt PWM input <ul style="list-style-type: none"> <li>• Off</li> <li>• Temperature control</li> <li>• Power control</li> </ul>	Off
Max Setp Temp 0-10V (EP030)	Sets the minimum set point temperature for 0 - 10 volts for the Smart Control Board Can be set from 0 °C to 100 °C	0
Min Setp Power 0-10V (EP031)	Sets the maximum set point temperature for 0 - 10 volts for the Smart Control Board Can be set from 0.5 °C to 100 °C	100

Parameter	Description	Factory setting SCB-10
Min Setp Volt 0-10V (EP034)	Minimum voltage for 0-10 V input corresponding to the minimum set point Can be set from 0 V to 10 V	0.5
Max Setp Volt 0-10V (EP035)	Maximum voltage for 0-10 V input corresponding to the maximum set point Can be set from 0 V to 10 V	10

**9.4.10 Installation Setup > Appliance status > Parameters, counters, signals**

EP : Entry Parameters = Input parameters

Tab.84 Parameters

Parameter	Description	Factory setting SCB-10
Status relay func. (EP018)	Status relay function <ul style="list-style-type: none"> <li>• No Action</li> <li>• Alarm</li> <li>• Alarm Inverted</li> <li>• Compressor on</li> <li>• Compressor off</li> <li>• Reserved</li> <li>• Reserved</li> <li>• Service request</li> <li>• Heat pump in heating mode</li> <li>• Heat pump in domestic hot water mode</li> <li>• CH pump on</li> <li>• Locking or Blocking</li> </ul>	Locking or Blocking

**9.5 Description of the parameters**

**9.5.1 Running the back-up in heating mode**

■ **Start-up conditions for the back-up**

The back-ups are authorised to start up normally except in the case of active back-up relief, limitation linked to bi-valency or hybrid mode operation for example.

If the heat pump should also be limited, the back-ups are nevertheless authorised to operate to guarantee heating comfort.

The back-ups can also operate where defrosting is necessary to guarantee the safety of the plate heat exchanger, without taking into account temperature values, bivalency and the BL1 and BL2 inputs.

Conditions that allow back-up relief:

If the **BL function** (AP001) or **BL2 function** (AP100) parameters are set to Backup relieved, Gen.&Backup relieved or Photovoltaic HP Only and the corresponding **BL** input is activated, the back-ups will be deactivated.

In heating mode, the back-up is managed by the following parameters:

Tab.85 Parameter for heating production

Access	Parameter	Description	Default value
 Air Src heat pump > Parameters, counters, signals > Parameters	<b>BL function</b> (AP001)	BL input function selection	<ul style="list-style-type: none"> <li>• Backup relieved</li> <li>• Gen.&amp;Backup relieved</li> <li>• PV HP And backup</li> </ul>
	<b>BL2 function</b> (AP100)	BL2 input function selection.	

Tab.86

Access	Parameter	Description	Value
 23.5 Air Src Heat pump > Parameters, counters, signals > Parameters	<b>Delay StartBackup CH</b> (HP030)	Delay time for starting the backup energy source for the heating circuits Can be set from 1 to 600 minutes. If the <b>Delay StartBackup CH</b> (HP030) parameter is set to 0, the time delay for activating the back-up is set depending on the outdoor temperature.	20 minutes
	<b>Delay stop backup CH</b> (HP031)	Delay time for stopping the backup energy source for the heating circuits	4 minutes (default value)

If the **Delay StartBackup CH** parameter is set to 0, the time delay for activating the back-up is set depending on the outdoor temperature: the lower the outdoor temperature, the quicker the back-up will be activated.

Fig.71

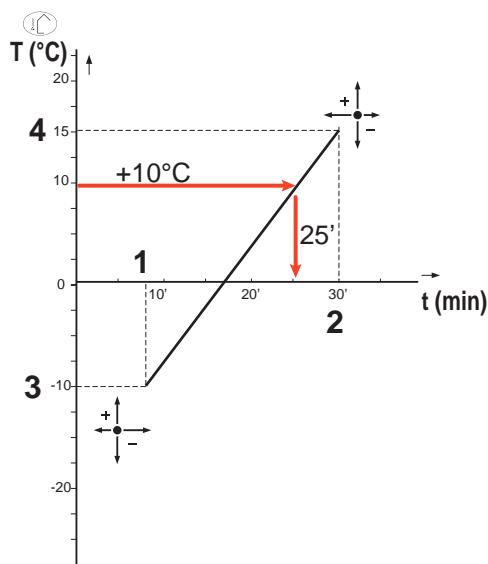

- t Time (minutes)
- T Outdoor temperature (°C)
- 1 Delay Min.Outdoor T. (HP047)
- 2 Delay Max.Outdoor T (HP048)
- 3 Min.Outdoor T.backup (HP049)
- 4 Max.Outdoor T.backup (HP050)

**Important**

In this example, with the factory-set parameters, if the outdoor temperature is 10 °C, the back-up will start up 25 minutes after the outdoor unit of the heat pump.

MW-6000377-6

Tab.87 Time delay curve parameters for tripping the back-up when Delay StartBackup CH (HP030) is set to 0.

Access	Parameter	Description	Value
 23.5 Air Src Heat pump > Parameters, counters, signals > Parameters	Delay Min.Outdoor T. (HP047)	Minimum duration of the time delay for tripping the back-up Can be set from 0 to 60 minutes	8 minutes (default value)
	Delay Max.Outdoor T (HP048)	Maximum duration of the time delay for tripping the back-up. Can be set from 0 to 60 minutes	30 minutes
	Min.Outdoor T.backup (HP049)	Minimum outdoor temperature for the time delay for tripping the back-up. Can be set from -30 to 0 °C	-10 °C
	Max.Outdoor T.backup (HP050)	Maximum outdoor temperature for the time delay for tripping the back-up. Can be set from -30 to +20 °C	15 °C

#### ■ Back-up operation if an error occurs on the outdoor unit

In case of an error on the outdoor unit, the electrical back-up starts immediately to guarantee heating comfort.

#### ■ Back-up operation when defrosting the outdoor unit

When the outdoor unit is defrosting, the control unit ensures the protection of the system by starting up the back-up if necessary.

If the back-up is not sufficient to ensure outdoor unit protection during defrosting, then the outdoor unit is switched off.

#### ■ Operation when the outdoor temperature falls below the operating threshold of the outdoor unit

If the outdoor temperature is below the minimum operating temperature of the outdoor unit as defined by the **Min. Outdoor T. HP (HP051)** parameter, the outdoor unit is not authorised to operate.

Tab.88

Access	Parameter	Description	Value
 <b>Air Src Heat pump &gt; Parameters, counters, signals &gt; Adv. Parameters</b>	Min. Outdoor T. HP (HP051)	Minimum outdoor temperature for the heat pump to shut down.	-15 °C for 4.5 kW -15 °C for 6 kW -20 °C for 8 kW

### 9.5.2 Running the back-up in domestic hot water mode

#### ■ Start-up conditions for the back-up



The start-up conditions for the back-up producing domestic hot water are described in the following table.

Tab.89

Access	Parameter	Description	Adjustment required
 Air Src Heat pump > Parameters, counters, signals > Adv. Parameters	<b>BL function</b> (AP001)	BL input function selection	The operation of the <b>BL1</b> blocking input can be set to: <ul style="list-style-type: none"> <li>• Full blocking</li> <li>• Partial blocking</li> <li>• User reset locking</li> <li>• Backup relieved</li> <li>• Generator relieved</li> <li>• Gen.&amp;Backup relieved</li> <li>• High, Low Tariff</li> <li>• Photovoltaic HP Only</li> <li>• PV HP And backup</li> <li>• Smart Grid ready</li> <li>• Heating Cooling</li> </ul>
	<b>BL1 contact config.</b> (AP098)	BL1 input contact configuration	BL1 input contact configuration: <ul style="list-style-type: none"> <li>• Open</li> <li>• Closed</li> </ul>
	<b>BL2 contact config.</b> (AP099)	BL2 input contact configuration	BL2 input contact configuration: <ul style="list-style-type: none"> <li>• Open</li> <li>• Closed</li> </ul>
	<b>BL2 function</b> (AP100)	BL2 input function selection	The operation of the <b>BL2</b> blocking input can be set to: <ul style="list-style-type: none"> <li>• Full blocking</li> <li>• Partial blocking</li> <li>• User reset locking</li> <li>• Backup relieved</li> <li>• Generator relieved</li> <li>• Gen.&amp;Backup relieved</li> <li>• High, Low Tariff</li> <li>• Photovoltaic HP Only</li> <li>• PV HP And backup</li> <li>• Smart Grid ready</li> <li>• Heating Cooling</li> </ul>

### ■ Operating description

Tab.90 Behaviour of the electrical back-up

Access	Parameter	Operating description	Adjustment required
 DHW tank > Parameters, counters, signals > Parameters	<b>DHW management</b> (DP051)	If set to Economy: the system gives priority to the heat pump during domestic hot water production. Recourse to the electrical back-up is only taken if the <b>Delay StartBackupDHW (DP090)</b> time delay has elapsed in domestic hot water mode, unless hybrid mode is activated. In that case, hybrid logic takes over.	ECO (Only HP)
		If set to Comfort: domestic hot water production mode gives priority to comfort by accelerating domestic hot water production by simultaneously using the heat pump and the electrical back-up. In this mode, there is no maximum time for domestic hot water production as the use of the back-ups helps to ensure domestic hot water comfort more quickly.	Comfort (HP+Boiler)
 DHW tank > Parameters, counters, signals > Adv. Parameters	<b>Delay StartBackupDHW</b> (DP090)	Delay time for starting the backup energy source for DHW	90

### 9.5.3 Operation of the switch between heating and production of domestic hot water

The system does not allow the simultaneous production of heating and domestic hot water.

The switch logic between domestic hot water mode and heating mode operates as follows:

Fig.72

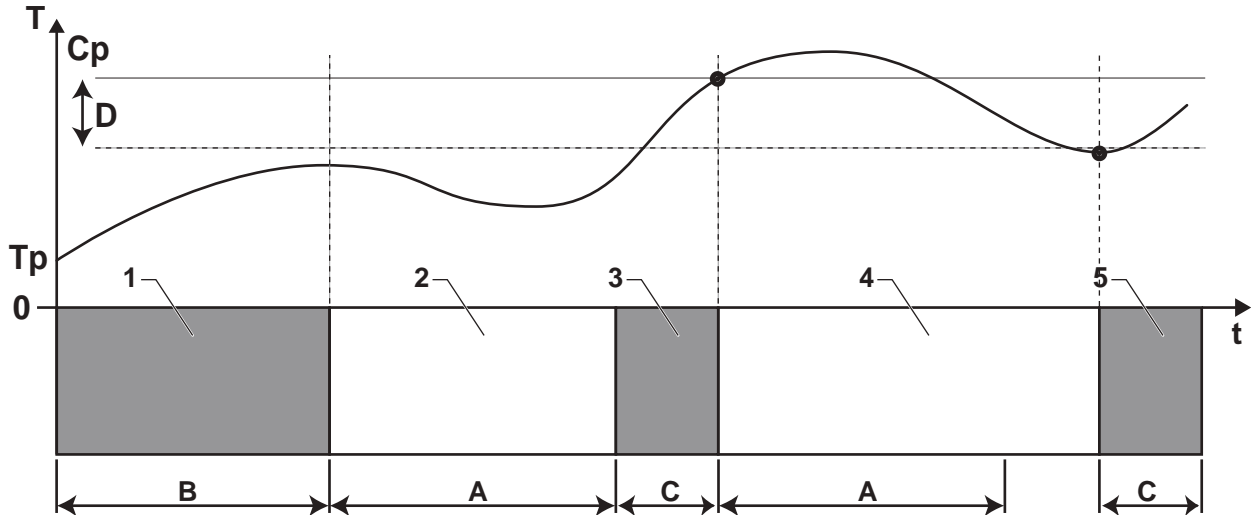

MW-5000541-2

- A** Min. CH before DHW (DP048): Minimum heating duration between two domestic hot water production runs
- B** Max. DHW duration (DP047): Maximum authorised duration for domestic hot water production
- C** Duration for producing domestic hot water (less than DP047) to reach the DHW set point
- Cp** DHW comfort setpoint (DP070): Domestic hot water "Comfort" set point temperature
- D** Hysteresis DHW (DP120): Set point temperature differential triggering the domestic hot water tank to be charged
- DHW reduced setpoint (DP080):** Domestic hot water "Reduced" set point temperature
- T** Temperature
- Tp** DHW tank temp bottom (DM001): Domestic hot water temperature (lower temperature sensor)
- DHW tank temp top (DM006):** Domestic hot water temperature (upper temperature sensor)
- t** Time

Tab.91

Phase	Operating description
1	Domestic hot water production only. When switching on, if domestic hot water production is authorised and acceleration of domestic hot water production is not required, DHW management ((DP051) configured as ECO (Only HP)), a domestic hot water production cycle is started up for a maximum duration that can be adjusted and fixed by the Max. DHW duration(DP047) parameter. In the event of insufficient heating comfort, the heat pump is running too long in domestic hot water mode: reduce the maximum duration of domestic hot water production.
2	Heating only. Production of domestic hot water is off. Even if the domestic hot water set point is not reached, a minimum heating period is forced. This period can be adjusted and defined with the Min. CH before DHW parameter (DP048). After the heating period, tank loading is again enabled.
3	Domestic hot water production only. When the domestic hot water set point is reached, a period in heating mode begins.
4	Heating only. When the Hysteresis DHW(DP120) differential is reached, domestic hot water production is triggered. If there is not enough domestic hot water (e.g. if the domestic hot water does not heat up quickly enough): reduce the trip differential (hysteresis) by modifying the value of the Hysteresis DHW parameter (DP120). The DHW tank will then heat up the water more quickly.
5	Domestic hot water production only.



Tab.92 Configuration of the domestic hot water

Access	Parameter	Description
 <b>DHW tank &gt; Parameters, counters, signalsParameters &gt;</b>	DHW management (DP051)	ECO mode: use of the heat pump only. Comfort mode: use of the heat pump and backup energy sources
	DHW comfort setpoint (DP070)	Comfort temperature setpoint from the Domestic Hot Water tank
	Hysteresis DHW (DP120)	Hysteresis temperature relative to the DHW temperature setpoint
	DHW reduced setpoint (DP080)	Reduced temperature setpoint from the Domestic Hot Water tank

Tab.93 Configuration of the duration

Access	Parameter	Description
 <b>DHW tank &gt; Parameters, counters, signalsParameters &gt;</b>	Max. DHW duration (DP047)	Maximum duration of the domestic hot water production
	Min. CH before DHW (DP048)	Minimum heating duration between two periods of domestic hot water production

Tab.94 Temperatures

Access	Signal	Description
 <b>DHW tank &gt; Parameters, counters, signalsSignals &gt;</b>	DHW tank temp bottom (DM001)	Domestic Hot Water tank temperature (bottom sensor)
	DHW tank temp top (DM006)	Domestic Hot Water tank temperature (top sensor)

## 10 Maintenance

### 10.1 Accessing information on the hardware and software versions

Information about the hardware and software versions of the different appliance components is stored in the user interface.

To access:

1. Press the  key.
2. Select the **Version Information** menu.
3. Select the component for which you would like to see the version information.

Version Information	Description
Appliance information	Information on the indoor unit
EHC-05	Information on the main EHC-05 PCB for the heat pump
MK3	Information on the user interface
SCB-10	Information on the SCB-10 PCB for the heat pump

### 10.2 Configuring the maintenance message

The boiler control panel is used to display a message whenever a service is necessary.

To configure the maintenance message:



1. Select the **Maintenance** icon.
2. Select **Service notification**.
3. Select the desired type of notification:

Type of notification:	Description
None	No maintenance message
Custom notification	The maintenance message will be displayed after the number of heat pump operating hours defined by the <b>Service hours mains</b> parameter: Hours powered to raise a service notification or after the number of compressor operating hours defined by the <b>Maintenance hours</b> parameter.

4. With the **Custom notification** notification type, set the number of operating hours before a maintenance message is sent:

Parameter	Description
Maintenance hours (AP009)	Compressor operating hours before a maintenance message is sent
Service hours mains (AP011)	Operating hours on mains supply before a maintenance message is sent

### 10.3 Checking operation of the appliance

This function is used to force the heat pump and back-up in heating or cooling mode, in order to check that they are working correctly.



1. Press the  key.
2. Select **Commissioning Menu**.
3. Select **Load Test**.
4. Select the operating mode for which you would like to see the information. **Off**, **Medium power** or **Control unit Cooling**.  
 To test operation in heating mode, it is possible to modify the system set point temperature.  
 To test operating in cooling mode, the minimum set point is 10 °C but this can be set to a higher temperature.  
 It is strongly advised not to leave the system in this operating mode for long periods as the heating circuits (mixing valves, pumps) are not regulated.

## 10.4 Standard inspection and maintenance operations



### Caution

Only qualified professionals are authorised to carry out maintenance work on the heat pump and the heating system.



### Caution

Before working on the refrigeration circuit, switch off the appliance and wait a few minutes. Certain items of equipment such as the compressor and the pipes can reach temperatures in excess of 100°C and high pressures, which may cause serious injuries.



### Danger of electric shock

Before any work, switch off the mains electricity to the heat pump and the electrical back-up if present.



### Danger of electric shock

Check the discharge from the capacitors of the outdoor unit.

An annual inspection with a leak-tightness check in accordance with prevailing standards is obligatory.

Maintenance operations are important for the following reasons:

- To guarantee optimum performance.
- To extend the life of the equipment.
- To provide an installation which offers the user optimum comfort over time.



### Caution

Do not drain the installation, except in cases of absolute necessity. E.g.: several months' absence with the risk of temperatures in the building falling below freezing.

### 10.4.1 Checking the safety components

1. Check that the safety components are operating correctly, particularly the safety valve on the heating circuit.
2. Check the electrical connections.
3. Change any and all parts and cables considered defective.
4. Check all screws and nuts (cover, support, etc.).
5. Change damaged sections of lagging.

### 10.4.2 Check the hydraulic pressure

The hydraulic pressure must be at least 0.8 bar. Recommended pressure: 1.5 to 2 bar.

1. Check the hydraulic pressure in the installation.
2. If the hydraulic pressure is too low, top up the water.

### 10.4.3 Cleaning the casing

1. Clean the outside of the appliance using a damp cloth and a mild detergent.

## 10.5 Cleaning the magnetic filter

To prevent clogging of the plate heat exchanger, the magnetic filter on the plate heat exchanger inlet must be cleaned every year as part of annual maintenance.

If the installation has a flow fault, the filter needs to be fully cleaned.

### 10.5.1 Magnetic filter annual maintenance

Fig.73

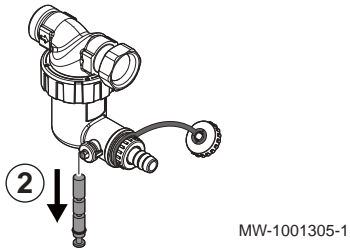

Fig.74

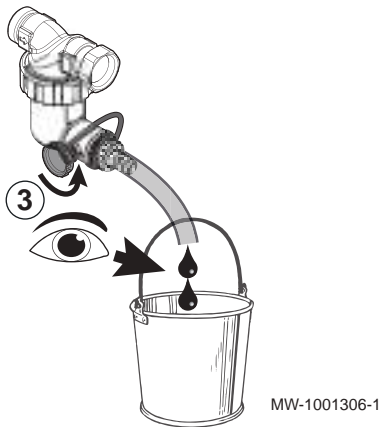

Fig.75

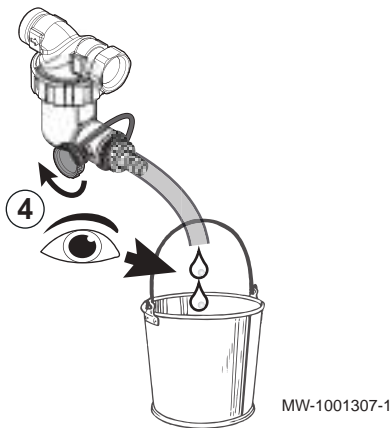
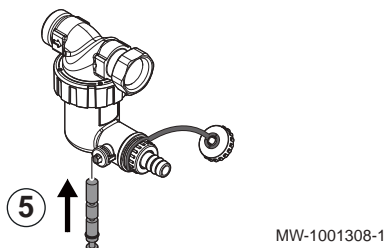

Fig.76



1. Switch off the appliance and close the valves for the heating circuits on the plate.
2. Remove the magnet from the filter.
  - ⇒ The magnetic particles stuck inside the filter will drop to the bottom and be ejected via the drain.

3. Connect a pipe to the filter valve, then open the valve by a quarter turn.

4. Once the water running out of the pipe is clear, re-close the valve. If necessary, open and close the valve several times to create surges, and clean the filter better.

5. Refit the magnet. Pushing it in fully.

Fig.77



MW-1001309-02

6. Check the pressure in the installation. If the pressure is less than 1.5 bar, top up the water.
7. Open the valves on the connection plate.
8. Power the appliance back on.
9. Check the pressure in the installation. If the pressure is less than 1.5 bar, top up the water.
10. Activate the heating and check the flow rate in the installation. If the flow rate is too low, clean the filter fully.

### 10.5.2 Full cleaning of the magnetic filter

If the flow rate in the installation is too low, fully clean the magnetic filter. This operation requires the appliance to be fully drained.

Fig.78

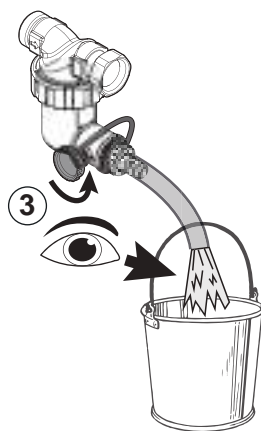

MW-1001310-1

1. Power off the appliance.
2. Isolate the appliance from the water supply.
3. Drain the appliance: connect a drain pipe to the filter nipple, then open the valve on the filter tap by a quarter turn.

Fig.79

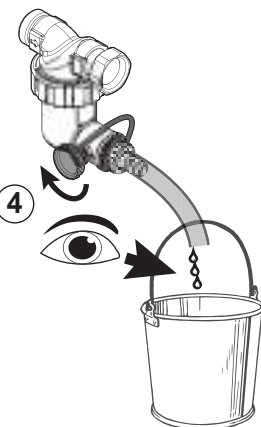

MW-1001311-1

4. Once water stops running out of the pipe, close the valve on the filter.

Fig.80

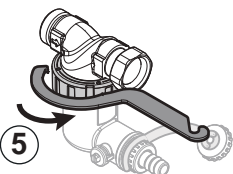

MW-1001312-1

5. Unscrew the sludge container using the handling tool provide in the accessories bag.

Fig.81

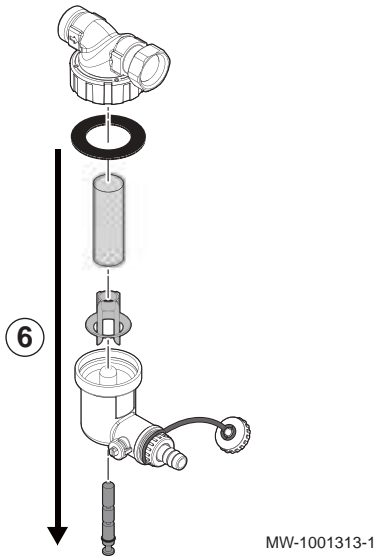

6. Disassemble the different parts of the mud pot.
  - ⇒ The magnetic particles stuck inside the filter body will drop to the bottom.

Fig.82

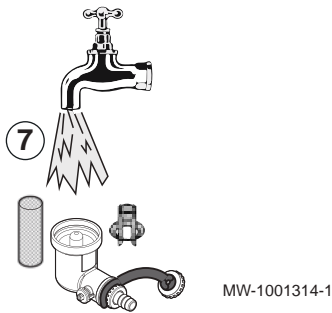

7. Clean the various parts with clean water.

Fig.83

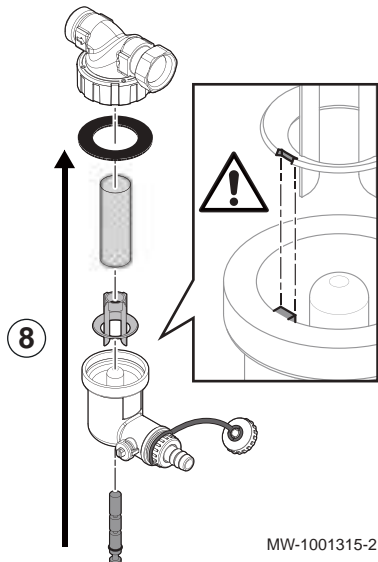

8. Refit the sludge collector.



**Caution**

Risk of breakage.

- Observe the keyway of the plastic part: align the notch with the pin.
- Replace the seal if necessary.
- Check that the seal is correctly positioned before tightening with the key (supplied with the indoor unit).

9. Open the stop valves and reactivate the water supply to the appliance.
10. Re-commission the appliance.

## 10.6 Specific maintenance operations

Fig.84

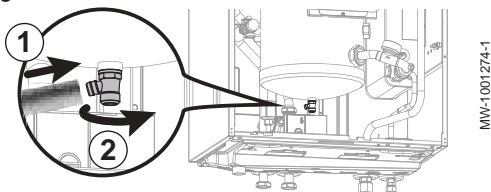

### 10.6.1 Draining the heating circuit

1. Connect a hose (internal diameter: 8 mm) to the drain valve on the heating circuit.
2. Open the drain valve.
3. Await the complete drainage of the heating circuit.

### 10.6.2 Replacing the battery in the control panel

If the indoor module is switched off, the control panel battery takes over to keep the correct time.

The battery must be replaced when the time is no longer saved.

1. Remove the front panel by pulling firmly upwards.
2. Tilt the control panel support forwards.



**Important**

Keep a good hold of the control panel bracket in order not to pull out or disconnect the electrical connections in the control panel.

Fig.85

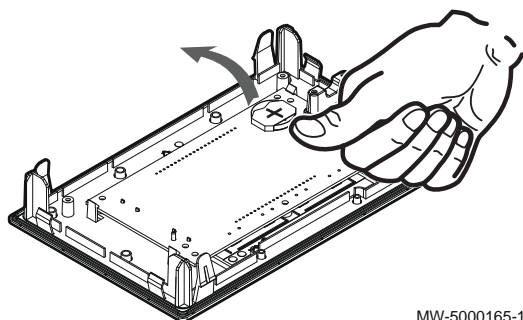

3. Remove the battery located in back plate of the control panel by pushing it gently forwards.
4. Insert a new battery.



**Important**

Battery type:

- CR2032, 3V
- Do not use rechargeable batteries
- Do not discard used batteries in the dustbin. Take them to an appropriate collection place.

5. Re-assemble everything.

# 11 Troubleshooting

## 11.1 Resetting the safety thermostat



**Danger**

Before carrying out any work on the indoor unit, cut off its power supply and the electrical back-up immersion heater.

If you suspect that the safety thermostat was triggered:

1. Cut off the power supply to the indoor unit and the electrical back-up immersion heaters by lowering the circuit breakers on the electric panel.
2. Locate and correct the cause of power cut before resetting the safety thermostat.
3. Remove the front panel of the indoor unit and the protective cap.
4. If the safety thermostat has been triggered, use a flat-headed screwdriver to press the reset button on the thermostat. If not, look for an alternative cause for the power to the immersion heater having been cut.
5. Refit the front panel on the indoor unit and the protective cover.
6. Switch the mains supply to the indoor unit and the electrical back-up immersion heater back on.

Fig.86

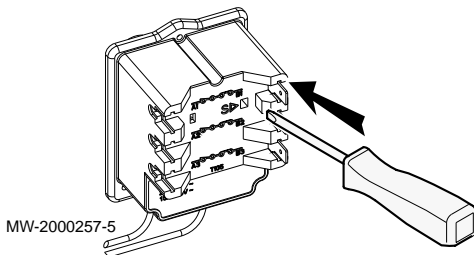

## 11.2 Resolving operating errors

If your appliance malfunctions, the status LED flashes and/or changes colour and a message containing an error code is displayed on the main screen of the control panel. This error code is important for the correct and rapid diagnosis of the type of malfunction and for any technical assistance that may be needed.

If an error occurs:

1. Make a note of the code displayed on the screen.
2. Remedy the problem described by the error code or contact the installer.
3. Switch the heat pump off and back on to check that the cause of the error has been removed.
4. If the code is displayed again, contact the installer.

### 11.2.1 Types of error code

The control panel can display three types of error codes:

Tab.95

Type of code	Code format	Colour of the status LED
Warning	Axx.xx	Green flashing
Blockage	Hxx.xx	Continuous red
Lock out	Exx.xx	Red flashing

### 11.2.2 Error codes

An error code is a temporary status, resulting from the detection of a heat pump anomaly. The heat pump attempts to restart automatically until it switches on.

When one of the following codes is displayed and the heat pump cannot restart automatically, contact a maintenance technician.



Tab.96 List of temporary error codes

Error code	Message	Description
H00.17	<b>DHW sensor Closed</b>	Domestic Hot Water tank temperature sensor is either shorted or measures a temperature above range <ul style="list-style-type: none"> <li>• Check the wiring between the central unit PCB and the sensor.</li> <li>• Check that the sensor has been fitted properly.</li> <li>• Check the Ohmic value of the sensor.</li> <li>• Replace the sensor if necessary.</li> </ul>
H00.32	<b>TOutside Open</b>	Outside temperature sensor is either removed or measures a temperature below range <ul style="list-style-type: none"> <li>• Check the wiring between the central unit PCB and the sensor.</li> <li>• Check that the sensor has been fitted properly.</li> <li>• Check the Ohmic value of the sensor.</li> <li>• Replace the sensor if necessary.</li> </ul> <p>The outdoor temperature sensor must always be connected to the EHC-05 PCB. If you have mistakenly connected the outdoor temperature sensor to the SCB-10 PCB, you must reset the factory settings for the CN1 and CN2 parameters.</p>
H00.33	<b>TOutside Closed</b>	Outside temperature sensor is either shorted or measures a temperature above range <ul style="list-style-type: none"> <li>• Check the wiring between the central unit PCB and the sensor.</li> <li>• Check that the sensor has been fitted properly.</li> <li>• Check the Ohmic value of the sensor.</li> <li>• Replace the sensor if necessary.</li> </ul>
H00.34	<b>TOutside Missing</b>	Outside temperature sensor was expected but not detected <ul style="list-style-type: none"> <li>• Check the wiring between the EHC-05 central unit PCB and the sensor.</li> <li>• Check that the outdoor temperature sensor is connected to the EHC-05 PCB.</li> <li>• Check that the sensor has been fitted properly.</li> <li>• Check the Ohmic value of the sensor.</li> <li>• Replace the sensor if necessary.</li> <li>• Activate automatic detection of all the options and accessories.</li> <li>• Reset the factory settings for the CN1 and CN2 parameters.</li> </ul> <p> <b>Important</b> This solution also resets all the other parameters.</p>
H00.47	<b>HP flow sensor removed or below range</b>	Heat pump flow temperature sensor is either removed or measures a temperature below range <ul style="list-style-type: none"> <li>• Check the wiring between the central unit PCB and the sensor.</li> <li>• Check that the sensor has been fitted properly.</li> <li>• Check the Ohmic value of the sensor.</li> <li>• Replace the sensor if necessary.</li> </ul>
H00.48	<b>THp Flow Closed</b>	Heat pump flow temperature sensor is either shorted or measures a temperature above range <ul style="list-style-type: none"> <li>• Check the wiring between the central unit PCB and the sensor.</li> <li>• Check that the sensor has been fitted properly.</li> <li>• Check the Ohmic value of the sensor.</li> <li>• Replace the sensor if necessary.</li> </ul>
H00.49	<b>THp Flow Missing</b>	Heat pump flow temperature sensor was expected but not detected <ul style="list-style-type: none"> <li>• Check the wiring between the central unit PCB and the sensor.</li> <li>• Check that the sensor has been fitted properly.</li> <li>• Check the Ohmic value of the sensor.</li> <li>• Replace the sensor if necessary.</li> </ul>
H00.51	<b>THp Return Open</b>	Heat pump return temperature sensor is either removed or measures a temperature below range
H00.52	<b>THp Return Closed</b>	Heat pump return temperature sensor is either shorted or measures a temperature above range <ul style="list-style-type: none"> <li>• Check the wiring between the central unit PCB and the sensor.</li> <li>• Check that the sensor has been fitted properly.</li> <li>• Check the Ohmic value of the sensor.</li> <li>• Replace the sensor if necessary.</li> </ul>

Error code	Message	Description
H00.57	<b>T DHW Top Open</b>	Domestic Hot Water top temperature sensor is either removed or measures a temperature below range <ul style="list-style-type: none"> <li>• Check the wiring between the central unit PCB and the sensor.</li> <li>• Check that the sensor has been fitted properly.</li> <li>• Check the Ohmic value of the sensor.</li> <li>• Replace the sensor if necessary.</li> </ul>
H00.58	<b>T DHW Top Closed</b>	Domestic Hot Water top temperature sensor is either shorted or measures a temperature above range <ul style="list-style-type: none"> <li>• Check the wiring between the central unit PCB and the sensor.</li> <li>• Check that the sensor has been fitted properly.</li> <li>• Check the Ohmic value of the sensor.</li> <li>• Replace the sensor if necessary.</li> </ul>
H02.02	<b>Wait Config Number</b>	Waiting For Configuration Number Waiting for configuration parameters to be entered <ul style="list-style-type: none"> <li>• Configure CN1 / CN2 depending on the output of the outdoor unit installed (CNF menu).</li> </ul> Central unit PCB replaced: heat pump not configured
H02.03	<b>Conf Error</b>	Configuration Error The configuration parameters entered are incorrect. <ul style="list-style-type: none"> <li>• Configure CN1 / CN2 depending on the output of the outdoor unit installed (CNF menu).</li> </ul>
H02.04	<b>Parameter Error</b>	Parameter Error <ul style="list-style-type: none"> <li>• Restore the factory settings.</li> <li>• If the error is still present: change the central unit PCB.</li> </ul> PCB settings cannot be read <ul style="list-style-type: none"> <li>• Configure CN1 / CN2 depending on the output of the outdoor unit installed (CNF menu).</li> <li>• Check the correct parameter settings.</li> </ul>
H02.05	<b>CSU CU mismatch</b>	CSU does not match CU type <ul style="list-style-type: none"> <li>• Software change (software number or version parameter inconsistent with the memory).</li> </ul>
H02.07	<b>Water Press Error</b>	Water Pressure Error active <ul style="list-style-type: none"> <li>• Check the hydraulic pressure in the heating circuit.</li> <li>• Check the wiring between the central unit PCB and the pressure sensor.</li> <li>• Check the connection of the pressure sensor.</li> </ul>
H02.09	<b>Partial block</b>	Partial blocking of the device recognized <b>BL</b> input on the central unit PCB terminal block open <ul style="list-style-type: none"> <li>• Check the contact on the <b>BL</b> input.</li> <li>• Check the wiring.</li> <li>• Check the AP001 and AP100. parameters.</li> </ul>
H02.10	<b>Full Block</b>	Full blocking of the device recognized <b>BL</b> input on the central unit PCB terminal block open <ul style="list-style-type: none"> <li>• Check the contact on the <b>BL</b>. input.</li> <li>• Check the wiring.</li> <li>• Check the AP001 and AP100. parameters.</li> </ul>

Error code	Message	Description
H02.23	<b>System flow error</b>	<p>System water flow error active Flow problem Insufficient flow: open a radiator valve. The circuit is clogged:</p> <ul style="list-style-type: none"> <li>• Check that the filters are not obstructed and clean them if necessary.</li> <li>• Clean and flush the installation,</li> </ul> <p>No circulation:</p> <ul style="list-style-type: none"> <li>• Check that the valves and thermostatic valves are open,</li> <li>• Check that the circulating pump is working,</li> <li>• Check the wiring,</li> <li>• Check the pump supply: if the pump does not work, replace it.</li> </ul> <p>Too much air: completely vent the indoor unit and the installation for optimum running. Incorrect wiring: check the electrical connections. Flow meter:</p> <ul style="list-style-type: none"> <li>• Check the electrical connections and the direction of the flow meter (arrow to the right).</li> <li>• Replace the flow meter if necessary</li> </ul>
H02.25	<b>ACI error</b>	<p><b>Titan Active System</b> short circuited or on an open circuit</p> <ul style="list-style-type: none"> <li>• Check the connection cable.</li> <li>• Check that the anode has not short-circuited and is not broken.</li> </ul>
H02.36	<b>Funct device lost</b>	<p>Functional device has been disconnected No communication between the central unit PCB and the additional circuit PCB</p> <ul style="list-style-type: none"> <li>• Check the connection of the supply cable between the PCBs.</li> <li>• Check the connection of the <b>BUS</b> cable between the PCBs.</li> <li>• Run automatic detection.</li> </ul>
H02.37	<b>Uncritic device lost</b>	<p>Uncritical device has been disconnected No communication between the central unit PCB and the additional circuit PCB</p> <ul style="list-style-type: none"> <li>• Check the connection of the supply cable between the PCBs.</li> <li>• Check the connection of the <b>BUS</b> cable and the PCBs.</li> <li>• Run automatic detection.</li> </ul>
H02.60	<b>Unsupported function</b>	The zone doesn't support the selected function
H06.01	<b>HP Unit Failure</b>	<p>Heat Pump Unit Failure occurred Heat pump outdoor unit fault</p> <ul style="list-style-type: none"> <li>• Check the wiring between the central unit PCB and the communication <b>bus</b> on the outdoor unit.</li> <li>• Check the connection of the communication cable between the central unit PCB and the interface PCB.</li> <li>• Check the connection of the supply cable between the central unit PCB and the interface PCB.</li> <li>• Check the connection of the outdoor unit supply cable.</li> </ul>

### 11.2.3 SCB-10 error codes

An error code is a temporary status, resulting from the detection of a heat pump anomaly. The control panel attempts automatic restart of the heat pump until it switches on.

Tab.97

Code	Display text	Description
H00.69	TbufferTankOpen	Buffer Tank temperature sensor is either removed or measures a temperature below range
H00.70	TbufferTankClosed	Buffer Tank temperature sensor is either shorted or measures a temperature above range
H00.71	TbufferTankTopOpen	Buffer Tank top temperature sensor is either removed or measures a temperature below range

Code	Display text	Description
H00.72	TbufferTankTopClosed	Buffer Tank top temperature sensor is either shorted or measures a temperature above range
H00.74	TBufferTankMissing	Buffer Tank temperature sensor was expected but not detected
H00.75	TBufferTankTop Miss	Buffer Tank Top temperature sensor was expected but not detected
H00.76	TcascadeFlow Open	Cascade Flow temperature sensor is either removed or measures a temperature below range
H00.77	TcascadeFlow Closed	Cascade Flow temperature sensor is either shorted or measures a temperature above range
H00.78	TcascadeFlow missing	Cascade Flow temperature sensor was expected but not detected
H02.02	Wait Config Number	Waiting For Configuration Number
H02.03	Conf Error	Configuration Error
H02.04	Parameter Error	Parameter Error
H02.05	CSU CU mismatch	CSU does not match CU type
H02.16	Int CSU Timeout	Internal CSU Timeout
H02.36	Funct device lost	Functional device has been disconnected
H02.40	Function unavailable	Function unavailable
H02.45	Full Can Conn Matrix	Full Can Connection Matrix
H02.46	Full Can Device Adm	Full Can Device Administration
H02.47	Failed Conn Funct Gr	Failed Connecting Function Groups
H02.48	Funct Gr Conf Fault	Function Group Configuration Fault
H02.49	Failed Init Node	Failed Initialising Node
H02.55	Inval or miss SerNR	Invalid or missing device serial number
H02.61	Unsupported function	Zone A doesn't support the selected function
H02.62	Unsupported function	Zone B doesn't support the selected function
H02.63	Unsupported function	Zone C doesn't support the selected function
H02.64	Unsupported function	Zone D doesn't support the selected function
H02.65	Unsupported function	Zone E doesn't support the selected function
H02.66	TAS not connected	The anti corrosion protection (TAS) of the Domestic Hot Water tank is not connected
H02.67	TAS short-circuit	The anti corrosion protection (TAS) of the Domestic Hot Water tank is shortend
H10.00	T Flow Zone A Open	Flow temperature sensor Zone A Open
H10.01	T Flow Zone A Closed	Flow temperature sensor Zone A Closed
H10.02	T DhW Zone A Open	Domestic Hot Water temperature sensor Zone A Open
H10.03	T DhW Zone A Closed	Domestic Hot Water temperature sensor Zone A Closed
H10.04	TSwimmPoolZoneA Open	Swimming Pool Temperature Sensor Zone A Open
H10.05	TSwimmPoolZoneAClose	Swimming Pool Temperature Sensor Zone A Closed
H10.09	T Flow Zone B Open	Flow temperature sensor Zone B Open
H10.10	T Flow Zone B Closed	Flow temperature sensor Zone B Closed
H10.11	T DhW Zone B Open	Domestic Hot Water Temperature Sensor Zone B Open
H10.12	T DhW Zone B Closed	Domestic Hot Water temperature sensor Zone B Closed
H10.13	TSwimmPoolZoneB Open	Swimming Pool Temperature Sensor Zone B Open
H10.14	TSwimmPoolZoneBClose	Swimming Pool Temperature Sensor Zone B Closed
H10.18	T Flow Zone C Open	Flow temperature sensor Zone C Open
H10.19	T Flow Zone C Closed	Flow temperature sensor Zone C Closed
H10.20	T DhW Zone C Open	Domestic Hot Water Temperature Sensor Zone C Open
H10.21	T DhW Zone C Closed	Domestic Hot Water temperature sensor Zone C Closed
H10.22	TSwimmPoolZoneC Open	Swimming Pool Temperature Sensor Zone C Open
H10.23	TSwimmPoolZoneCClose	Swimming Pool Temperature Sensor Zone C Closed
H10.27	T Flow Zone DHW open	Flow temperature sensor Zone DHW open
H10.28	Sens. ZoneDHW closed	Flow temperature sensor Zone DHW closed

Code	Display text	Description
H10.29	Sensor Zone DHW open	Temperature sensor Zone DHW open
H10.30	T Zone DHW closed	Domestic Hot Water temperature sensor Zone DHW closed
H10.36	Sensor Zone AUX open	Flow temperature sensor Zone AUX open
H10.37	Sens. ZoneAUX closed	Flow temperature sensor ZoneAUX closed
H10.38	T Dhw Zone AUX open	Domestic Hot Water temperature sensor Zone AUX open
H10.39	Sens. ZoneAUX Closed	Domestic Hot Water temperature sensor Zone AUX closed

#### 11.2.4 Fault codes

If a fault code is still present after several automatic start-up attempts, the heat pump switches to error mode.

The heat pump will only resume normal operation once the causes of the fault have been eliminated by the installer.

As a result of:

- a manual reset,
- a maintenance message reset.

Tab.98 List of fault codes

Error code	Message	Description
E00.00	TFlow Open	Flow temperature sensor is either removed or measures a temperature below range
E00.01	TFlow Closed	Flow temperature sensor is either shorted or measures a temperature above range
E02.13	Blocking Input	Blocking Input of the Control Unit from device external environment Input <b>BL</b> open. <ul style="list-style-type: none"> <li>• Check the wiring.</li> <li>• Check the component connected to the <b>BL</b>. contact</li> <li>• Check the component connected to the AP001 and AP100. contact</li> </ul>
E02.24	System flow locking	System water flow locking active Insufficient flow: open a radiator valve The circuit is clogged: <ul style="list-style-type: none"> <li>• Check that the filters are not obstructed and clean them if necessary.</li> <li>• Clean and flush the installation.</li> </ul> No circulation: <ul style="list-style-type: none"> <li>• Check that the valves and thermostatic valves are open.</li> <li>• Check that the filters are not obstructed.</li> <li>• Check that the circulating pump is working.</li> <li>• Check the wiring.</li> <li>• Check the pump supply: if the pump does not work, replace it.</li> </ul> Too much air <ul style="list-style-type: none"> <li>• Completely vent the indoor module and the installation for optimum running.</li> <li>• Check that the automatic air vents are properly open (also check the hydroblock).</li> </ul> Incorrect wiring: check the electrical connections. Flow meter: <ul style="list-style-type: none"> <li>• Check the electrical connections and the direction of the flow meter (arrow to the right).</li> <li>• Replace the flow meter if necessary.</li> </ul>

#### 11.2.5 EHC-05 alarm codes

An alarm code is a temporary heat pump status, resulting from the detection of an anomaly. If an alarm code still remains after several automatic start-up attempts, the system goes into fault mode.

Tab.99 List of alarm codes

Error code	Message	Description
A02.06	Water Press Warning	Water Pressure Warning active
A02.18	OBD Error	Object Dictionary Error
A02.22	System flow warning	System water flow warning active
A02.55	Inval or miss SerNR	Invalid or missing device serial number
A02.80	Missing Cascade Ctrl	Missing Cascade controller

### 11.2.6 SCB-10 alarm codes

An alarm code is a temporary heat pump status, resulting from the detection of an anomaly. If an alarm code still remains after several automatic start-up attempts, the system goes into fault mode.

Tab.100

Code	Display text	Description
A00.32	TOutside Open	Outside temperature sensor is either removed or measures a temperature below range
A00.33	TOutside Closed	Outside temperature sensor is either shorted or measures a temperature above range
A00.34	TOutside Missing	Outside temperature sensor was expected but not detected
A02.18	OBD Error	Object Dictionary Error: • Reset <b>CN1</b> and <b>CN2</b>
A02.37	Uncritic device lost	Uncritical device has been disconnected: • Bad connection: check the wiring and connectors. • Faulty SCB PCB: replace SCB PCB
A10.45	RoomTempZoneA miss	Measure of Room Temperature Zone A is missing
A10.46	RoomTempZoneB miss	Measure of Room Temperature Zone B is missing
A10.47	RoomTempZoneC miss	Measure of Room Temperature Zone C is missing
A10.50	T_DHW top D miss	Domestic Hot Water temperature sensor top zone DHW is missing
A10.54	Temp. Zone DHW miss.	Temperature sensor Zone DHW is missing
A10.56	T_DHW Zone AUX miss	Domestic Hot Water temperature sensor Zone AUX is missing

## 11.3 Displaying and clearing the error memory

The error memory stores the 32 most recent errors. You can check the details of each error and then clear it from the error memory.

To display and clear the error memory:



1. Press the **☰** key.
2. Select **Error History**.  
⇒ The list of the 32 most recent errors is displayed with the error code, a short description and the date.
3. Carry out the following actions according to your needs:
  - Show the details of an error: select the desired error.
  - To clear the error memory, press and hold the **✓** rotary knob.

## 12 Decommissioning and disposal

### 12.1 Decommissioning procedure

To decommission the heat pump temporarily or permanently:

1. Switch off the heat pump.
2. Shut off the electrical power supply to the heat pump: outdoor unit and indoor module.
3. Shut off the supply to the electrical back-up if an electrical back-up is present.
4. Drain the central heating system.

### 12.2 Disposal and recycling

Fig.87



#### Warning

Removal and disposal of the heat pump must be carried out by a qualified professional in accordance with prevailing local and national regulations.

1. Switch off the heat pump.
2. Cut the mains supply to the heat pump.
3. Recover the refrigerant in accordance with prevailing regulations.



#### Important

Do not allow the refrigerant to escape into the atmosphere.

4. Disconnect the refrigerant connections.
5. Close the water mains.
6. Drain the installation.
7. Dismantle all hydraulic connections.
8. Dismantle the heat pump.
9. Scrap or recycle the heat pump in accordance with prevailing local and national regulations.

## 13 Spare parts

### 13.1 General

If inspection or maintenance work reveals the need to replace a heat pump component, use only recommended spare parts and equipment.



**Caution**

Only genuine spare parts may be used.



**Important**

To order a spare part, give the reference number shown on the list.

### 13.2 Indoor unit

#### 13.2.1 Casing

Fig.88

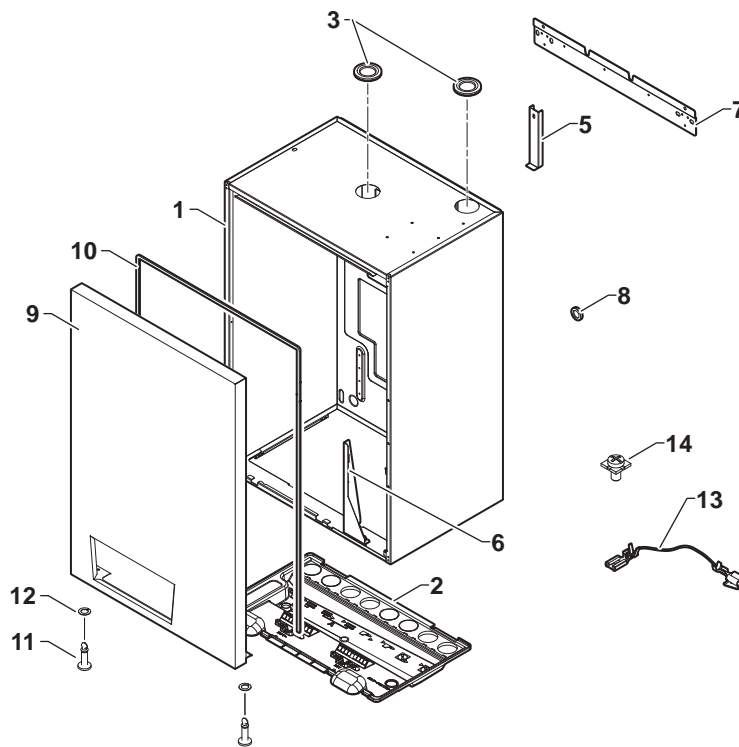

MW-3000616-3

Tab.101

Markers	Reference	Description
1	300025324	Assembled casing
2	300025281	Casing bottom
3	55125	Pipe feed
4	55125	Pipe feed for electrical back-up
5	7666862	Tank blocking plate
6	200020022	Blocking piece for control panel
7	300027772	Casing cross-bar support
8	300025063	Diaphragm cable grommet, dg-pvc 21/e1
9	7683389	Front panel
10	49826	Silicon leak-tightness profile 9 x 7.4
11	S101403	Quarter-turn screw
12	117010	Retaining ring



Markers	Reference	Description
13	7693224	Earth wire, length 1000 mm
14	7665153	Earthing connection nut

### 13.2.2 Control system

Fig.89 Control panel

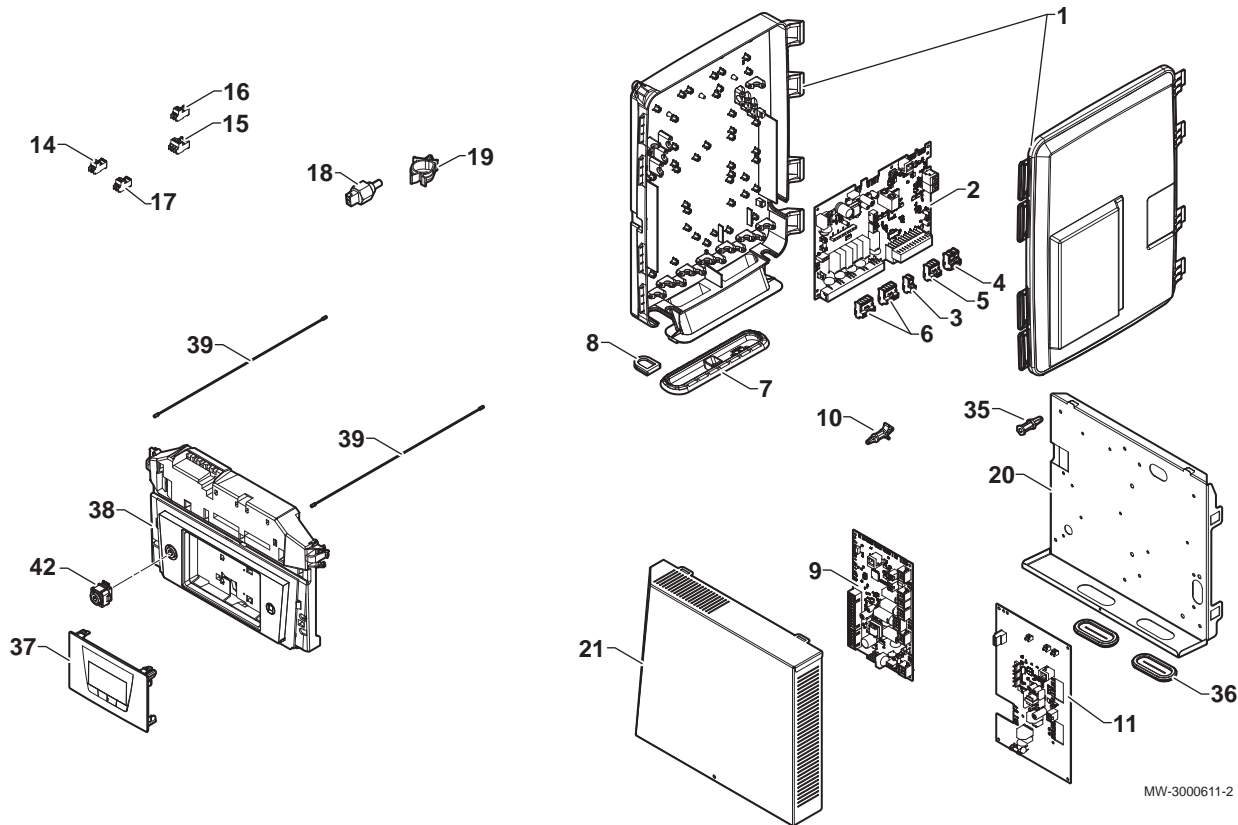

MW-3000611-2

Tab.102 List of spare parts for the control panel

Marker	Reference	Description
1	S100860	SCU casing
2	7704493	SCB-10 PCB
3	7632096	White 2-pin connector
4	7632095	Green 2-pin connector
5	300009102	4-pin telephone relay connector
6	300009081	5-pin connector TS + Pump B + bridge
7	S100869	SCU gasket
8	S100862	SCU grommet (5x)
9	7684855	EHC-05 central unit PCB
10	300020012	Clip-on interface PCB holder series 100-0
11	7653678	HPC-01 interface PCB
14	200009965	2-point BL connector (orange)
15	7685026	rast5 4-pin connector, three-way valve
16	7638205	LUMB 361102f07k13m08 connector
17	300008957	2-pin DHW sensor connector
18	7609871	Pt1000 temperature sensor
19	95320950	Cable clamp
20	7688781	Painted card support
21	7688785	Painted panel cover
35	300020013	Clip-on interface PCB holder series 100-2

Marker	Reference	Description
36	7681470	Oblong grommet membrane
37	7695390	MK3 display for heat pump
38	7676020	Control panel
39	115525	Cord for control panel
42	7675263	Grey complete On/Off switch

Fig.90 PCBs

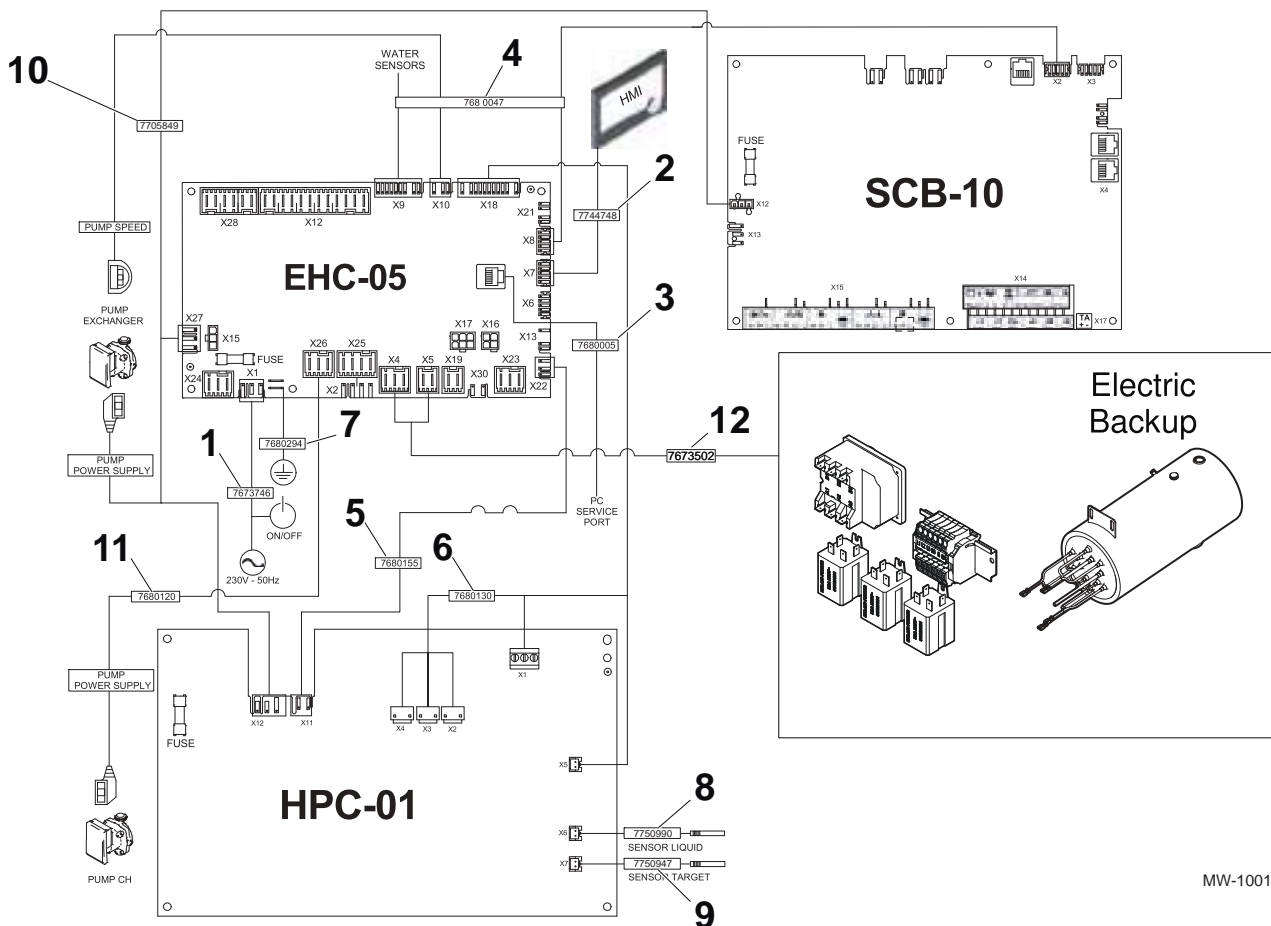

MW-1001291-2

Tab.103 List of spare parts for the PCBs

Marker	Reference	Description
1	7673746	EHC power supply harness
2	7744748	700 mm L-BUS cable
3	7680005	PC operating harness
4	7680047	Sensor harness
5	7680155	S2-S3 cable
6	7680130	EHC-HPC harness
7	7680294	Earth wire
8	7750990	Liquid sensor
9	7750947	Heating sensor
10	7705849	Harness
11	7680120	EHC power supply harness - CH pump
12	7673502	EHC harness, electrical back-up
13	7733655	GTW-30 PCB

13.2.3 Other components

Fig.91

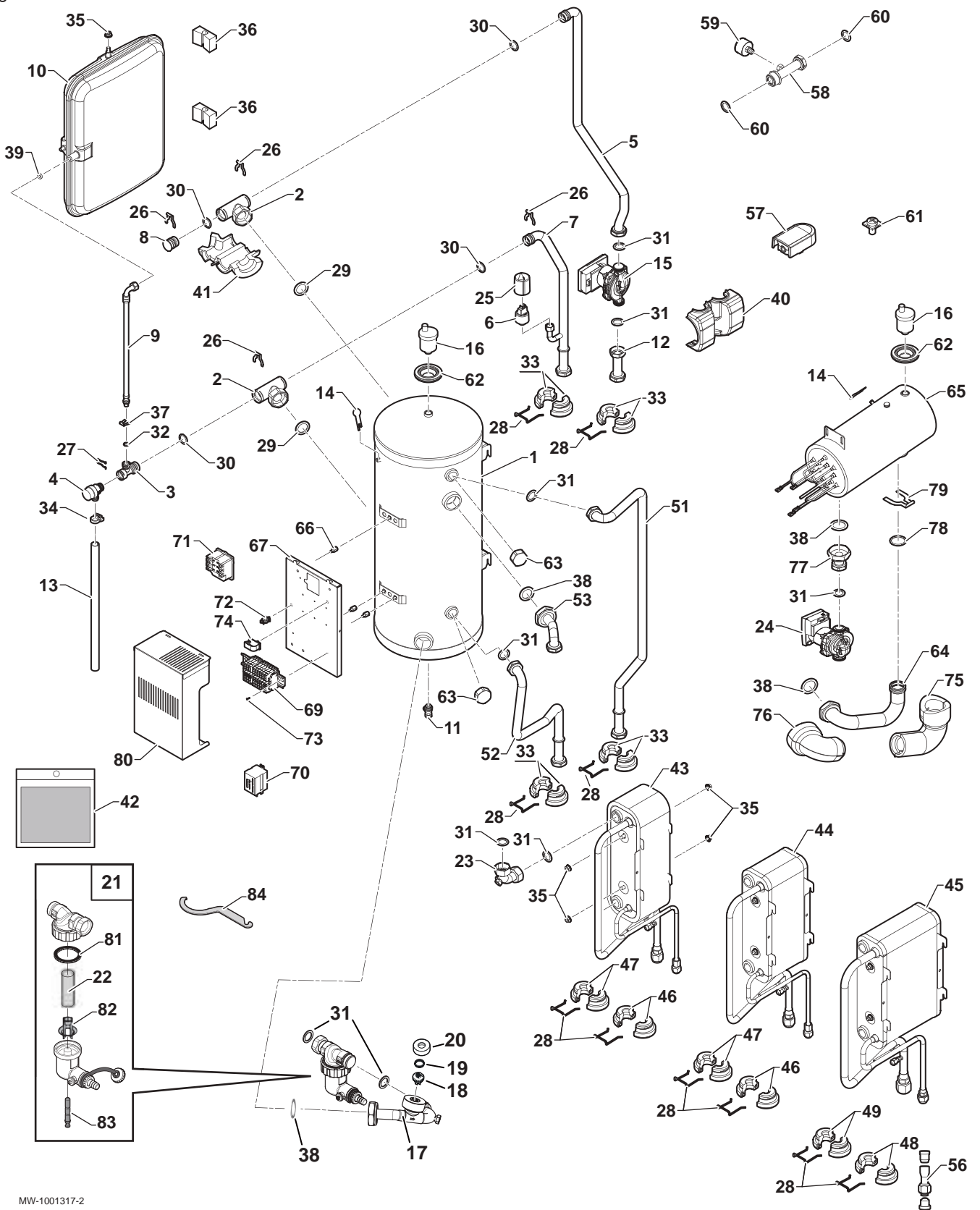

MW-1001317-2

Tab.104

Markers	Reference	Description
1	300025284	Tank unit
2	300025388	Quick-connection T-shaped piece

Markers	Reference	Description
3	300025387	T-shaped safety valve
4	200022010	3.5 bar safety valve
5	7674063	Heating flow pipe, tank
6	7709960	Eltek pressure gauge
7	7674060	Heating return pipe
8	300025325	Quick-release T connection plug
9	300025392	DN8 flexible hose, l450
10	300025395	9510-762 expansion vessel
11	0295174	Drain valve 1/4"
12	300025257	Heating flow pipe, three-way valve
13	300003563	PVC pipe, D20x16
14	300023286	Bulb blocking pin
15	7657318	Y.P.RS15/7.5 RKA 130 9 circulating pump
16	94918138	Automatic air vent
17	7705608	Plate heat exchanger tube, tank
18	300025396	Huba detector head
19	300025363	Wave spring, CS112 l2 0 189
20	300025329	Flow detector nut
21	7697417	Complete magnetic filter
22	7715767	Filter
23	7672888	Circulating pump tube, heating
24	7657259	Circulating pump Y. P. RS15/7.5 PWM 130 12
25	7700519	Pressure gauge protection cap
26	300023113	Pin for DN20
27	116552	Pin clip 20
28	300025361	Spacer clip
29	95013063	Fibre washer, d.38 x 27 x 2
30	95023311	21x3.5 O-ring
31	95013062	Green gasket 30x21x2
32	95023308	O-ring 9.19x2.62 EPDM
33	300025285	Spacer, dia. 22
34	300025444	Hose fastener
35	95890434	Serrated thibloc HM8 nut
36	110865	Tank support bracket
37	300024235	Blocking pin, dia. 10
38	95013064	Green gasket 44x32x2
39	95013058	14x8x2 gasket
40	7681504	Pump insulation
41	300027359	Insulation for T-shaped piece
42	7695163	Screw bag
43	200019610	Plate heat exchanger for 4-8 kW
46	300025290	Spacer, dia 3/8" for 4-16 kW
47	300025291	Spacer, dia 5/8" for 4-16 kW
51	300025235	Return pipe, hydraulic back-up
52	300025237	Flow pipe, hydraulic back-up
53	300025244	Circulating pump pipe, tank
57	95362450	AF60 outdoor temperature sensor
58	7687503	Pipe kit with pressure gauge connector, dia. 22
59	95365106	3 bar axial pressure gauge, dia. 40
60	95013069	22x30x2 green gasket
61	7665153	Earthing connection nut for 4-8 kW
62	55125	Grommet, dia. 60 31/42 thickness 1 mm

Markers	Reference	Description
63	94950198	Brass plug G1" female
64	300025231	Preheater pipe, tank
65	300025332	12 kW preheater
66	300025400	Male-female hexagonal spacer
67	7676000	Electrical back-up support
69	7679295	Terminal connection block, immersion heater
70	96568001	Finder relay, 220 V 30 A
71	200018815	COTHERM BSDP 0002 thermostat and syringe kit
72	95320950	Cable clamp
73	95770690	Sim cb screw, 3.94x9.5
74	300024354	Cable clamp to clip
75	300027995	Preheater pipe insulation 1, tank
76	300027996	Preheater pipe insulation 2, tank
77	300025263	Circulating pump pipe, preheater
78	300025397	O-ring, dia. 34x4
79	300025423	Pin, dia. 35
80	7693269	Electrical back-up cover
81	7715766	Gasket
82	7715768	Plastic insert
83	7715769	Magnet + O-ring
84	7706481	Maintenance key

13.3 Outdoor unit

13.3.1 AWHP 4.5 MR

Fig.92

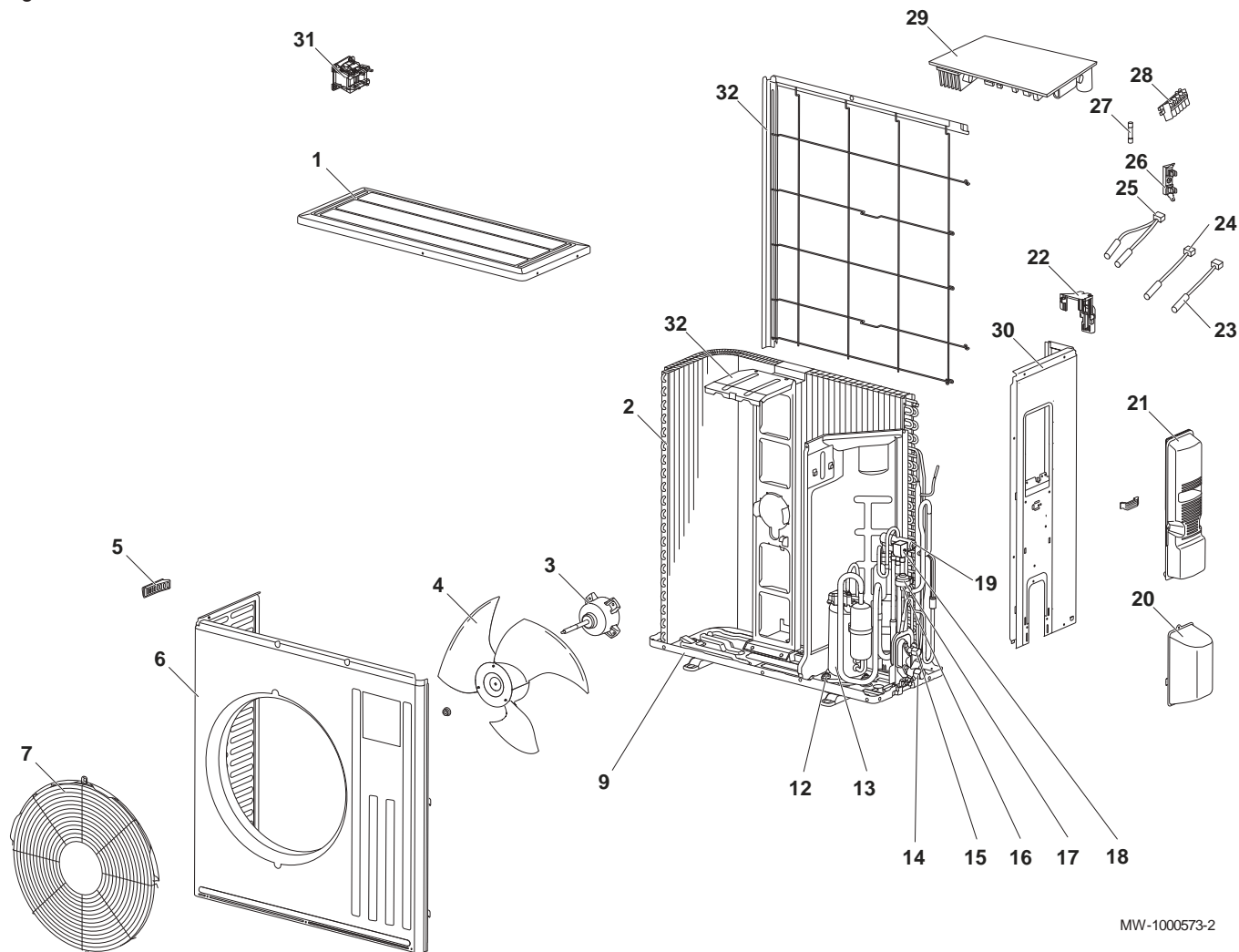

MW-1000573-2

Tab.105

Marker	Reference	Description
1	7652649	Top panel
2	7652667	Coil (evaporator/condenser)
3	7652668	Fan motor
4	7652669	Fan rotor
5	7652670	Grip
6	7652671	Front panel
7	7652672	Fan grate
9	7652673	Base frame
12	7652674	Compressor anti-vibration mount kit
13	7652675	SNB130FGBMT compressor
14	7652676	1/2" stop valve (gas) Ø 12.7 mm
15	7652677	1/4" stop valve (hydraulic) Ø 6.35 mm
16	7652678	Expansion valve
17	7652679	LEV expansion valve coil
18	7652680	21S4 solenoid valve coil
19	7652681	4-way valve
20	7652682	Stop valve access panel
21	7652684	Electrical supply access panel

Marker	Reference	Description
22	7652685	Sensor support
23	7652686	RT65 outdoor temperature sensor
24	7652687	RT68 coil temperature sensor
25	7652688	RT61-RT62 sensor kit
26	7652690	Fuse holder
27	7652691	T20AL / 250 V fuse
28	7652692	Supply terminal
29	7652693	Central unit PCB
30	7652694	Side panel, right
31	7652695	L61 coil
32	7652696	Rear protection grid
33	7652697	Fan motor support
	7652698	Capillary tubes (100) Ø 4 mm x Ø 2.4 mm
	7652699	Condensate discharge

### 13.3.2 AWHP 6 MR-3

Fig.93 Base frame

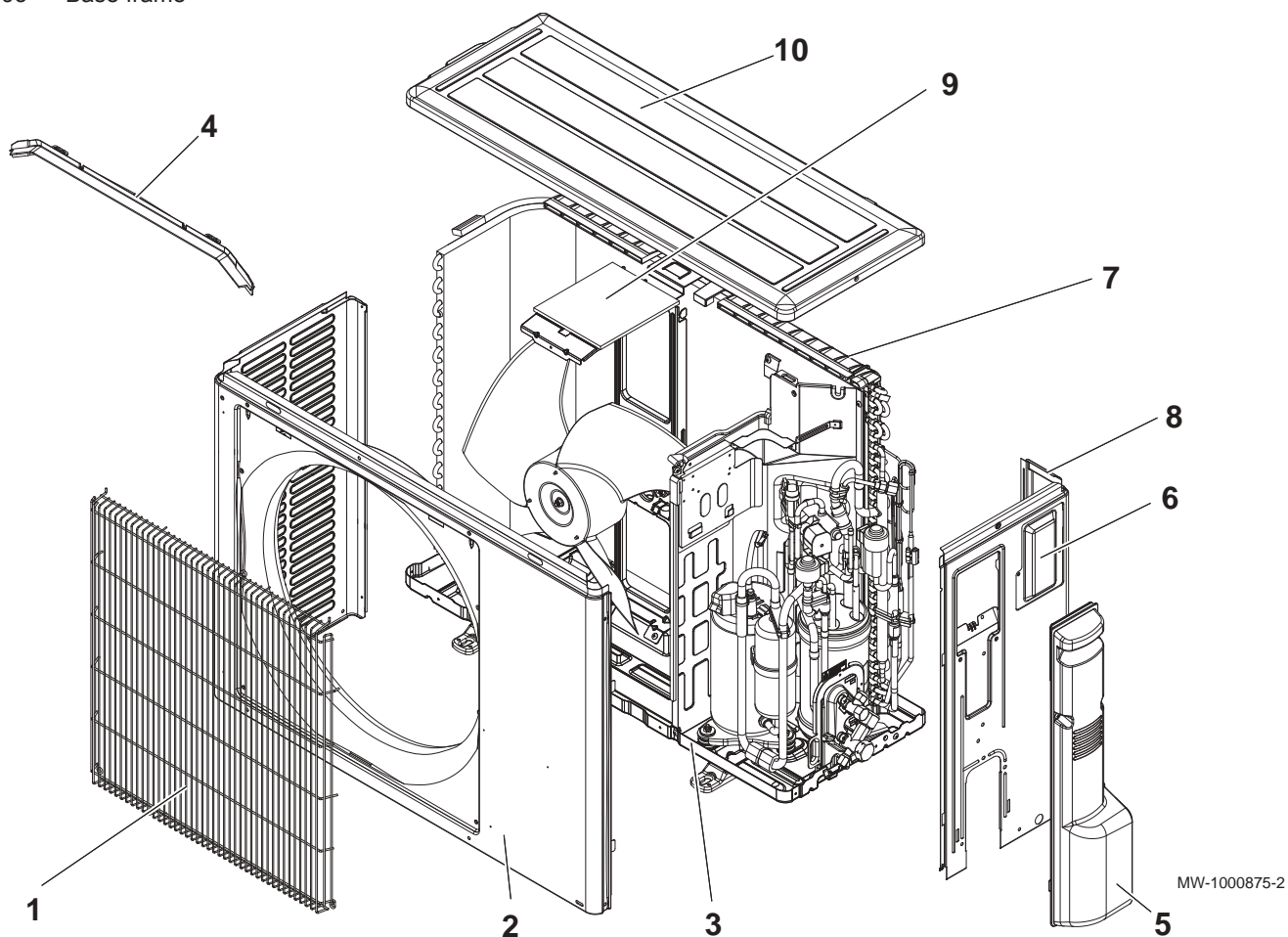

Tab.106

Marker	Reference	Description
1	7673303	Fan grate
2	7673305	Front panel
3	7673306	Base panel
4	7673313	Cable duct
5	7673307	Maintenance access panel

Marker	Reference	Description
6	7673308	Hatch
7	7673309	Rear protection grid
8	7673310	Side panel, right
9	7673311	Motor bracket
10	7673312	Top panel

Fig.94 Electric part

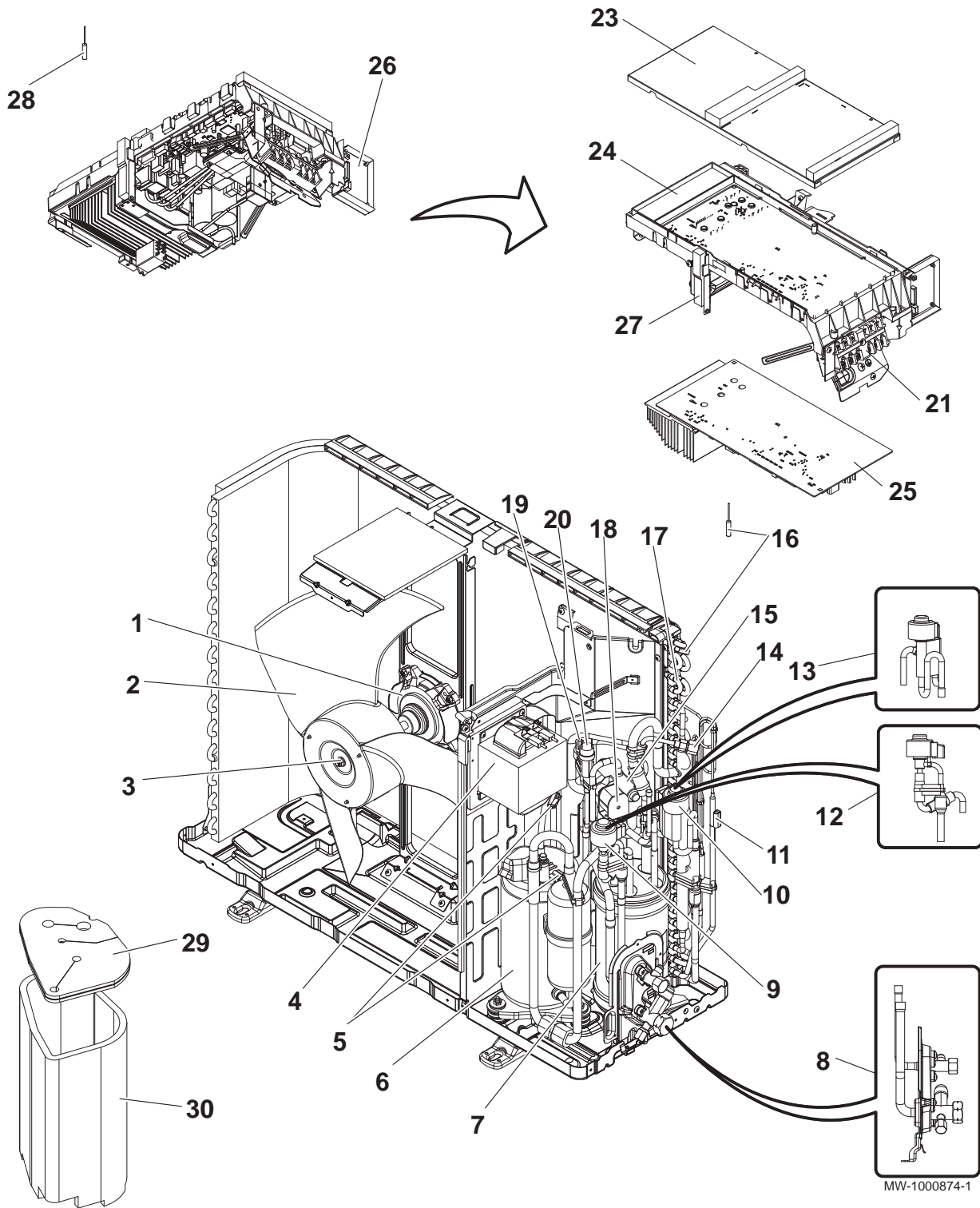



Tab.107

Marker	Reference	Description
1	7673314	Fan motor
2	7673315	Fan rotor
3	7604150	Nut
4	7673316	Self ACL
5	7673317	TH4–TH34 temperature sensor
6	7673318	SNB130FTCM2 compressor
7	7673319	Power receiver
8	7673320	CPLT 1/4 F - 1/2 F stop valves
9	7673321	LEV-B coil
10	7673322	LEV-A coil
11	7673323	TH3 temperature sensor
12	7673324	CPLT LEV-B expansion valve
13	7673325	CPLT LEV-A expansion valve
14	300018092	Load plug
15	300023668	4-way valve
16	7673326	TH6-7 temperature sensor
17	7673327	Coil (evaporator/condenser)
18	7673328	21S4 4-way valve coil
19	7673329	HP pressure switch sensor
20	300018123	41.5-bar HP pressure switch
21	300023673	Connection terminal block
23	7673330	Cover
24	7673331	Support
25	7673332	Central unit PCB
26	7673333	Relay card
27	7673334	Radiator support
28	7673335	TH8 radiator sensor
29	7673336	Compressor top insulation
30	7673337	Compressor insulation
0	7673338	10 A / 250 V fuse
0	7673339	3,15 A / 250 V fuse
0	7673340	Compressor cable harness

13.3.3 AWHP 8 MR-2

Fig.95 AWHP 8 MR-2: base frame

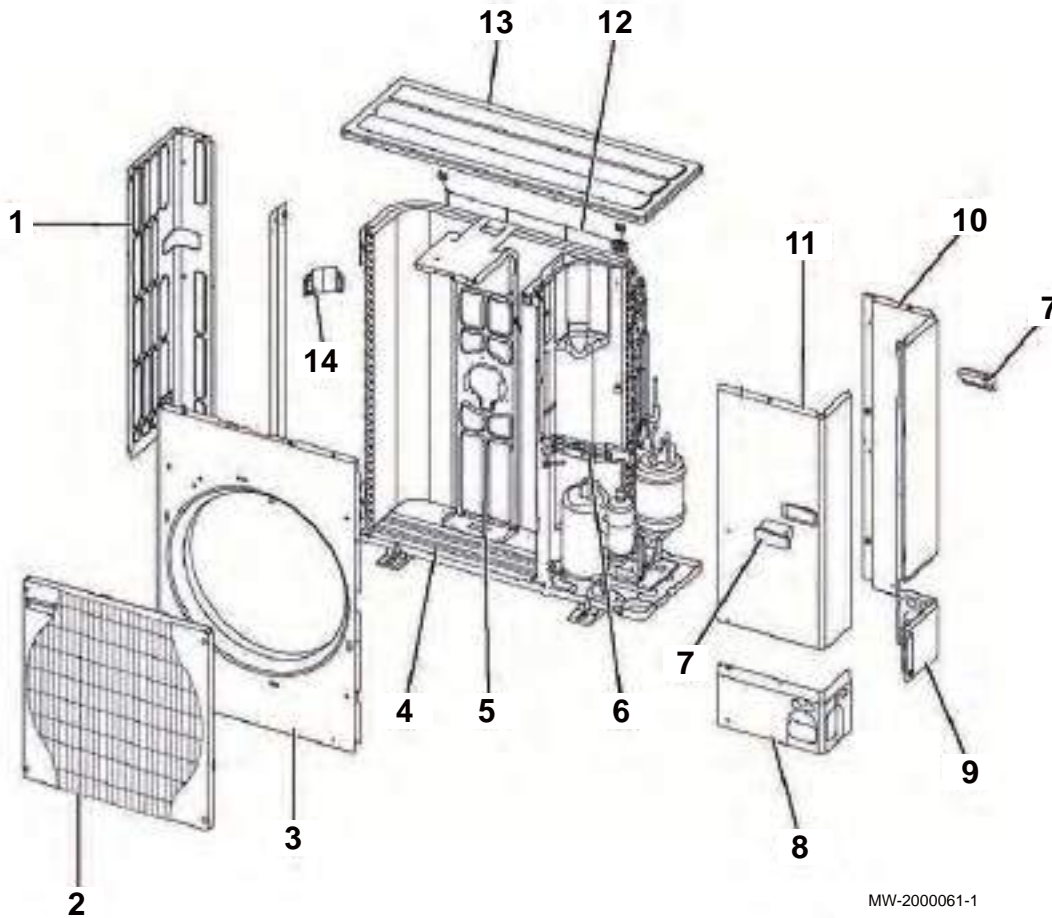

MW-2000061-1

Tab.108

Marker	Reference	Description	Model
1	7614219	Side panel, left	
2	7614220	Fan grid	
3	7614221	Front panel	
4	7614222	Base panel	SERVICE REF. : AWHP 8 MR-2
4	7705552	Base panel	SERVICE REF. : AWHP 8 MR-2 R2.UK
5	7614223	Motor bracket	SERVICE REF. : AWHP 8 MR-2
5	7705553	Motor bracket	SERVICE REF. : AWHP 8 MR-2 R2.UK
6	7614224	Valve bracket	
7	7614225	Grip	
8	7614226	Lower front panel	
9	7614227	Lower rear panel	
10	7614228	Side panel, right	SERVICE REF. : AWHP 8 MR-2
10	7705557	Side panel, right	SERVICE REF. : AWHP 8 MR-2 R2.UK
11	7614230	Maintenance access panel	
12	7614231	Rear protection grate	
13	7614232	Top panel	
14	7614233	Grip	

Fig.96 AWHP 8 MR-2: electric part

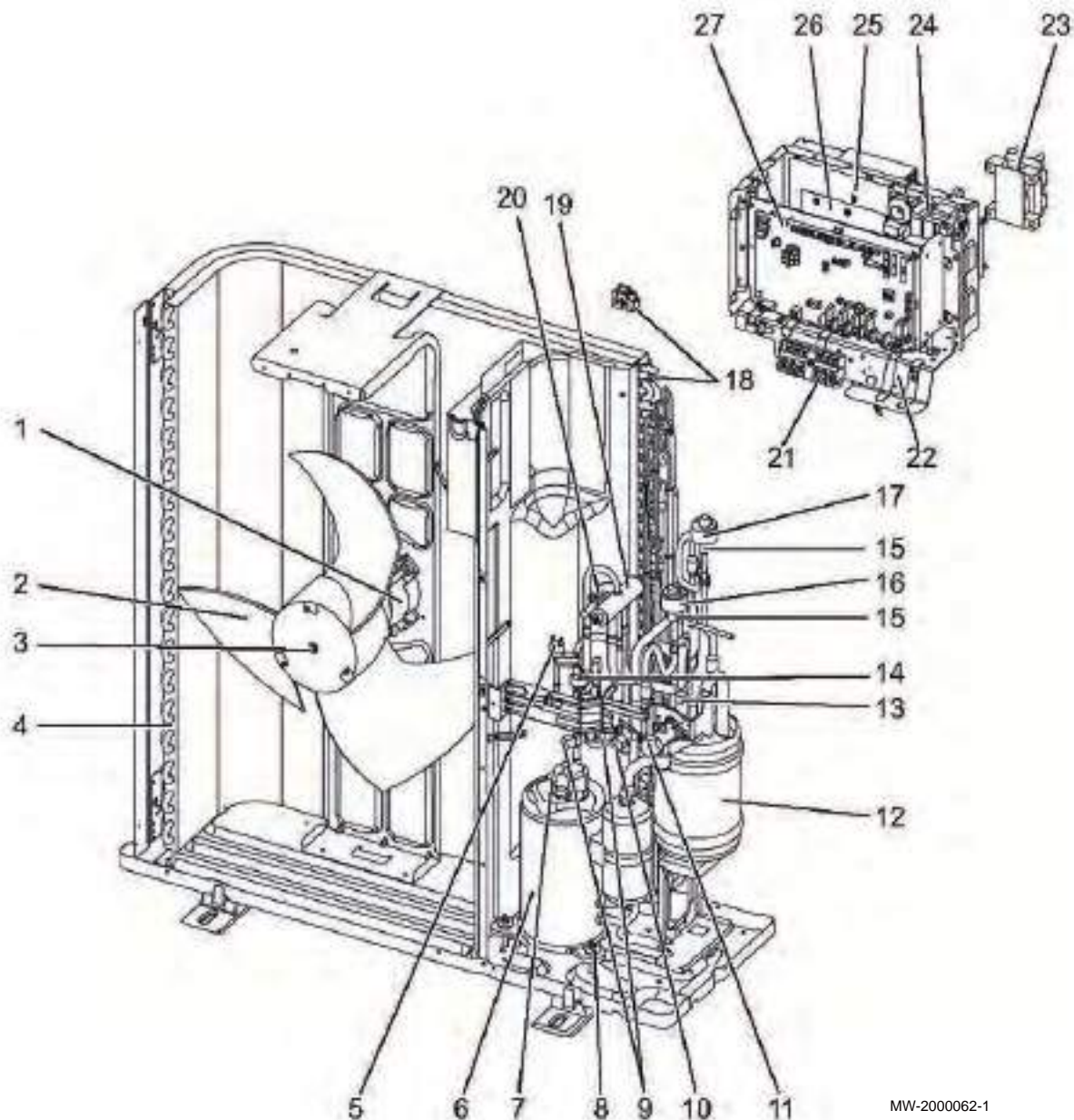

MW-200062-1

Tab.109

Marker	Reference	Description	Model
1	7614234	Fan motor	SERVICE REF. : AWHP 8 MR-2
1	7705558	Fan motor	SERVICE REF. : AWHP 8 MR-2 R2.UK
2	7614236	Fan	
3	7614237	Nut	
4	7614238	Battery (evaporator/condenser)	
5	7614239	High pressure pressure switch	
6	7614240	Compressor TNB220FLHMT	SERVICE REF. : AWHP 8 MR-2
6	7652256	Compressor SNB220FAGMC L1	SERVICE REF. : AWHP 8 MR-2 R1.UK + SERVICE REF. : AWHP 8 MR-2 R2.UK
7	7614241	TH34 compressor discharge temperature sensor	
8	7614242	Anti-vibration stud	SERVICE REF. : AWHP 8 MR-2
8	7705559	Anti-vibration stud	SERVICE REF. : AWHP 8 MR-2 R2.UK
9	7614243	Load plug	
10	7614244	Stop valve 3/8"	

Marker	Reference	Description	Model
11	7614245	Stop valve 5/8"	
12	7614246	Output reserve header	
13	7614247	Filter	
14	7614248	High pressure sensor	
15	7614250	Expansion valve	
16	7614251	Linear expansion valve coil	
17	7614252	Linear expansion valve coil	
18	7614253	Outside sensor battery TH6/7	
19	7614254	4-way valve	
20	7614255	Coil	SERVICE REF. : AWHP 8 MR-2
20	7705561	Coil 21S4	SERVICE REF. : AWHP 8 MR-2 R2.UK
21	7614278	Terminal block	SERVICE REF. : AWHP 8 MR-2
21	7705562	Terminal block	SERVICE REF. : AWHP 8 MR-2 R2.UK
22	7614279	Control panel	
23	7614280	Self (DCL)	SERVICE REF. : AWHP 8 MR-2
23	7705563	Self 18 MH	SERVICE REF. : AWHP 8 MR-2 R2.UK
24	7614282	EMI-suppressor filter	
25	7614283	Dissipator sensor TH8	SERVICE REF. : AWHP 8 MR-2
25	7705564	Dissipator sensor TH8	SERVICE REF. : AWHP 8 MR-2 R2.UK
26	7614284	Output PCB	SERVICE REF. : AWHP 8 MR-2
26	7652259	Output PCB	SERVICE REF. : AWHP 8 MR-2 R1.UK + SERVICE REF. : AWHP 8 MR-2 R2.UK
27	7614285	Central unit PCB	SERVICE REF. : AWHP 8 MR-2
27	7652258	Central unit PCB	SERVICE REF. : AWHP 8 MR-2 R1.UK + SERVICE REF. : AWHP 8 MR-2 R2.UK
0	7614286	Gas sensor TH4	
0	7614288	Liquid sensor TH3	
0	7705560	Silencer	SERVICE REF. : AWHP 8 MR-2 R2.UK

## 14 Reference

# Benchmark Commissioning & Warranty Validation Service Record

It is a requirement that the heat pump is installed and commissioned to the manufacturers' instructions and the data fields on the commissioning checklist completed in full.

To instigate the warranty the heat pump needs to be registered with the manufacturer within one month of the installation. The warranty rests with the end-user (consumer), and they should be made aware it is ultimately their responsibility to register with the manufacturer, within the allotted time period.

It is essential that the heat pump is serviced in line with the manufacturers' recommendations, at least annually. This must be carried out by a competent, certified operative. The service details should be recorded on the Benchmark Service and Interim Heat Pump Work Record and left with the householder. Failure to comply with the manufacturers' servicing instructions and requirements will invalidate the warranty.



[www.hhic.co.uk](http://www.hhic.co.uk)

**This Commissioning Checklist is to be completed in full by the competent person who commissioned the heat pump and associated equipment as a means of demonstrating compliance with the appropriate Building Regulations and then handed to the customer to keep for future reference.**

Failure to install and commission according to the manufacturers' instructions and complete this Benchmark Commissioning Checklist will invalidate the warranty. This does not affect the customer's statutory rights.

\* All installations in England and Wales must be notified to Local Authority Building Control (LABC) either directly or through a Competent Persons Scheme. A Building Regulations Compliance Certificate will then be issued to the customer.

© Heating and Hotwater Industry Council (HHIC)



[www.hhic.org.uk](http://www.hhic.org.uk)  
Issue date: 13.08.2020

# AIR TO WATER HEAT PUMP COMMISSIONING CHECKLIST

Address:												
Heat Pump make and model:												
Heat Pump serial number:												
Commissioned by (PRINT NAME):						Certified Operative Reg number (1):						
Company name:						Telephone number:						
Company email:						Company address:						
										Commissioning date:		
Heating and hot water system complies with the appropriate Building Regulations?											Yes	
DNO notification?											Yes	
Building Regulations Notification Number (if applicable) (2)												
MCS installer registration Number (if applicable)						MCS product certification number (if applicable)						
F-gas certification number (split heat pump only)												
G3 certification number (if applicable)												
Heat Pump Type (Tick)			Split			Monoblock			Peak heat loss of building kW			
Is Heat Pump Installed as part of a cascade?			Yes			Cascade Heat Pump Series			( ) of ( )			
Heat Pump Refrigerant Type						Refrigerant weight						kg
<b>Electrical and Hydronic Controls – SYSTEM AND HEAT PUMP (Tick the appropriate boxes)</b>												
Time and temperature control to heating			Room thermostat and programmer/timer						Programmable Roomstat			
			Load/weather compensation						Optimum start control			
Time and temperature control to hot water			Cylinder thermostat and programmer/timer						Combined with Heat pump main controls			
Hybrid system – synchronised control of boiler and heat pump fitted												Yes
If Yes – boiler model switching point – (Quote Tariff or Temperature Level)												
Heating zone valves (including underfloor loops)			pre-existing			Fitted						Not required
Hot water zone valves			pre-existing			Fitted						Not required
Thermostatic radiator valves			pre-existing			Fitted						Not required
Outdoor Sensor			pre-existing			Fitted						Not required
Heat Pump Safety Interlock (3)			pre-existing			Fitted						Not required
Automatic bypass to system			pre-existing			Fitted						Not required
Buffer Vessel Fitted			Yes			No			If yes volume:			Litres
Plate Heat Exchanger fitted to give hydronic separation of the heat pump circuit to the heating circuit						Yes			No			
Expansion vessel for heating is sized, fitted & charged in accordance with manufacturer's instructions											Yes	
Legionella protection for stored hot water provided by timed temperature control?											Yes	
<b>Water Treatment – SYSTEM AND HEAT PUMP (Tick the appropriate boxes/Measure and Record)</b>												
The system has been flushed/cleaned and a suitable inhibitor applied upon final fill in accordance with BS7593 and manufacturers instructions ?											Yes	
What system cleaner was used?			Brand:			Product:						
What heating system inhibitor was used?			Brand:			Product:						
What heat pump system anti-freeze/inhibitor was used? (monoblock only)			Brand:			Product:			% concentration			
<b>Heat Pump outdoor unit (Tick the appropriate boxes/Measure and Record)</b>												
Is the heating system adequately frost protected and pipes insulated to prevent heat loss?											Yes	
Split only: The refrigerant circuit has been evacuated and charged in accordance with manufacturer's instructions											Yes	
The heat pump is fitted on a solid/stable surface capable of taking its weight											Yes	
The necessary heat pump defrost provision been put in place											Yes	
The heat pump fan free from obstacles and operational											Yes	
Condensate drain installed to manufacturer's instructions											Yes	
<b>CENTRAL HEATING MODE (Tick the appropriate boxes/Measure and Record)</b>												
The heating system has been filled and pressure tested											Yes	
Heating Flow Temperature			°C			Heating Return Temperature			°C			
System correctly balance/rebalanced											Yes	
<b>DOMESTIC HOT WATER MODE (Tick the appropriate boxes)</b>												
Is the heat pump connected to a hot water cylinder?			Unvented			Vented			Thermal Store			Not connected
Hot water cylinder size			Litres			Stored hot water temperature			°C			
Hot water has been checked at all outlets			Yes			Have Thermostatic Blending Valves been fitted?			Yes			Not required

\* All installations in England and Wales must be notified to Local Authority Building Control (LABC) either directly or through a Competent Persons Scheme. A Building Regulations Compliance Certificate will then be issued to the customer.



**ADDITIONAL SYSTEM INFORMATION (Tick the appropriate boxes/Measure and Record)**

Water flow rate setting of the heat pump at commissioning (l/min):													
Additional heat sources connected:		<input type="checkbox"/>	Gas Boiler	<input type="checkbox"/>	Oil Boiler	<input type="checkbox"/>	Electric Heater	<input type="checkbox"/>	Solar Thermal	<input type="checkbox"/>	Other:		

**ALL INSTALLATIONS**

All electrical work complies with the appropriate Regulations	Yes	<input type="checkbox"/>
The heat pump and associated products have been installed and commissioned in accordance with the manufacturer's instructions	Yes	<input type="checkbox"/>
The operation of the heat pump and system controls have been demonstrated to and understood by the customer	Yes	<input type="checkbox"/>
The manufacturer's literature, including Benchmark Checklist and Service Record, has been explained and left with the customer	Yes	<input type="checkbox"/>
Commissioning Engineer's signature:		
Customer's signature (To confirm satisfactory demonstration and receipt of manufacturers' literature)		

\* All installations in England and Wales must be notified to Local Authority Building Control (LABC) either directly or through a Competent Persons Scheme. A Building Regulations Compliance Certificate will then be issued to the customer.





# SERVICE RECORD

It is recommended that your heating system is serviced regularly and that the appropriate Service Interval Record is completed.

## Service provider

Before completing the appropriate Service Record below, please ensure you have carried out the service as described in the manufacturer's instructions.

Always use the manufacturer's specified spare part when replacing controls.

\*A System inhibitor efficacy test is required on every annual service in accordance with the manufacturers' instructions and BS 7593. It is only acceptable to not have undertaken this if the service engineers attendance visit was in between annual services to attend a non-water facing component.

<b>SERVICE 01</b>		Date:
Engineer name:		
Company name:		
Telephone No:		
Operative ID No:		
System inhibitor concentration has been checked and appropriate action taken, in accordance with BS 7593 and heat pump manufacturers' instructions. *	Yes	N/a
Comments:		
Signature:		

<b>SERVICE 01</b>		Date:
Engineer name:		
Company name:		
Telephone No:		
Operative ID No:		
System inhibitor concentration has been checked and appropriate action taken, in accordance with BS 7593 and heat pump manufacturers' instructions. *	Yes	N/a
Comments:		
Signature:		

<b>SERVICE 01</b>		Date:
Engineer name:		
Company name:		
Telephone No:		
Operative ID No:		
System inhibitor concentration has been checked and appropriate action taken, in accordance with BS 7593 and heat pump manufacturers' instructions. *	Yes	N/a
Comments:		
Signature:		

<b>SERVICE 01</b>		Date:
Engineer name:		
Company name:		
Telephone No:		
Operative ID No:		
System inhibitor concentration has been checked and appropriate action taken, in accordance with BS 7593 and heat pump manufacturers' instructions. *	Yes	N/a
Comments:		
Signature:		

<b>SERVICE 01</b>		Date:
Engineer name:		
Company name:		
Telephone No:		
Operative ID No:		
System inhibitor concentration has been checked and appropriate action taken, in accordance with BS 7593 and heat pump manufacturers' instructions. *	Yes	N/a
Comments:		
Signature:		

<b>SERVICE 01</b>		Date:
Engineer name:		
Company name:		
Telephone No:		
Operative ID No:		
System inhibitor concentration has been checked and appropriate action taken, in accordance with BS 7593 and heat pump manufacturers' instructions. *	Yes	N/a
Comments:		
Signature:		

\* All installations in England and Wales must be notified to Local Authority Building Control (LABC) either directly or through a Competent Persons Scheme. A Building Regulations Compliance Certificate will then be issued to the customer.



# SERVICE RECORD

It is recommended that your heating system is serviced regularly and that the appropriate Service Interval Record is completed.

**Service provider**

Before completing the appropriate Service Record below, please ensure you have carried out the service as described in the manufacturer's instructions. Always use the manufacturer's specified spare part when replacing controls.

\*A System inhibitor efficacy test is required on every annual service in accordance with the manufacturers' instructions and BS 7593. It is only acceptable to not have undertaken this if the service engineers attendance visit was in between annual services to attend a non-water facing component.

<b>SERVICE 01</b>		Date:
Engineer name:		
Company name:		
Telephone No:		
Operative ID No:		
System inhibitor concentration has been checked and appropriate action taken, in accordance with BS 7593 and heat pump manufacturers' instructions. *	Yes	N/a
Comments:		
.....		
.....		
.....		
.....		
.....		
<b>Signature:</b>		

<b>SERVICE 01</b>		Date:
Engineer name:		
Company name:		
Telephone No:		
Operative ID No:		
System inhibitor concentration has been checked and appropriate action taken, in accordance with BS 7593 and heat pump manufacturers' instructions. *	Yes	N/a
Comments:		
.....		
.....		
.....		
.....		
.....		
<b>Signature:</b>		

<b>SERVICE 01</b>		Date:
Engineer name:		
Company name:		
Telephone No:		
Operative ID No:		
System inhibitor concentration has been checked and appropriate action taken, in accordance with BS 7593 and heat pump manufacturers' instructions. *	Yes	N/a
Comments:		
.....		
.....		
.....		
.....		
.....		
<b>Signature:</b>		

<b>SERVICE 01</b>		Date:
Engineer name:		
Company name:		
Telephone No:		
Operative ID No:		
System inhibitor concentration has been checked and appropriate action taken, in accordance with BS 7593 and heat pump manufacturers' instructions. *	Yes	N/a
Comments:		
.....		
.....		
.....		
.....		
.....		
<b>Signature:</b>		

\* All installations in England and Wales must be notified to Local Authority Building Control (LABC) either directly or through a Competent Persons Scheme. A Building Regulations Compliance Certificate will then be issued to the customer.



Original instructions - © Copyright

All technical and technological information contained in these technical instructions, as well as any drawings and technical descriptions supplied, remain our property and shall not be multiplied without our prior consent in writing. Subject to alterations.

## FOR UNITED KINGDOM

**For Baxi Customer Support and  
Technical Advice**, contact us at



**0344 871 1545**

Please note calls may be monitored or recorded



**[www.baxi.co.uk](http://www.baxi.co.uk)**

Open Monday - Friday: 8am - 6pm  
Weekends & Bank Holidays: 8.30am - 2pm

Baxi, Brooks House  
Coventry Road, Warwick, CV34 4LL.

## FOR IRELAND

**For Baxi Potterton Myson Customer  
Support and Technical Advice**, contact us at



**00353 (0)1 4590870**

Please note calls may be monitored or recorded



**[www.baxipottertonmyson.ie](http://www.baxipottertonmyson.ie)**

Open Monday - Thursday: 8am - 4.30pm, Friday: 8am - 4pm  
In-Warranty cover on Saturdays: 9am - 12pm October - March.

We are closed on Bank Holidays, Christmas Day and New Year's Day.

Baxi Potterton Myson  
Unit F 5&6, Calmount Park, Calmount Road,  
Ballymount, Dublin 12, Ireland.

CE

**BAXI**

