

Installation and Service Manual

Unvented hot water cylinder range

BAXI ASHP

210 - 300

IMPORTANT

Please read & understand this manual before commencing installation and leave it with the customer for future reference.

Contents

Introduction.....	2
General Requirements	3
Installation - General	5
Installation - Discharge	8
Installation	12
Commissioning - Cylinder.....	13
Maintenance	15
User Instructions.....	16
Fault Finding & Servicing.....	17
Environmental Information.....	18
Spares.....	18
Commissioning Check List.....	22
Service Record	23
Warranty	24
Technical Support.....	24

Introduction

The cylinder is a purpose designed unvented water heater. The unit has a stainless steel inner vessel, which ensures an excellent standard of corrosion resistance. The outer casing is a combination of resilient thermoplastic mouldings and plastic coated corrosion proofed steel sheet. All products are insulated with CFC free polyurethane foam to give good heat loss performance. (see Table 2, page 7)

The unit is supplied complete with all the necessary safety and control devices needed to allow connection to the cold water mains. All these components are preset and not adjustable.

This appliance complies with the requirements of the CE marking directive and is Kiwa approved to show compliance with Building Regulations (Section G3).

The following instructions are offered as a guide to installation which must be carried out by a competent plumbing and electrical installer in accordance with Building Regulation G3, The Building Standards (Scotland) Regulations 1990, or The Building Regulations (Northern Ireland).

NOTE: Prior to installation the unit should be stored in an upright position in an area free from excessive damp or humidity.

IMPORTANT NOTE TO USER: PLEASE REFER TO THE USER INSTRUCTIONS SECTION ON PAGE 20 FOR IMPORTANT INFORMATION WITH RESPECT TO INSTALLATION AND COMMISSIONING CHECKLIST AND SERVICING RECORD



The HWA Charter's Code of Practice requires that all members adhere to the following:

- To supply fit for purpose products clearly and honestly described
- To supply products that meet, or exceed appropriate standards and building and water regulations
- To provide pre and post sales technical support
- To provide clear and concise warranty details to customers

General Requirements

IMPORTANT: This appliance can be used by children aged from 8 years and above and persons with reduced physical sensory or mental capabilities or lack of experience and knowledge if they have been given supervisory or instruction concerning use of the appliance in a safe way and understand the hazards involved.

Children shall not play with the appliance. Cleaning and user maintenance shall not be made by children without supervision.

Also:

- water may drip from the discharge pipe of the pressure-relief device and this pipe must be left open to the atmosphere; (see page 10 for details)

- the pressure-relief device is to be operated regularly to remove lime deposits and to verify that it is not blocked; (see page 15 for details)

- how hot water can be drained. (see page 15 for more details)

- the type or characteristics of the pressure-relief device and how to connect it; (see Fig. 2, page 5 for details and Fig. 5, page 11 for the installation schematic)

- a discharge pipe connected to the pressure-relief device is to be installed in a continuously downward direction and in frost free environment; (see Fig. 4 , page 10 for details)

- details on how to set the temperature controls for the immersion backup heater and boiler controls can be found in section "Commissioning Instructions" (see page 13 for details).

- each circuit must be protected by a suitable double pole isolating switch with a contact separation of at least 3 mm in both poles (see page 12 for details).

- recommended minimum water pressure 0.15 MPa (1.5 bar). Max water pressure 1.6 MPa (16 bar), see page 4 for details.

WARNING: Do not switch on if there is a possibility that the water in the heater is frozen.

Siting The Unit

The cylinder must be vertically floor mounted. Although location is not critical, the following points should be considered:

- The cylinder should be sited to ensure minimum dead leg distances, particularly to the point of most frequent use.
- Avoid siting where extreme cold temperatures will be experienced. All exposed pipe work should be insulated.
- The discharge pipe work from the safety valves must have minimum fall of 1:200 from the unit and terminate in a safe and visible position.
- Access to associated controls and immersion heaters must be available for the servicing and maintenance of the system. Where these controls are installed against a wall a minimum distance of 250 mm must be left (see Fig. 1, below).
- Each circuit must be protected by a suitable double pole isolating switch with a contact separation of at least 3 mm in both poles.
- Ensure that the floor area for the cylinder is level and capable of permanently supporting the weight when full of water. (see Table 2, Page 7)
- Please bear in mind the length of the Heat Pump DHW cable when siting the cylinder.

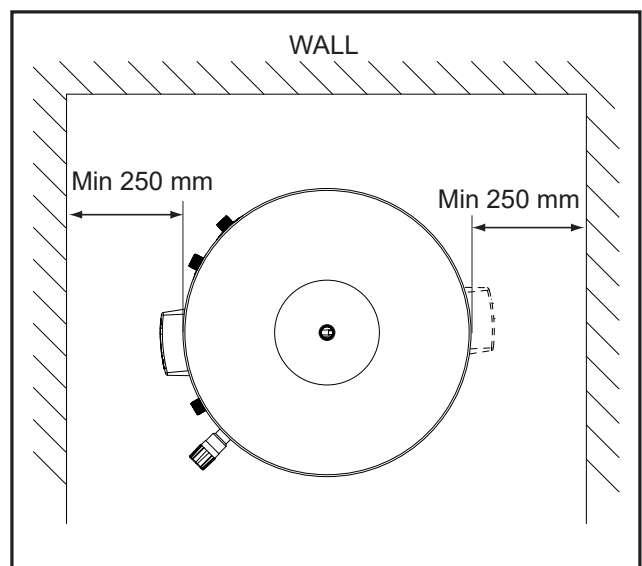

Fig. 1: Siting the Unit

Water Supply

Please bear in mind that the mains water supply to the property will be supplying both the hot and cold water requirements simultaneously.

It is recommended that the maximum water demand is assessed and the water supply checked to ensure this demand can be satisfactorily met.

Note: A high mains water pressure will not always guarantee high flow rates.

Wherever possible the mains supply pipe should be 22 mm. We suggest the minimum supply requirements should be 0.15 MPa (1.5 bar) pressure and 20 litres per minute flow-rate. However, at these values outlet flow rates may be poor if several outlets are used simultaneously. The higher the available pressure and flow rate the better the system performance.

The cylinder has an operating pressure of 0.30 MPa (3.0 bar) which is controlled by the cold water combination valve assembly. The cold water combination valve assembly can be connected to a maximum mains pressure of 1.6 MPa (16 bar).

IMPORTANT INSTALLATION NOTE:

WHERE THE INLET SUPPLY TO THE PRESSURE REDUCING VALVE (PRV) IS ROUTED THROUGH A HEATED SPACE AND IS FITTED WITH A CHECK VALVE OR OTHER FITTING THAT WOULD PREVENT BACK FLOW, HIGH PRESSURES CAN BE EXPERIENCED IN THE INLET PIPE DUE TO WARMING THAT CAN CAUSE DAMAGE TO THE PRV OR OTHER FITTINGS ON THE INLET SUPPLY.

IN THESE CIRCUMSTANCES, THE INSTALLATION OF A MEANS TO ACCOMMODATE EXPANSION AND THUS LIMIT THE PRESSURE RISE IN THE INLET PIPE IS RECOMMENDED. REFER TO THE INSTALLATION SECTION FOR FURTHER DETAILS.

Outlet/Terminal Fittings (Taps, etc.)

The cylinder can be used with most types of terminal fittings. It is advantageous in many mixer showers to have balanced hot and cold water supplies. In these instances a balanced cold water connection is available on the cold water combination valve assembly (see Fig. 5, page 11). Outlets situated higher than the cylinder will give outlet pressures lower than that at the heater, a 10 m height difference will result in a 1 bar pressure reduction at the outlet. All fittings, pipe work and connections must have a rated pressure of at least 6 bar at 80 °C.

Limitations

The cylinder should not be used in association with any of the following:

- Solid fuel boilers or any other boiler in which the energy input is not under effective thermostatic control, unless additional and appropriate safety measures are installed.
- Ascending spray type bidets or any other class 1 back siphonage risk requiring that a type A air gap be employed.
- Steam heating plants unless additional and appropriate safety devices are installed.
- Situations where maintenance is likely to be neglected or safety devices tampered with.
- Water supplies that have either inadequate pressure or where the supply may be intermittent.
- Situations where it is not possible to safely pipe away any discharge from the safety valves.
- In areas where the water consistently contains a high proportion of solids, e.g. suspended matter that could block the strainer, unless adequate filtration can be ensured.
- In areas where the water supply contains chloride levels that exceed 250 mg/L.

Checklist

- Unvented cylinder
- Cold control pack
 - Tundish
 - 3.5 bar Pressure Reducing Valve
 - 6 bar Pressure relief valve
 - 3 port motorised diverter valve
 - Tool - Element spanner
 - Expansion vessel 18 L (210L)
 - Expansion vessel 24 L (250L & 300L)
 - Signal cable 13 m
 - Compression nuts & olives
- Literature pack
 - Installation manual
 - Warranty registration card

Installation General

Pipe Fittings

All pipe fittings are made via 22 mm compression fittings directly to the unit. The fittings are threaded 3/4" BSP male parallel, should threaded pipe connections be required.

Cold Feed

A 22 mm cold water supply is recommended, however, if a 15 mm (1/2") supply exists, which provides sufficient flow, this may be used (although more flow noise may be experienced).

An isolation valve or servicing valve should be incorporated into the cold water supply to enable the cylinder and its associated controls to be isolated and serviced.

Cold Water Valve Assembly

The inlet valve can be connected anywhere on the cold water mains supply prior to the unvented cylinder. There is no requirement to site it close to the unit, it can be located at a point where the mains supply enters the premises if this is more convenient (see Fig. 5, page 11). The valve incorporates the pressure reducer, strainer, expansion valve and check valve. Ensure that the valve is installed with the direction of flow arrows pointing in the correct direction. No other valves should be placed between the pressure relief valve and the cylinder. The pressure relief valve should be installed with the discharge pipe work in either the horizontal position or facing downwards, if fitted inverted, debris may be deposited on the seat and cause fouling of the seat.

Drain Valve

A suitable drain valve should be installed in the cold water supply to the cylinder between the expansion valve (see Fig. 5, page 11) and the heater at a lower level as possible. It is recommended that the outlet point of the drain pipe work be at least 1 metre below the level of the heater (this can be achieved by attaching a hose to the drain valve outlet spigot).

Secondary Circulation

If secondary circulation is required it is recommended that it be connected to the cylinder as shown (see Fig. 6, page 11)

The secondary return pipe should be in 15 mm pipe and incorporate a check valve to prevent back-flow. A suitable WRAS approved circulation pump will be required. On large systems, due to the increase in system water content, it may be necessary to fit an additional expansion vessel to the secondary circuit. This should be done if the capacity of the secondary circuit exceeds 10 litres.

Pipe capacity (copper):

15 mm O.D. = 0.13 L/min (10 litres = 77 m)

22 mm O.D. = 0.38 L/min (10 litres = 26 m)

28 mm O.D. = 0.55 L/min (10 litres = 18 m)

Outlet

The hot water outlet is a 22 mm compression fitting located at the top of the cylinder. Hot water distribution pipe work should be 22 mm pipe with short runs of 15 mm pipe to terminal fittings such as sinks and basins. Pipe sizes may vary due to system design.

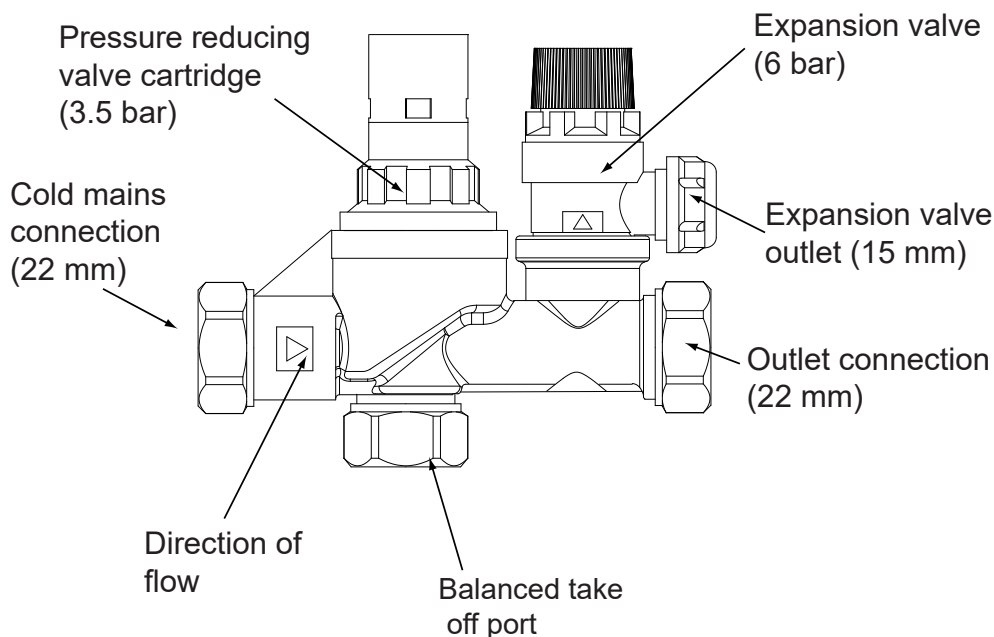

WARNING:
IF THERE IS AN UPSTREAM CHECK VALVE OR FITTING WHICH MAY PREVENT BACKFLOW THEN HIGH PRESSURES CAN BE EXPERIENCED DUE TO AMBIENT TEMPERATURES. THIS MAY CAUSE DAMAGE TO THE VALVES AND FITTINGS.

Fig. 2: Cold Water Valve Assembly

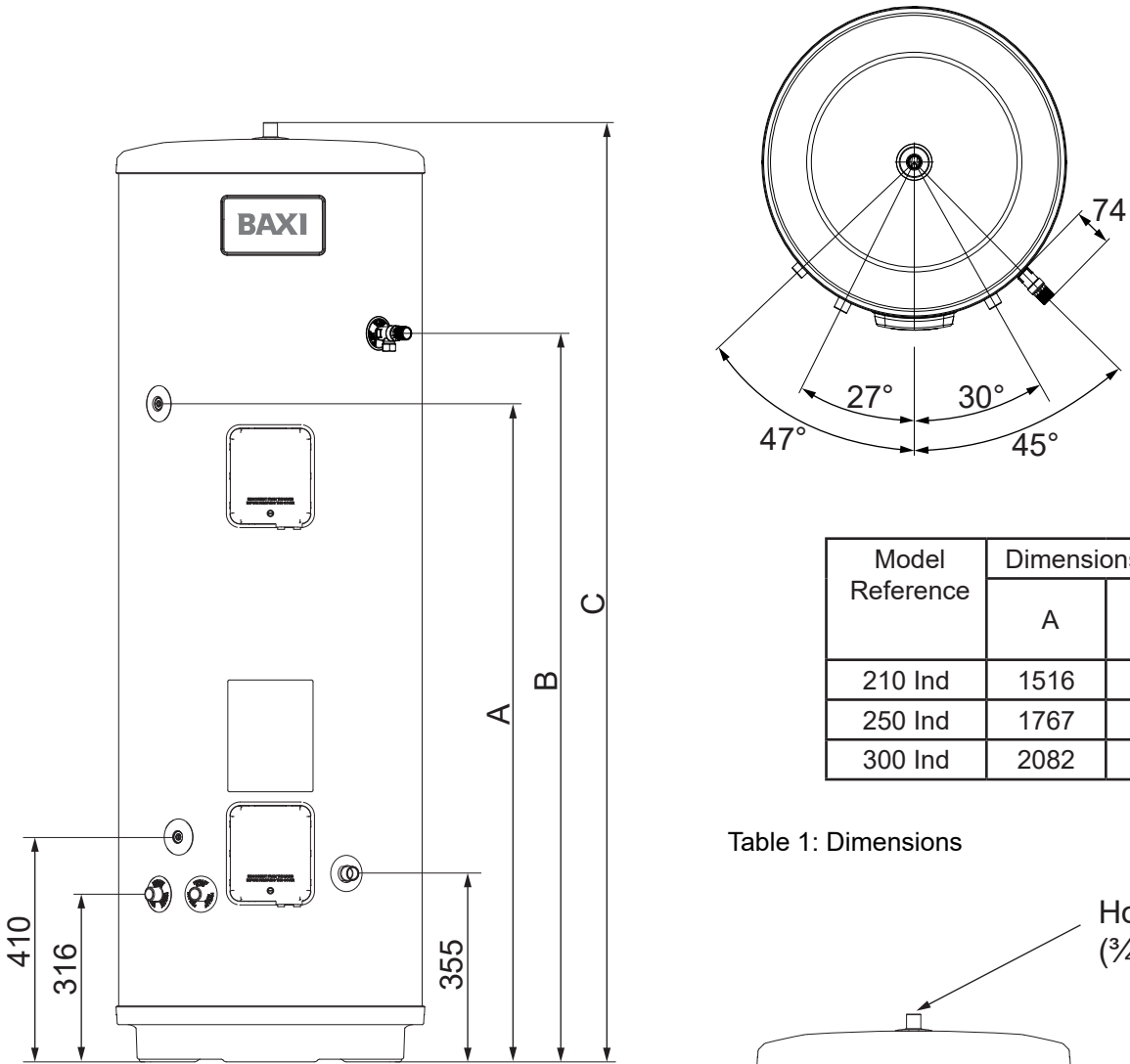

Model Reference	Dimensions (mm)	
	A	B
210 Ind	1516	1085
250 Ind	1767	1310
300 Ind	2082	1561

Table 1: Dimensions

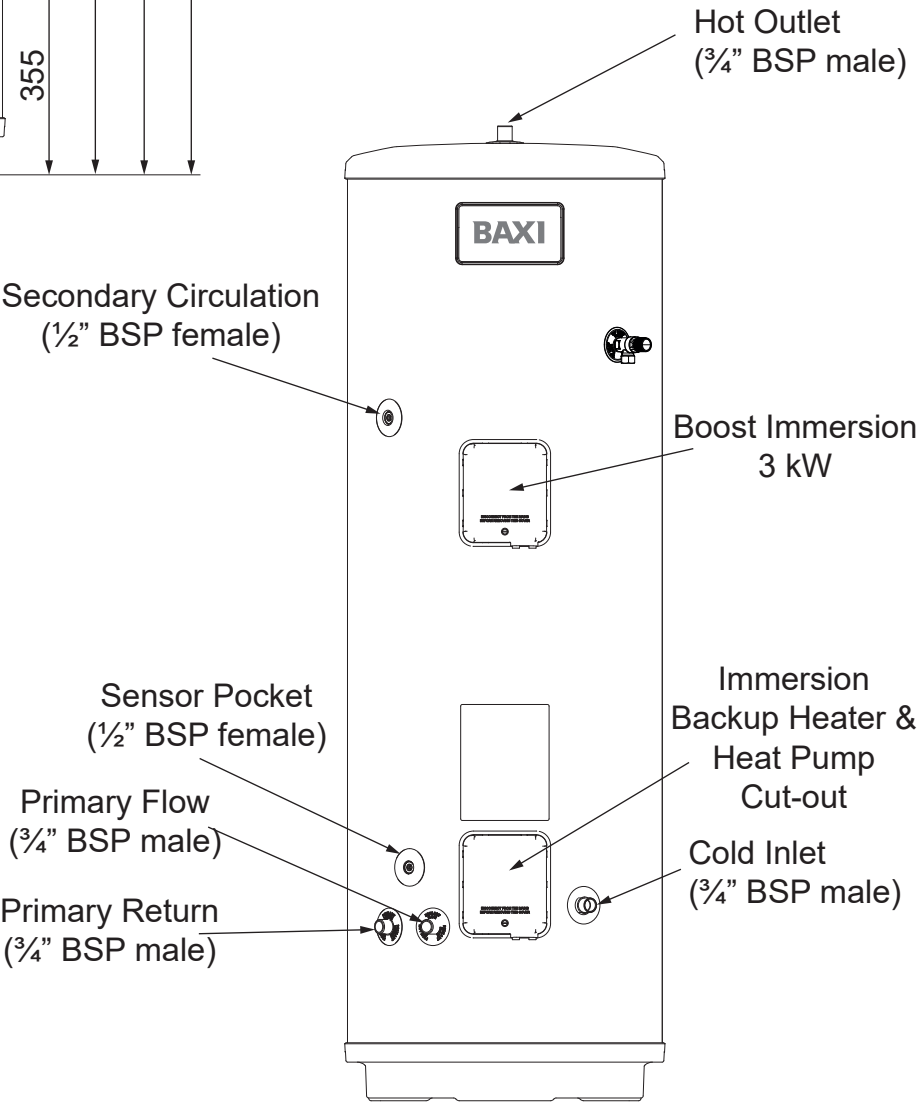

Fig. 3: General Dimensions and Connections

	210	250	300	
Immersion rating (kW)	3	3	3	
Immersion heat up times (min) - Boost immersion ²	67	67	67	
Coil surface area (m ²)	2 m ²	3 m ²		
Coil Volumes (litres)	5.2	8.9		
Coil heat up time ¹ (min)	@15 L/min	21.5	22.8	27.8
Coil rating ¹ (kW)	@15 L/min	33.2	36.8	35.5
Pressure drop through coil ¹ (bar)	@15 L/min	0.41	0.58	
Hot water capacity (volume to >40 °C) Litres	204	242	289	
Weight empty (kg)	46	54	62	
Weight full (kg)	255	300	349	
Volume (litres)	209	246	287	
Standing Heat-loss (kWh/24 h)	1.5	1.78	2.05	
Max mains pressure	16 bar			
Max design pressure	6 bar			
Operating pressure/PRV set pressure	3.5 bar			
Max Primary Pressure	3 bar			
Expansion relief valve setting	6 bar			
T&P valve setting	10 bar/ 90°C			
T&P Part number	95605810			
Rated Pressure	8 bar			
Immersion heaters electrical rating	3 kW@240 V/2.7 kW@230 V			

Table 2: Performance

Notes:

- 1: Cylinders tested in conformance to Annex A, BS EN 12897:2016
- 2: Temperature rise 50 °C (10 - 60 °C)

Models	210L	250L	300L
Energy Efficiency Class	B	C	C
Storage Volumes V in litres	210	250	300
Standing Loss in W/h	62	74	85

Table 3: Technical parameters in accordance with European Commission regulations 814/2013 and 812/2013

Installation Discharge

Discharge Pipework

It is a requirement of Building Regulation G3 that any discharge from an unvented system is conveyed to where it is visible, but will not cause danger to persons in or about the building. The tundish and discharge pipes should be fitted in accordance with the requirements and guidance notes of Building Regulation G3. The G3 Requirements and Guidance section 3.50 - 3.63 are reproduced in the following sections of this manual. For discharge pipe arrangements not covered by G3 guidance advice should be sought from your local Building Control Officer. Any discharge pipe connected to the pressure relief devices (expansion valve and temperature/pressure relief valve) must be installed in a continuously downward direction and in a frost free environment.

Water may drip from the discharge pipe of the pressure relief device. This pipe must be left open to the atmosphere. The pressure relief device is to be operated regularly to remove lime deposits and to verify that it is not blocked.

G3 REQUIREMENT

“...there shall be precautions...to ensure that the hot water discharged from safety devices is safely conveyed to where it is visible but will not cause danger to persons in or about the building.”

The following extract is taken from the latest G3 Regulations

Discharge pipes from safety devices

Discharge pipe D1

3.50 Each of the temperature relief valves or combined temperature and pressure relief valves specified in 3.13 or 3.17 should discharge either directly or by way of a manifold via a short length of metal pipe (D1) to a tundish.

3.51 The diameter of discharge pipe (D1) should be not less than the nominal outlet size of the temperature relief valve.

3.52 Where a manifold is used it should be sized to accept and discharge the total discharge from the discharge pipes connected to it.

3.53 Where valves other than the temperature and pressure relief valve from a single unvented hot water system discharge by way of the same manifold that is used by the safety devices, the manifold should be factory fitted as part of the hot water storage system unit or package.

Tundish

3.54 The tundish should be vertical, located in the same space as the unvented hot water storage system and be fitted as close as possible to, and lower than, the valve, with no more than 600 mm of pipe between the valve outlet and the tundish (see Fig. 4, page 9).

Note: To comply with the Water Supply (Water Fittings) Regulations, the tundish should incorporate a suitable air gap.

3.55 Any discharge should be visible at the tundish. In addition, where discharges from safety devices may not be apparent, e.g. in dwellings occupied by people with impaired vision or mobility, consideration should be given to the installation of a suitable safety device to warn when discharge takes place, e.g. electronically operated.

Discharge pipe D2

3.56 The discharge pipe (D2) from the tundish should:

- (a) have a vertical section of pipe at least 300 mm long below the tundish before any elbows or bends in the pipework (see Fig. 4, page 9); and*
- (b) be installed with a continuous fall thereafter of at least 1 in 200.*

3.57 The discharge pipe (D2) should be made of:

- (a) metal; or*
- (b) other material that has been demonstrated to be capable of safely withstanding temperatures of the water discharged and is clearly and permanently marked to identify the product and performance standard (e.g. as specified in the relevant part of BS 7291).*

3.58 The discharge pipe (D2) should be at least one pipe size larger than the nominal outlet size of the safety device unless its total equivalent hydraulic resistance exceeds that of a straight pipe 9 m long, i.e. for discharge pipes between 9 and 18 m the equivalent resistance length should be at least two sizes larger than the nominal outlet size of the safety device; between 18 and 27 m at least 3 sizes larger, and so on; bends must be taken into account in calculating the flow resistance. (See Table 4, page 10), and the worked example.

Note: An alternative approach for sizing discharge pipes would be to follow Annex D, section D.2 of BS 6700:2006 Specification for design, installation, testing and maintenance of services supplying water for domestic use within buildings and their curtilages.

3.59 Where a single common discharge pipe serves more than one system, it should be at least one pipe size larger than the largest individual discharge pipe (D2) to be connected.

3.60 The discharge pipe should not be connected to a soil discharge stack unless it can be demonstrated that the soil discharge stack is capable of safely withstanding temperatures of the water discharged, in which case, it should:

- (a) contain a mechanical seal, not incorporating a water trap, which allows water into the branch pipe without allowing foul air from the drain to be ventilated through the tundish;
- (b) be a separate branch pipe with no sanitary appliances connected to it;
- (c) if plastic pipes are used as branch pipes carrying discharge from a safety device they should be either polybutalene (PB) to Class S of BS 7291-2:2006 or cross linked polyethylene (PE-X) to Class S of BS 7291-3:2006; and
- (d) be continuously marked with a warning that no sanitary appliances should be connected to the pipe.

Note:

1. Plastic pipes should be joined and assembled with fittings appropriate to the circumstances in which they are used as set out in BS EN ISO 1043-1.
2. Where pipes cannot be connected to the stack it may be possible to route a dedicated pipe alongside or in close proximity to the discharge stack.

Termination of discharge pipe

3.61 The discharge pipe (D2) from the tundish should terminate in a safe place where there is no risk to persons in the vicinity of the discharge.

3.62 Examples of acceptable discharge arrangements are:

- (a) to a trapped gully with the end of the pipe below a fixed grating and above the water seal;
- (b) downward discharges at low level; i.e. up to 100 mm above external surfaces such as car parks, hard standings, grassed areas etc. are acceptable providing that a wire cage or similar guard is positioned to prevent contact, whilst maintaining visibility; and
- (c) discharges at high level: e.g. into a metal hopper and metal down pipe with the end of the discharge pipe clearly visible or onto a roof capable of withstanding high temperature discharges of water and 3 m from any plastic guttering system that would collect such discharges.

3.63 The discharge would consist of high temperature water and steam. Asphalt, roofing felt and non-metallic rainwater goods may be damaged by such discharges.

Worked Example of Discharge Pipe Sizing

Fig. 4: shows a G1/2 temperature relief valve with a discharge pipe (D2) having 4 No. elbows and length of 7 m from the tundish to the point of discharge.

From Table 4, page 10:

Maximum resistance allowed for a straight length of 22 mm copper discharge pipe (D2) from a G1/2 temperature relief valve is 9 m.

Subtract the resistance for 4 No. 22 mm elbows at 0.8 m each = 3.2 m

Therefore the permitted length equates to: 5.8 m

5.8 m is less than the actual length of 7 m therefore calculate the next largest size.

Maximum resistance allowed for a straight length of 28 mm pipe (D2) from a G1/2 temperature relief valves equates to 18 m.

Subtract the resistance of 4 No. 28 mm elbows at 1 m each = 4 m

Therefore the maximum permitted length equates to: 14 m

As the actual length is 7 m, a 28 mm (D2) copper pipe will be satisfactory.

Warnings:

- Under no circumstances should the factory fitted temperature/pressure relief valve be removed other than by a competent person. To do so will invalidate any guarantee or claim.
- The cold water combination valve assembly must be fitted on the mains water supply to the cylinder.
- No control or safety valves should be tampered with or used for any other purpose.
- The discharge pipe should not be blocked or used for any other purpose.
- The tundish should not be located adjacent to any electrical components.

VALVE OUTLET SIZE	MINIMUM SIZE OF DISCHARGE PIPE D1	MINIMUM SIZE OF DISCHARGE PIPE D2 FROM TUNDISH	MAXIMUM RESISTANCE ALLOWED, EXPRESSED AS A LENGTH OF STRAIGHT PIPE (I.E. NO ELBOWS OR BENDS)	RESISTANCE CREATED BY EACH ELBOW OR BEND
G1/2	15 mm	22 mm 28 mm 35 mm	UP TO 9 m UP TO 18 m UP TO 27 m	0.8 m 1.0 m 1.4 m
G3/4	22 mm	28 mm 35 mm 42 mm	UP TO 9 m UP TO 18 m UP TO 27 m	1.0 m 1.4 m 1.7 m
G1	28 mm	35 mm 42 mm 54 mm	UP TO 9 m UP TO 18 m UP TO 27 m	1.4 m 1.7 m 2.3 m

Table 4: Sizing of copper discharge pipe (D2) for common temperature relief valve outlet sizes

NOTE: The table below is based on copper pipe. Plastic pipes may be of different bore and resistance. Sizes and maximum lengths of plastic should be calculated using data prepared for the type of pipe being used.

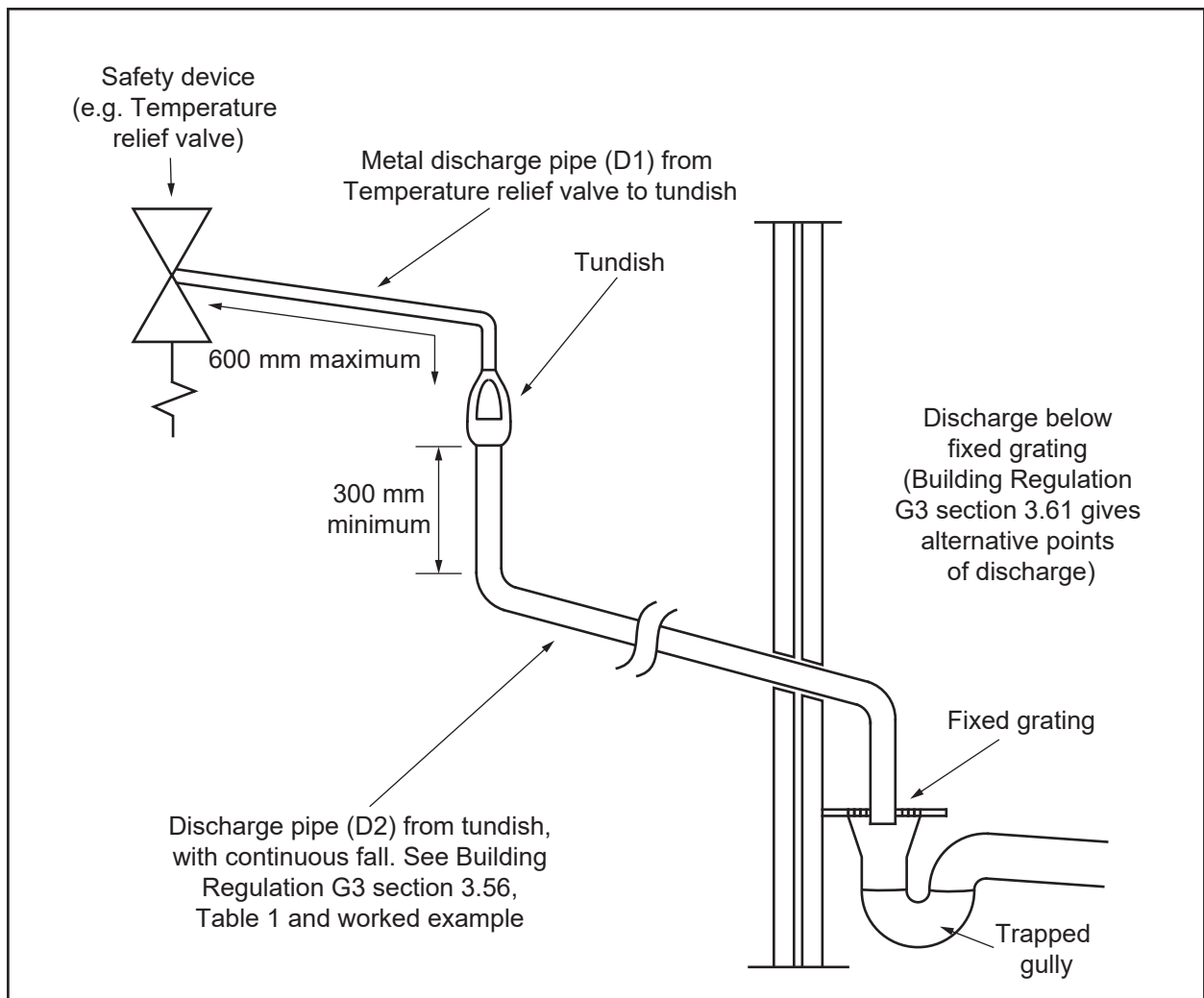
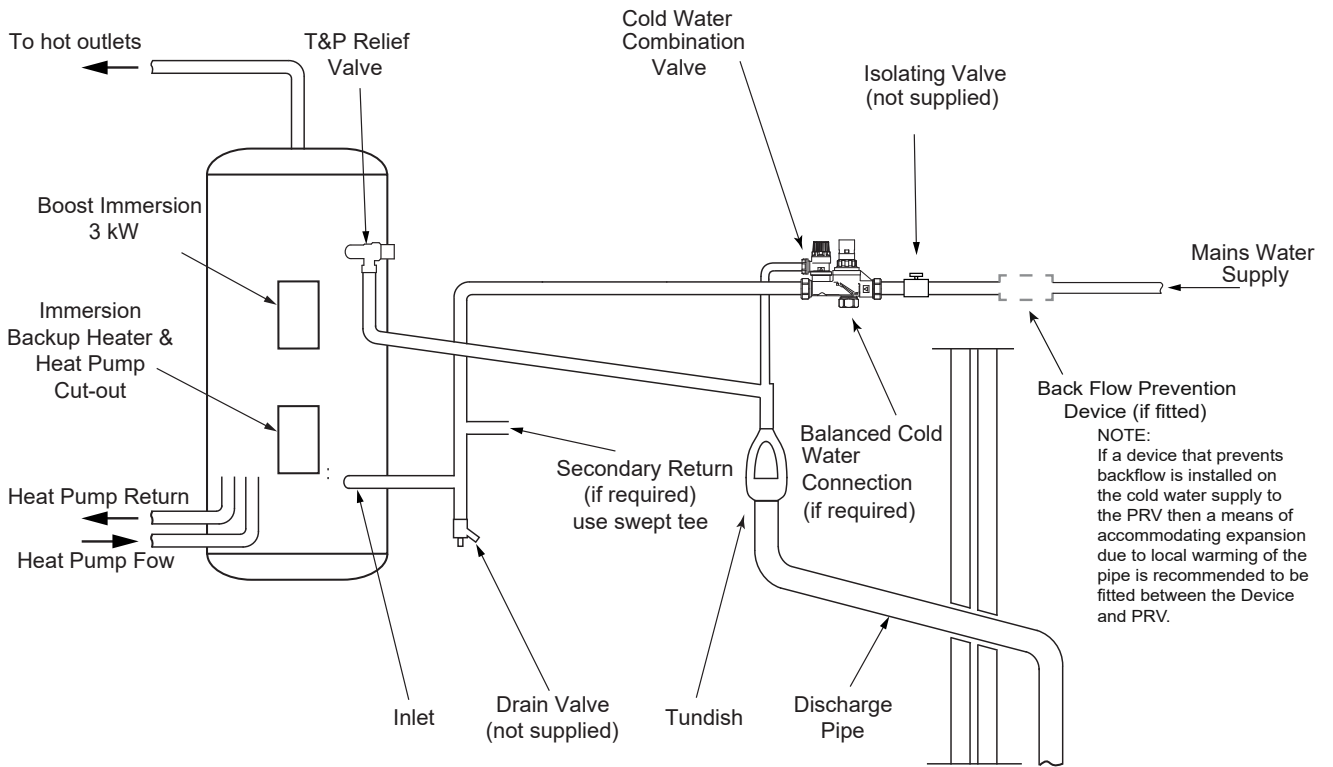

Fig. 4: Typical Discharge Pipe Arrangement (Extract from building regulation G3 guidance section 3.50)



NOTE:
A backflow prevention device may include check valves, a water meter or an additional PRV

Fig. 5: Typical Installation - Schematic

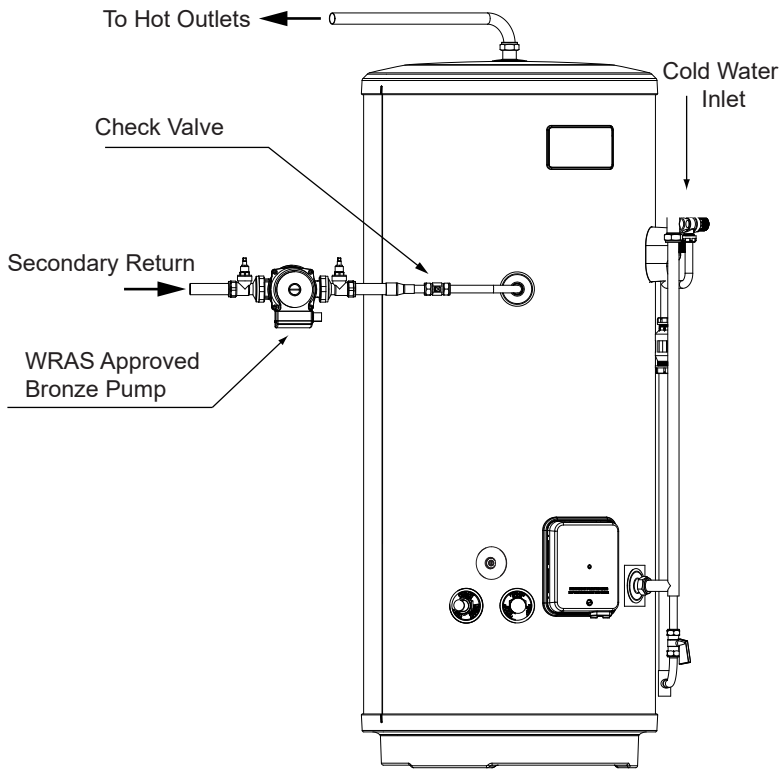

Fig. 6: Secondary Circulation Connection

Installation

When installing with ASHP see Instruction 7841138

Heat Pump Control - see Heat Pump manual

The Heat Pump (HP) should have a thermal control to monitor the temperature in the cylinder. One control is acceptable but two are recommended. Also employ a method to connect to the cylinder so that in the event of the cylinder thermal cut-out being activated the HP and any internal backup heaters/ additional heat sources will shut down.

Safety

DISCONNECT FROM THE MAINS ELECTRICAL SUPPLY BEFORE REMOVING ANY COVERS. Never attempt to replace the immersion heater other than with the authorised spare part.

DO NOT BYPASS THE THERMAL CUT-OUT(S) IN ANY CIRCUMSTANCES. Ensure the two male spade terminations from the dual thermostat and cut-out are pushed firmly onto the corresponding terminations on the immersion heater.

In case of difficulty contact service support - see details on the back page of this manual.

Electrical Supply

All electrical wiring should be carried out by a competent electrician and be in accordance with the latest I.E.E Wiring Regulations.

Each circuit must be protected by a suitable fuse and double pole isolating switch with a contact separation of at least 3 mm in both poles.

The boost immersion heater should be wired in accordance with Fig. 7, opposite. The immersion heater MUST be earthed. The supply cable should be 1.5 mm² 3 core HO5 VV-F sheathed and must be routed through the cable grip provided with the outer sheath of the cable firmly secured by tightening the screws on the cable grip.

DO NOT operate the immersion heaters until the cylinder has been filled with water.

Ensure the thermostat and thermal cut-out sensing bulbs are pushed fully into the pockets on the element plate assembly.

It is recommended that wires are terminated with a bootlace-type ferrule.

Plumbing Connections

ASHP cylinders require the following pipework connections:

- Cold water supply to and from inlet controls.
- Outlet to hot water draw off points.
- Discharge pipework from valve outlets to tundish.
- Connection to the heat pump circuit.

All connections are 22 mm compression. However, 3/4" BSP parallel threaded fittings can be fitted to the primary coil connections if required.

Primary Circuit Control

The 3 port motorised valve supplied with the cylinder MUST be fitted on the primary flow to the cylinder heat exchanger (coil) and wired back to the HP control. Primary circulation to the cylinder heat exchanger (coil) must be pumped; gravity circulation WILL NOT WORK.

Space and Heating Systems Controls

Consult Heat Pump User Instructions on how to set up space heating requirements.

Wiring schematics when installing cylinder without ASHP

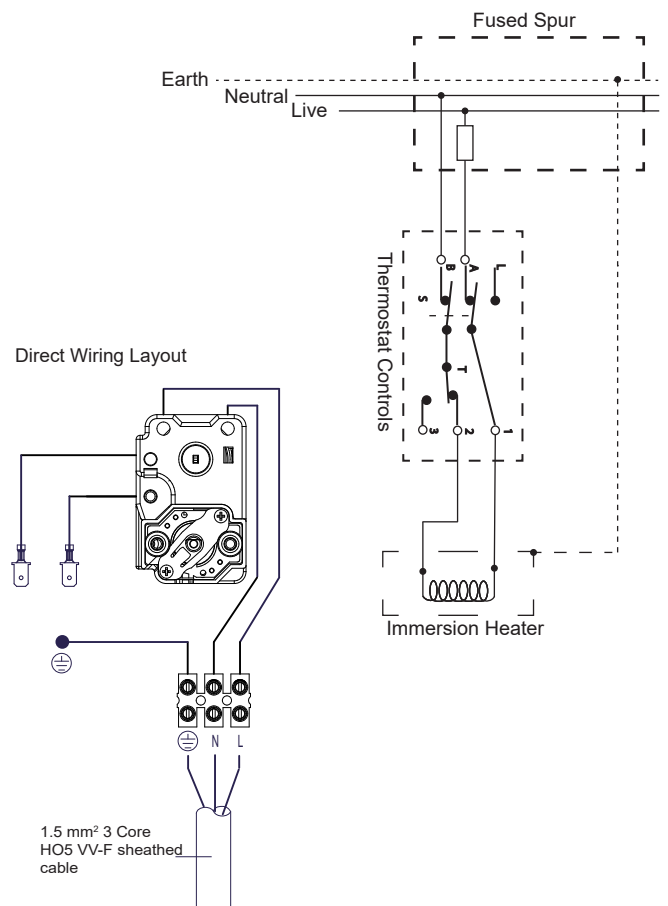

Fig. 7: Wiring Schematics

Commissioning - Cylinder

Filling The Unit With Water

- Check all connections for tightness including the immersion heaters. An immersion heater key spanner is supplied for this purpose.
- Ensure any drain valves are closed.
- Open a hot tap furthest from the cylinder.
- Open the mains stop valve to fill the unit. When water flows from the tap, allow to run for a few minutes to thoroughly flush through any residue, dirt or swarf, then close the tap.
- Open successive hot taps to purge the system of air.

System Checks

- Check all water connections for leaks and rectify as necessary.
- Turn mains water supply off.
- Remove the pressure reducing valve head to access the strainer mesh, clean and re-fit.
- Turn mains water supply on.
- Manually open each relief valve in turn for a few seconds. Check that water is discharged and runs freely through the tundish and out at the discharge point.
- Ensure that the valve(s) re-seat satisfactorily.

Boost Immersion

- Switch on electrical supply to the immersion heater and allow the cylinder to heat up to normal working temperature (60 - 65 °C recommended).
- If necessary the temperature can be adjusted by inserting a flat bladed screwdriver in the adjustment spindle on front of the immersion heater (ELEMENT) control thermostat and rotating (see Fig. 8 below). The adjustment represents a temperature range of 10 to 70 °C.
- Check the operation of thermostat(s) and that no water has discharged from the expansion relief valve or temperature/pressure relief valve during the heating cycle.

Heat Pump Immersion Backup Heater

- The heat pump immersion is controlled by the Heat Pump and should be set to maximum on the thermal controller on the cylinder. See Fig. 8 below for how to set the immersion to it's maximum setting. If this is not done it could impact on the efficiency of the Heat Pump and the temperature of the hot water available.

Benchmark Log Book

On completion of the installation and commissioning procedures detailed in this manual the Benchmark Installation, Commissioning and Service Record Log, pages 22 and 23 should be completed and signed off by the competent installer or commissioning engineer in the relevant sections. The various system features, location of system controls, user instructions and what to do in the event of a system failure should be explained to the customer. The customer should then countersign the Benchmark™ Commissioning Checklist (page 22) to accept completion. The service record should be filled in when any subsequent service or maintenance operation is carried out on the product.

THERMAL CUT-OUT RESET BUTTON

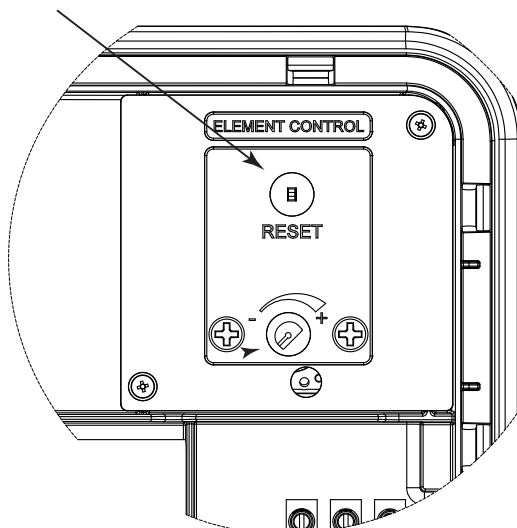

SPINDLE POSITIONS

 = MINIMUM TEMP

 = MAXIMUM TEMP

 = APPROX 60 °C

ROTATE SPINDLE CLOCKWISE
FOR TEMPERATURE INCREASE
AND COUNTER CLOCKWISE
FOR TEMPERATURE DECREASE

Fig. 8: Temperature Adjustment Details

Typical wiring schematic

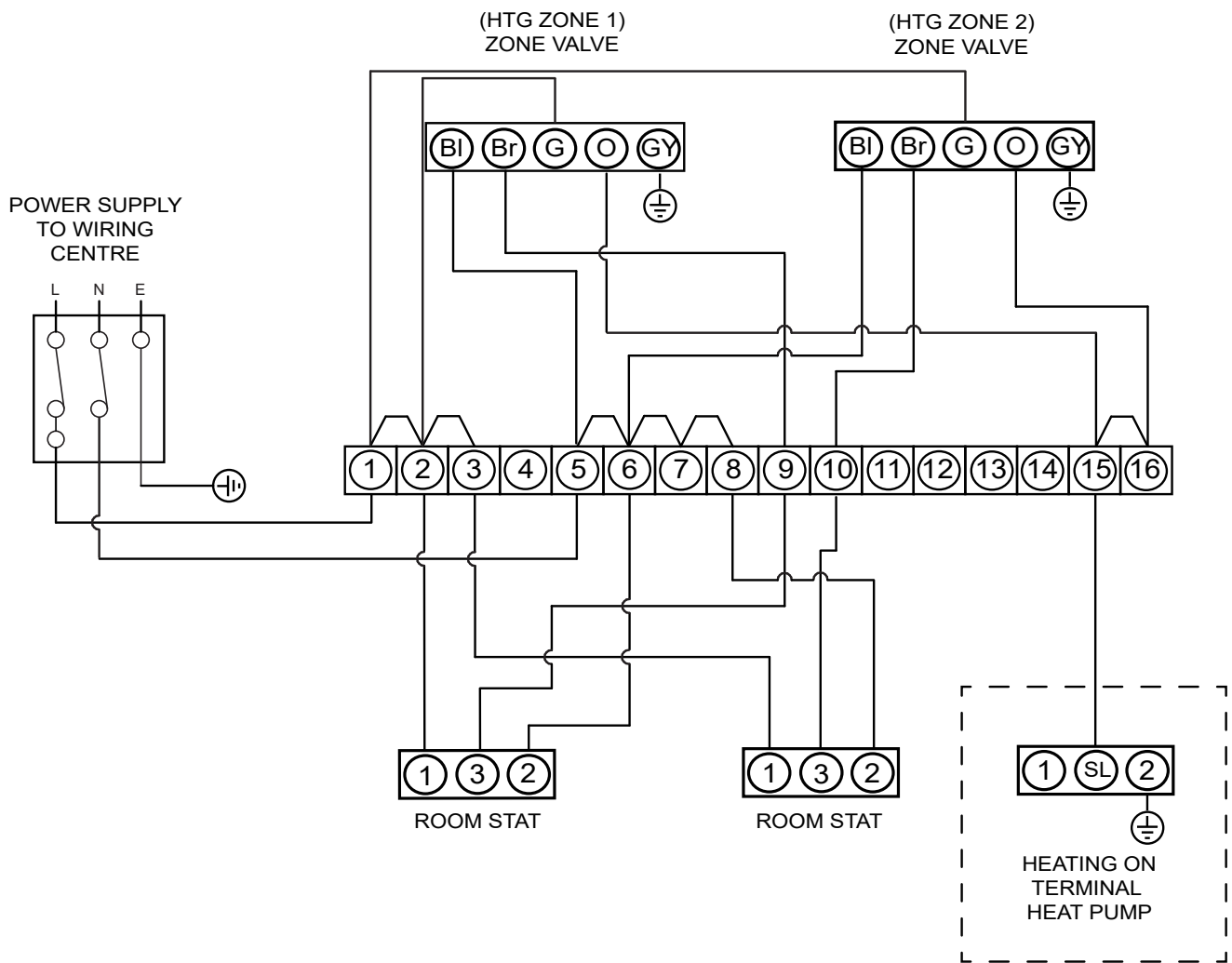

Fig. 9: Typical Wiring Schematic

Maintenance

Maintenance Requirements

Unvented hot water systems have a continuing maintenance requirement in order to ensure safe working and optimum performance. It is essential that the relief valve(s) are periodically inspected and manually opened to ensure no blockage has occurred in the valves or discharge pipework.

Cleaning of the strainer element and replacement of the air in the internal air bubble will help to prevent possible operational faults.

The maintenance checks described below should be performed by a competent person on a regular basis, e.g. annually to coincide with boiler maintenance.

After any maintenance, please complete the relevant Service Interval Record section of the Benchmark Checklist on page 22 of this manual.

Inspection

The lower immersion boss can be used as an access point for inspecting the cylinder internally.

Safety Valve Operation

Manually operate the temperature/pressure relief valve for a few seconds. Check water is discharged and that it flows freely through the tundish and discharge pipework. Check valve re-seats correctly when released.

NOTE: Discharged water may be very hot!

Repeat the above procedure for the expansion relief valve.

Strainer

Turn off the cold water supply, boiler and boost immersion heaters and any additional heat sources. The lowest hot water tap should then be opened to de-pressurise the system. Remove the pressure reducing cartridge to access the strainer mesh. Wash any particulate matter from the strainer under clean running water. Re-assemble ensuring the seal is correctly fitted. DO NOT use any other type of sealant.

De-scaling Immersion Heaters

Before removing the immersion heater the unit must be drained. **Before draining ensure the water, electrical supply and Heat Pump have been hydraulically and electrically isolated.** Attach a hose pipe to the drain valve. The pipe should have sufficient length to drain water to a suitable discharge point below the level of the unit. Open a hot tap close to the unit and open drain valve to drain the cylinder. Remove the cover to the immersion heater housing and disconnect wiring from immersion heater. Carefully remove the thermostat capillaries. Note the order of the capillaries within the pocket.

Undo the back nut with the tools supplied and remove the immersion, taking note of the orientation. Carefully remove any scale from the surface of the element. DO NOT use a sharp implement to remove scale as it may damage the element surface. Ensure sealing surfaces are clean and seals are undamaged. If in doubt fit a new gasket (part number 70 351 68).

Replace immersion heater ensuring the leg is pointing downwards for the lower immersion - it may be helpful to support the immersion heater using a round bladed screwdriver inserted into one of the thermostat pockets whilst the back nut is tightened. Replace thermostat capillaries into pockets. Connect wiring to element. Check, close and secure the immersion heater housing cover.

If necessary the temperature can be adjusted by inserting a flat bladed screwdriver in the adjustment knob on front of the immersion heater thermostat and rotating. The adjustment represents a temperature range of 12 to 72 °C. Check the operation of thermostat(s) and that no water has discharged from the expansion relief valve or temperature/pressure relief valve during the heating cycle.

The same procedure can be used for both the boost immersion and immersion backup heater.

Re-Commissioning

Check all electrical and plumbing connections are secure. Close the drain valve. **DO NOT switch on the immersion heater or Heat Pump while the unit is empty.** With a hot tap open, turn on the cold water supply and allow unit to refill. When water flows from the hot tap allow to continue for a short while to purge air and flush through any disturbed particles. Close hot tap and then open successive hot taps in system to purge any air. When completely full and purged check system for leaks. Replace and secure immersion heater housing cover. The heating source (immersion heater or heat pump) can then be switched on.

Expansion Vessel Charge Pressure

Remove the dust cap on top of the vessel. Check the charge pressure using a tyre pressure gauge. The pressure (system de-pressured) should be equal to or slightly above the incoming mains water pressure, no higher than 0.05 KPa (0.5 bar) above. If it is lower than the required setting it should be re-charged using a tyre pump (Schrader valve type). DO NOT OVER-CHARGE. Re-check the pressure and when correct replace the dust cap.

User Instructions

Warnings

IF WATER DISCHARGES FROM THE CYLINDER TEMPERATURE/PRESSURE RELIEF VALVE SHUT DOWN THE BOILER, HEAT PUMP AND ANY ADDITIONAL HEAT SOURCES. DO NOT TURN OFF ANY WATER SUPPLY. CONTACT A COMPETENT INSTALLER OF UNVENTED WATER HEATERS TO CHECK THE SYSTEM.

DO NOT TAMPER WITH ANY OF THE SAFETY VALVES FITTED TO THE SYSTEM. IF A FAULT IS SUSPECTED CONTACT A COMPETENT INSTALLER.

This product should be serviced annually to optimise its safety, efficiency and performance. The service engineer should complete the relevant Service Record on the Checklist after each service.

The service record may be required in the event of any warranty work.

Flow Performance

When initially opening hot outlets a small surge in flow may be noticed as pressures stabilise. This is quite normal with unvented systems. In some areas cloudiness may be noticed in the hot water. This is due to aeration of the water which is quite normal and will quickly clear.

Boost Immersion Heater

A boost immersion heater is also provided for use should the Heat Pump be shut down for any purpose. The immersion heater control temperature is set using the immersion heater thermostat - see Fig. 8, page 13.

DO NOT bypass the thermal cut-out(s) in any circumstances.

Operational Faults

Operational faults and their possible causes are detailed in the Fault Finding section of this manual. It is recommended that faults should be checked by a competent installer.

The air volume within the expansion vessel will periodically require recharging to ensure any expanded water is accommodated within the unit. A discharge of water INTERMITTENTLY from the pressure relief valve will indicate the air volume has reduced to a point where it can no longer accommodate the expansion.

Fault Finding & Servicing

Important

- After servicing, complete the relevant Service Interval Record section of the Benchmark Checklist located on pages 22 and 23 of this manual.
- Servicing should only be carried out by persons competent in the installation and maintenance of unvented water heating systems.
- Any spare parts used MUST be authorised parts.
- Disconnect the electrical supply before removing any electrical equipment covers.
- NEVER bypass any thermal controls or operate system without the necessary safety valves.
- Water contained in the cylinder may be very hot, especially following a thermal control failure. Caution must be taken when drawing water from the unit.

Fault	Possible cause	Remedy
No water flowing from hot taps	1. Mains water supply off.	1. Check and open mains valve.
	2. Strainer blocked.	2. Turn off water supply. Remove strainer in pressure reducing valve and clean.
	3. Cold water combination valve incorrectly fitted.	3. Check and refit as required.
Water from hot taps is cold	1. Immersion backup heater not switched on.	1. Check and switch on.
	2. Immersion backup heater thermal cut-out has tripped.	2. Check. Reset by pushing button (Figure 08, page 13).
	3. Programmer set to central heating only.	3. Check. Set domestic to a hot water programme. Check DHW delay settings if high DHW demand usage.
	4. Heat Pump not working.	4. Check Heat Pump operation. If fault is suspected consult Heat Pump manufacturers instructions.
	5. Heat Pump thermal cut-out has tripped.	5. Check. Reset by pushing button.
	6. Motorised 3 port valve not connected correctly.	6. Check wiring and/or plumbing connections to motorised valve. See manual 7841138 for information on wiring schematics.
Water discharges from expansion relief valve	1. Intermittently - charge pressure in expansion vessel has reduced or been depleted	1. See page 15 for details on how to test and recharge.
	2. Continually - 3 bar pressure reducing valve is not working correctly.	2. Check pressure from 3 bar pressure reducing valve. If greater than 3 bar replace pressure reducing cartridge.
	3. Continually - expansion valve seat damaged.	3. Remove expansion relief cartridge from 8 bar pressure relief valve and check seating. If necessary fit new cartridge.
Water discharges from the T&P valve intermittently	1. Charge pressure in expansion vessel has reduced or been depleted.	1. See page 15 for details on how to test and recharge.
	2. 8 bar expansion relief valve faulty.	2. Check valve and replace if necessary
Water discharges from the T&P valve continually	1. Thermal control failure. Note: water will be very hot.	1. Switch off power supply to immersion heater(s) and shut down the ASHP. DO NOT turn off the water supply. When discharge stops check all thermal controls, replace if faulty.
Milky water	1. Oxygenated water.	1. Water from a pressurised system releases oxygen bubbles when flowing. The milkiness will disappear after a short while.

Table 5: Fault Finding Chart

Environmental

WEEE Declaration

Disposal of Waste Equipment by Users in Private Household in the European Union.



This symbol on the product indicates that this product must not be disposed of with your other household waste. Instead, it is your responsibility to dispose of your waste equipment by handing it over to a designated collection point for the recycling of waste electrical equipment. The separate collection and recycling of your waste equipment at the time of disposal will help to conserve natural resources and ensure that it is recycled in a manner that protects human health and the environment. For more information about where you can drop off your waste equipment for recycling, please contact your local city office, your household waste disposal service or the company where this product was purchased.

Insulation is by means of an approved CFC/HCFC free polyurethane foam with an ozone depletion factor of zero.

Spares

Spare Parts

A full range of spare parts are available for the cylinder range (Table 6, page 18). Refer to the technical data label on the unit to identify the model installed and ensure the correct part is ordered. You will need to quote the serial number, which is printed on the data label.

Fault Finding

The fault finding chart (Table 5, page 17) will enable operational faults to be identified and their possible causes rectified. Any work carried out on the unvented water heater and its associated controls MUST be carried out by a competent installer of unvented water heating systems. In case of doubt contact customer support (see contact details on back page).

Warning

DO NOT TAMPER WITH ANY OF THE SAFETY VALVES OR CONTROLS SUPPLIED WITH THE CYLINDER AS THIS WILL INVALIDATE ANY GUARANTEE.

Spares

Item Number	Description	Part Number
1	Immersion heater - boost	95 606 986
2	Immersion heater - Heat pump back-up	95 606 984
3	Immersion heater gasket	77 029 35
4	Immersion heater back-nut	95 605132
5	Immersion heater key spanner (not shown)	95 607 861
6	Tundish (not shown)	95 605 838
7	Cold water combination valve complete	70 365 20
8	Nut & olive pack - 4 of each) (not shown)	95 607 838
9	Controls cover	77 454 91
10	Direct combined thermostat and thermal cut-out	95 612 720
11	Direct mounting plate	95 627 929
12	Motorised valve 2 port (not shown)	95 605 049
13	Motorised valve 3 port complete (not shown)	7745493
14	Valve body 28 mm 3 port (not shown)	7763614
15	Actuator head 3 port valve (not shown)	7763613
16	3 way terminal block	95 607113
17	Temperature and pressure relief valve	95 605 810
18	½" BSP sensor pocket long, for systems that use two DHW sensors.	7 032 579
19	Insulation set for T&P valve	95 607922
20	Expansion vessel 24 L (not shown)	95 607 612
21	Expansion Vessel 18 L (not shown)	95 607 864
22	Contactator	7846680
23	Temperature Probe	7750595

Table 6: Spares

Spares

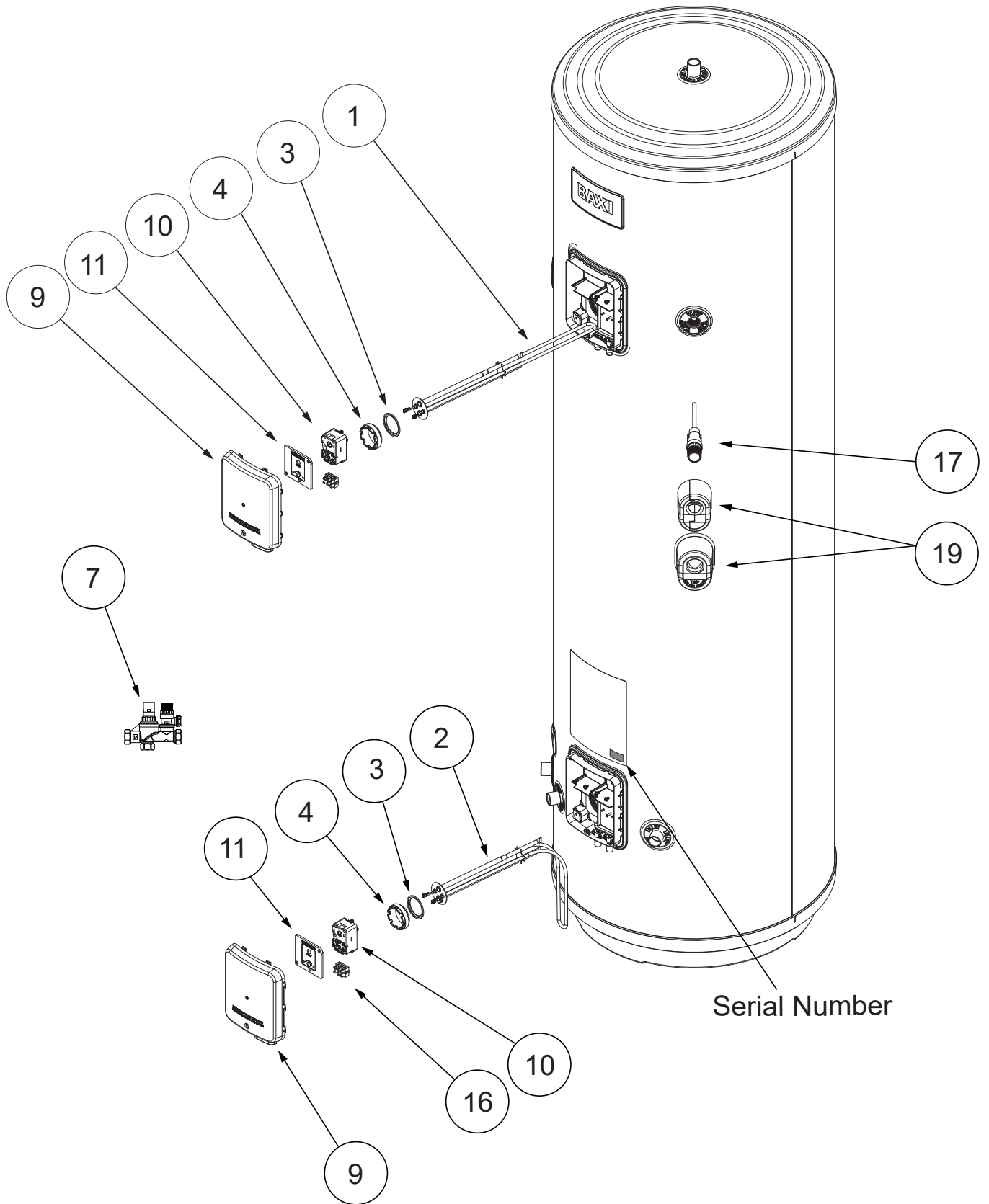

Fig. 10: Spares Schematic 1

Spares

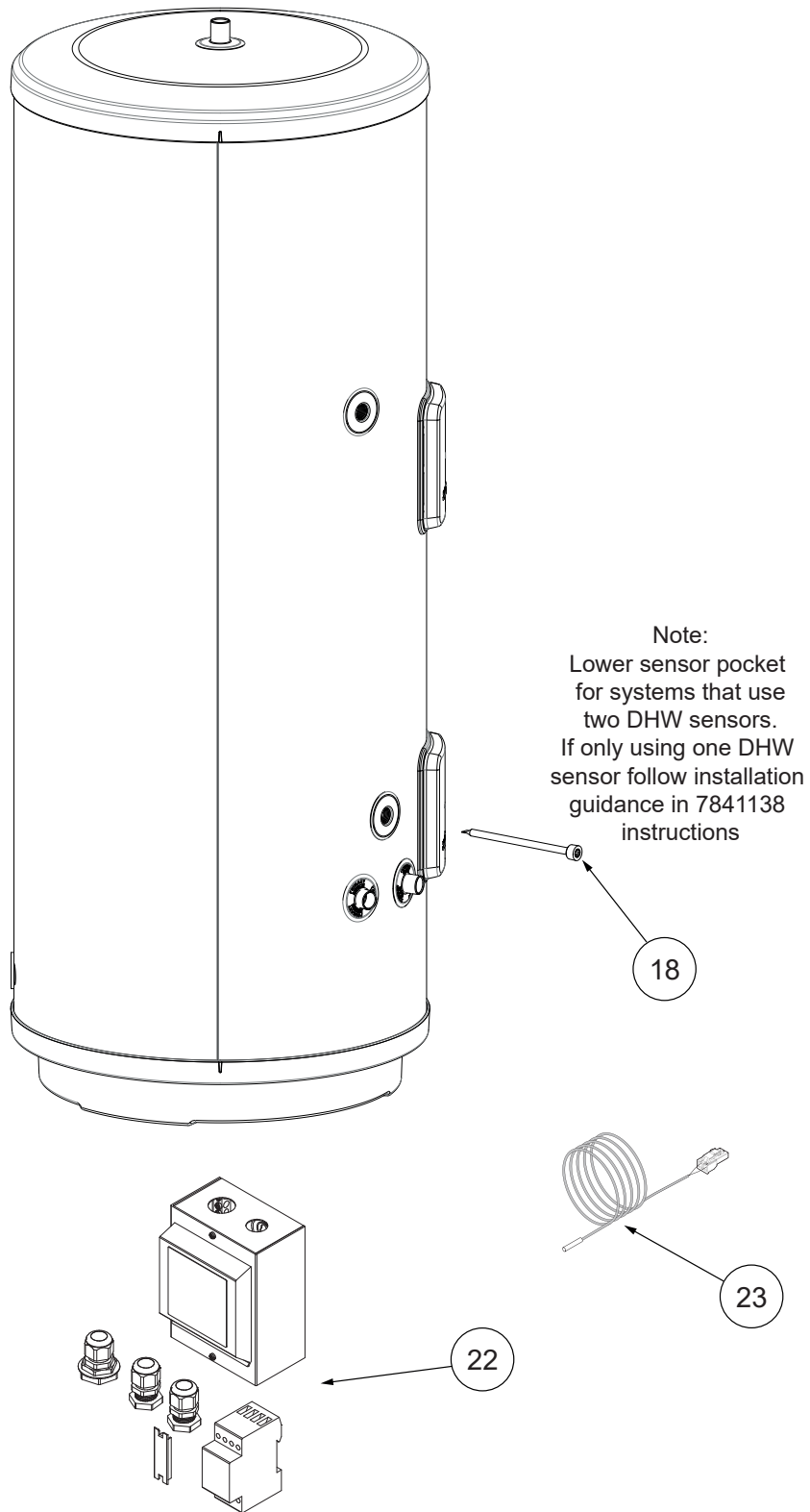

Fig. 11: Spares Schematic 2

MAINS PRESSURE HOT WATER STORAGE SYSTEM COMMISSIONING CHECKLIST

This Commissioning Checklist is to be completed in full by the competent person who commissioned the storage system as a means of demonstrating compliance with the appropriate Building Regulations and then handed to the customer to keep for future reference.

Failure to install and commission this equipment to the manufacturer's instructions may invalidate the warranty but does not affect statutory rights.

Customer Name _____ Telephone Number _____
 Address _____
 Cylinder Make and Model _____
 Cylinder Serial Number _____
 Commissioned by (*print name*) _____ Registered Operative ID Number _____
 Company Name _____ Telephone Number _____
 Company Address _____
 _____ Commissioning Date _____

To be completed by the customer on receipt of a Building Regulations Compliance Certificate*:

Building Regulations Notification Number (*if applicable*) _____

ALL SYSTEMS PRIMARY SETTINGS (indirect heating only)

Is the primary circuit a sealed or open vented system? Sealed Open
 What is the maximum primary flow temperature? _____ °C

ALL SYSTEMS

What is the incoming static cold water pressure at the inlet to the system? _____ bar
 Has a strainer been cleaned of installation debris (if fitted)? Yes No
 Is the installation in a hard water area (above 200ppm)? Yes No
 If yes, has a water scale reducer been fitted? Yes No
 What type of scale reducer has been fitted? _____
 What is the hot water thermostat set temperature? _____ °C
 What is the maximum hot water flow rate at set thermostat temperature (measured at high flow outlet)? _____ l/min
 Time and temperature controls have been fitted in compliance with Part L of the Building Regulations? Yes
 Type of control system (if applicable) Y Plan S Plan Other
 Is the cylinder solar (or other renewable) compatible? Yes No
 What is the hot water temperature at the nearest outlet? _____ °C
 All appropriate pipes have been insulated up to 1 metre or the point where they become concealed Yes

UNVENTED SYSTEMS ONLY

Where is the pressure reducing valve situated (if fitted)? _____
 What is the pressure reducing valve setting? _____ bar
 Has a combined temperature and pressure relief valve and expansion valve been fitted and discharge tested? Yes No
 The tundish and discharge pipework have been connected and terminated to Part G of the Building Regulations Yes
 Are all energy sources fitted with a cut out device? Yes No
 Has the expansion vessel or internal air space been checked? Yes No

THERMAL STORES ONLY

What store temperature is achievable? _____ °C
 What is the maximum hot water temperature? _____ °C

ALL INSTALLATIONS

The hot water system complies with the appropriate Building Regulations Yes
 The system has been installed and commissioned in accordance with the manufacturer's instructions Yes
 The system controls have been demonstrated to and understood by the customer Yes
 The manufacturer's literature, including Benchmark Checklist and Service Record, has been explained and left with the customer Yes

Commissioning Engineer's Signature _____

Customer's Signature _____
 (*To confirm satisfactory demonstration and receipt of manufacturer's literature*)

SERVICE RECORD

It is recommended that your hot water system is serviced regularly and that the appropriate Service Record is completed.

Service Provider

Before completing the appropriate Service Record below, please ensure you have carried out the service as described in the manufacturer's instructions.

SERVICE 1 Date _____ Engineer Name _____ Company Name _____ Telephone Number _____ Comments _____ _____ _____ Signature _____

SERVICE 2 Date _____ Engineer Name _____ Company Name _____ Telephone Number _____ Comments _____ _____ _____ Signature _____

SERVICE 3 Date _____ Engineer Name _____ Company Name _____ Telephone Number _____ Comments _____ _____ _____ Signature _____

SERVICE 4 Date _____ Engineer Name _____ Company Name _____ Telephone Number _____ Comments _____ _____ _____ Signature _____

SERVICE 5 Date _____ Engineer Name _____ Company Name _____ Telephone Number _____ Comments _____ _____ _____ Signature _____

SERVICE 6 Date _____ Engineer Name _____ Company Name _____ Telephone Number _____ Comments _____ _____ _____ Signature _____

SERVICE 7 Date _____ Engineer Name _____ Company Name _____ Telephone Number _____ Comments _____ _____ _____ Signature _____

SERVICE 8 Date _____ Engineer Name _____ Company Name _____ Telephone Number _____ Comments _____ _____ _____ Signature _____

SERVICE 9 Date _____ Engineer Name _____ Company Name _____ Telephone Number _____ Comments _____ _____ _____ Signature _____

SERVICE 10 Date _____ Engineer Name _____ Company Name _____ Telephone Number _____ Comments _____ _____ _____ Signature _____
--

FOR UNITED KINGDOM

For Baxi Customer Support and Technical Advice, contact us at



0344 871 1545

Opening hours

Monday - Friday, 8.00am-6.00pm

Weekends & Bank Holidays, 8.30am-2.00pm

Please note calls may be recorded for training and monitoring purposes



baxi.co.uk



Baxi
Brooks House,
Coventry Road,
Warwick, CV34 4LL

FOR IRELAND

For Baxi Potterton Myson Customer Support and Technical Advice, contact us at



00353 (0)1 4590870

Opening hours

Monday - Thursday, 8.00am-4.30pm, Friday, 8.00am-4.00pm

In-Warranty cover on Saturdays: 9am - 12pm October - March

We are closed on Bank Holidays, Christmas Day and New Year's Day.

Please note calls may be recorded for training and monitoring purposes



www.baxipottertonmyson.ie



Baxi Potterton Myson
Unit F 5&6, Calmount Park,
Calmount Road,
Ballymount ,
Dublin 12, Ireland

The policy of Baxi Heating UK is one of continuous product development and, as such, we reserve the right to change specifications and guarantee terms and conditions without notice.