

## User Guide

### High Efficiency Wall Hung Condensing Gas Boiler

**Baxi System**  
818 - 824

Please keep these instructions in a safe place.  
If you move house please hand them over to the next occupier.

**Dear Customer,**

Thank you very much for buying this appliance.

Please read through the manual carefully before using the product, and keep it in a safe place for later reference. In order to ensure continued safe and efficient operation we recommend that the product is serviced regularly. Our service and customer service organisation can assist with this.

We hope you enjoy years of problem-free operation with the product.

# Contents

<b>1</b>	<b>Safety</b>	<b>5</b>
1.1	General safety instructions	5
1.2	Recommendations	6
1.2.1	The Benchmark Scheme	6
1.2.2	Benchmark Commissioning Checklist	6
1.3	Liabilities	6
1.3.1	User's liability	6
1.3.2	Installer's liability	7
1.3.3	Manufacturer's liability	7
<b>2</b>	<b>About this manual</b>	<b>8</b>
2.1	General	8
2.2	Additional documentation	8
2.3	Symbols used	8
2.3.1	Symbols used in the manual	8
2.4	Abbreviations/glossary	8
<b>3</b>	<b>Technical specifications</b>	<b>10</b>
3.1	Homologations	10
3.1.1	Certifications	10
3.2	Technical data	10
3.2.1	Technical information	10
3.2.2	Dimensions and connections/clearances	11
<b>4</b>	<b>Description of the product</b>	<b>12</b>
4.1	General description	12
4.2	Operating principle	12
4.2.1	In operation	12
4.3	Control panel description	12
4.3.1	Description of the control panel	12
4.4	Accessories and options	13
4.4.1	Optional accessories	13
<b>5</b>	<b>Operation</b>	<b>14</b>
5.1	Start-up	14
5.1.1	Operation checking procedure & basic fault identification	14
5.2	Use of the control panel	16
5.2.1	Using the control panel	16
5.3	Shutdown	16
5.4	Frost protection	16
<b>6</b>	<b>Maintenance</b>	<b>17</b>
6.1	General	17
6.2	Maintenance instructions	17
6.2.1	Re-pressurising the system	17
6.3	Venting the installation	19
6.4	Draining the installation	20
<b>7</b>	<b>Troubleshooting</b>	<b>21</b>
7.1	Error codes	21
7.1.1	List of error codes	21
7.2	Fault finding	22
<b>8</b>	<b>Decommissioning</b>	<b>23</b>
8.1	Decommissioning procedure	23
<b>9</b>	<b>Disposal</b>	<b>24</b>
9.1	Disposal and recycling	24
<b>10</b>	<b>Environmental</b>	<b>25</b>
10.1	Energy saving	25
10.2	Room thermostats and settings	25
<b>11</b>	<b>Warranty</b>	<b>26</b>

Contents

11.1	General .....	26
11.2	Standard warranty terms and conditions .....	26
<b>12</b>	<b>Appendix .....</b>	<b>28</b>
12.1	Product fiche - Boiler space heaters .....	28
12.2	Package fiche - boilers .....	29

# 1 Safety

## 1.1 General safety instructions



### Danger

This boiler can be used by children aged 8 years and above and by persons with reduced physical, sensory or mental capabilities or lack of experience and knowledge when they have been given supervision or instruction concerning the safe use of the device and understand the resulting risks. Children must not be allowed to play with the appliance. Cleaning and user maintenance must not be carried out by children without supervision.



### Danger

If you smell gas:

1. Turn off the gas supply at the meter.
2. Open windows and doors in the hazardous area.
3. Do not operate light switches.
4. Do not operate any electrical equipment.
5. Do not use a telephone in the hazardous area.
6. Extinguish any naked flame and do not smoke.
7. Warn any other occupants and vacate the premises.
8. Telephone the National Gas Emergency Service on:- 0800 111 999.

Fig.1 Taps ON and OFF

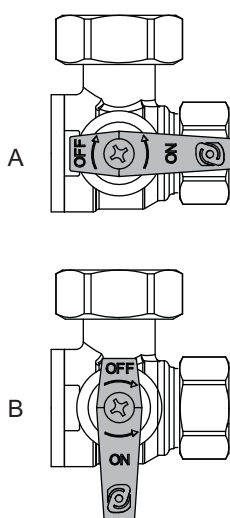

PN-0000367



### Important

If a water or gas leak occurs or is suspected, the boiler can be isolated at the inlet valves by turning their taps through 90° (1/4 turn) downwards.

- |   |     |
|---|-----|
| A | ON  |
| B | OFF |

For advice please contact your Installer, Annual Service Provider or **Baxi Customer Support** - The Service Division of Baxi. You can contact **Baxi Customer Support** on telephone number **0344 871 1545**.

When contacting **Baxi Customer Support** it will be useful to have the "**Benchmark Checklist**" at the back of the Installation & Service Manual to hand as it includes details relevant to the boiler and installation.



### Warning

Do not touch flue/chimney pipes. Depending on the settings of the appliance, the temperature of flue/chimney pipes may exceed 60 °C.

Do not touch radiators for long periods. Depending on the settings of the appliance, the temperature of radiators may reach 85 °C. Take precautions with domestic hot water. Depending on the settings of the appliance, domestic hot water temperature may reach 65 °C.



### Caution

Do not neglect to service the appliance. Contact a qualified professional or take out a maintenance contract for the annual servicing of the appliance.

## 1.2 Recommendations

---



### Caution

- Only qualified professionals are authorised to work on the boiler and the installation.
- The appliance has an integral frost protection mode as long as there is power to the boiler.



### Important

- Regularly check the water pressure in the system (recommended pressure is 1.5 bar).
- Keep the appliance accessible at all times.
- Do not remove or cover the user information and serial number labels affixed to the boiler control flap. They must remain legible throughout the lifetime of the boiler.

### 1.2.1 The Benchmark Scheme

---

Baxi Heating UK Ltd is a licensed member of the Benchmark Scheme which aims to improve the standards of installation and commissioning of domestic heating and hot water systems in the UK and to encourage regular servicing to optimise safety, efficiency and performance.

Benchmark is managed and promoted by Heating and Hotwater Industry Council. For more information visit [www.centralheating.co.uk](http://www.centralheating.co.uk)

### 1.2.2 Benchmark Commissioning Checklist

---

Please ensure that the installer has fully completed the Benchmark Checklist on the inside back pages of the installation instructions supplied with the product and that you have signed it to say that you have received a full and clear explanation of its operation. The installer is legally required to complete a commissioning checklist as a means of complying with the appropriate Building Regulations (England and Wales).

All installations must be notified, by the installer, to Local Area Building Control either directly or through a Competent Persons Scheme. A Building Regulations Compliance Certificate will then be issued to the customer who should, on receipt, write the Notification Number on the Benchmark Checklist.

This product should be serviced annually to optimise its safety, efficiency and performance. The service engineer should complete the relevant section of the Benchmark Service Record in the Installation & Service manual after each service.

The completed Benchmark Checklist & proof of annual servicing (where applicable) will be required in the event of any warranty work.

## 1.3 Liabilities

---

### 1.3.1 User's liability

---

To guarantee optimum operation of the system, you must abide by the following instructions:

- Read and follow the instructions given in the manuals provided with the appliance.
- Call on a qualified professional to carry out installation and initial commissioning.
- Get your installer to explain your installation to you.
- Have the required inspections and maintenance carried out by a qualified installer.
- Keep the instruction manuals in good condition close to the appliance.

### 1.3.2 Installer's liability

---

The installer is responsible for the installation and initial commissioning of the appliance. The installer must observe the following instructions:

- Read and follow the instructions given in the manuals provided with the appliance.
- Install the appliance in compliance with prevailing legislation and standards.
- Carry out initial commissioning and any checks necessary.
- Explain the installation to the user.
- If maintenance is necessary, warn the user of the obligation to check the appliance and keep it in good working order.
- Give all the instruction manuals to the user.

### 1.3.3 Manufacturer's liability

---

Our products are manufactured in compliance with the requirements of all applicable Directives and Regulations. They are therefore delivered with the **CE** marking and any documents necessary. In the interests of the quality of our products, we strive constantly to improve them. We therefore reserve the right to modify the specifications given in this document.

Our liability as manufacturer may not be invoked in the following cases:

- Failure to abide by the instructions on installing the appliance.
- Failure to abide by the instructions on using the appliance.
- Faulty or insufficient maintenance of the appliance.

## 2 About this manual

### 2.1 General

---



#### Warning

Installation, repair and maintenance must only be carried out only by a competent person.

All Gas Safe registered engineers carry an ID card with their licence number and a photograph. You can check your engineer is registered by telephoning 0800 408 5500 or online at [www.gassaferegister.co.uk](http://www.gassaferegister.co.uk)

This manual is intended for the user of the Potterton Assure System boiler. If the appliance is sold or transferred, or if the owner moves leaving the appliance behind you should ensure that the manual is kept with the appliance for consultation by the new owner and their installer.

The appliance is designed as a boiler for use in residential domestic environments on a governed meter supply only. The selection of this boiler is entirely at the owner's risk. If the appliance is used for purposes other than or in excess of these specifications, the manufacturer will not accept any liability for resulting loss, damage or injury.

**The manufacturer will not accept any liability whatsoever for loss, damage or injury arising as a result of failure to observe the instructions for use, maintenance and installation of the appliance.**

### 2.2 Additional documentation

---

Various timers, external controls, etc. are available as optional extras. Full details are contained in the relevant sales literature.

### 2.3 Symbols used

---

#### 2.3.1 Symbols used in the manual

---

This manual uses various danger levels to draw attention to special instructions. We do this to improve user safety, to prevent problems and to guarantee correct operation of the appliance.



#### Danger

Risk of dangerous situations that may result in serious personal injury.



#### Danger of electric shock

Risk of electric shock.



#### Warning

Risk of dangerous situations that may result in minor personal injury.



#### Caution

Risk of material damage.



#### Important

Please note: important information.



#### See

Reference to other manuals or pages in this manual.

### 2.4 Abbreviations/glossary

---

CH Central heating



<b>DHW</b>	Domestic hot water
<b>PCU</b>	PCB for managing burner operation
<b>Pnc</b>	Condensing output
<b>SU</b>	Safety PCB

## 3 Technical specifications

### 3.1 Homologations

#### 3.1.1 Certifications

Tab.1 Certifications

CE certificate number	0085CS0215
NOx class	6
Boiler type	C <sub>13</sub> , C <sub>33</sub>

### 3.2 Technical data

#### 3.2.1 Technical information

Tab.2 General

Baxi System		818	824
Gas council numbers		41 470 73	41 470 74

Tab.3 Central heating circuit specifications

Baxi System		All models
Maximum pressure	bar	3
Minimum pressure	bar	0.5
Central heating temperature adjustment	°C	25/80 ± 5°

Tab.4 Electrical specifications

Baxi System		All models
Nominal electrical power supply voltage	V	230
Nominal electrical power supply frequency	Hz	50
Nominal power consumption when firing	W	100
External fuse rating	Amp	3

Tab.5 Other specifications

Baxi System		All models
Degree of protection against humidity (EN 60529)	IP	IPX5D
Boiler lift weight (dry)	kg	28.1
Dimensions (height/width/depth)	mm	H 700/W 390/D 285
Clearances (above/below casing)	mm	178 / 150 minimum, 200 recommended
front (for servicing)/(in operation)	mm	450 / 5
side (left hand/right hand)	mm	5 / 5
These are MINIMUM recommended dimensions. Greater clearance will aid installation and maintenance.		



#### Important

All data in this section are nominal values and subject to normal production tolerances.

### 3.2.2 Dimensions and connections/clearances

Fig.2 Dimensions and connections / clearances

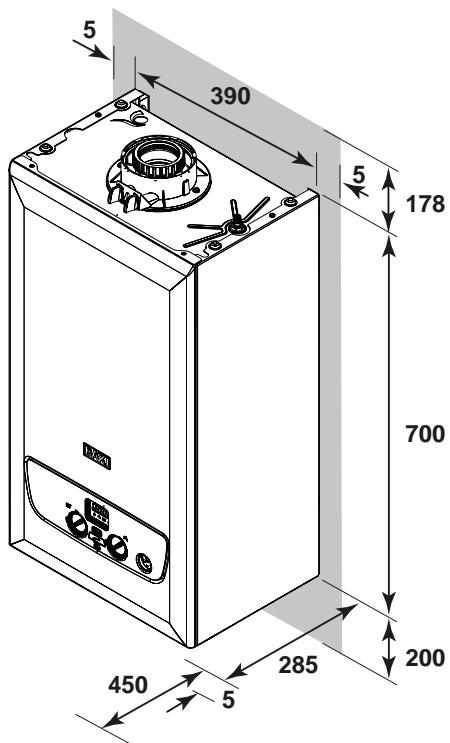

The clearances shown in the diagram are minimum requirements to allow for case removal, spanner access and air movement. These should be observed at all times and kept clear of obstructions.

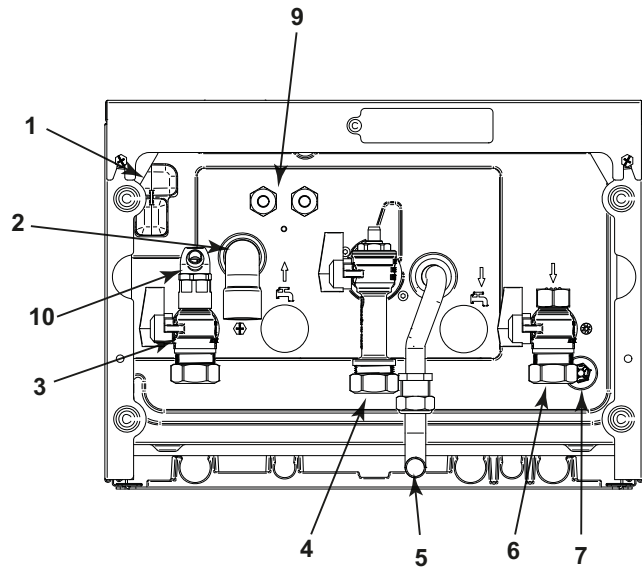

PN-0000624

- 1 Condensate trap sump
- 2 Condensate drain
- 3 Heating circuit water flow
- 4 Gas inlet
- 5 Pressure relief pipe
- 6 Heating circuit water return
- 7 Pump drain point
- 9 Cable entry points
- 10 Boiler drain point on flow isolation tap

## 4 Description of the product

### 4.1 General description

Fig.3 Information label

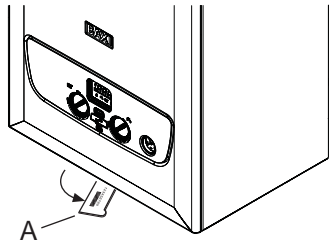

PN-0000368

The Potterton Assure System range of fully automatic gas fired wall hung condensing combination boilers are room sealed and fan assisted, and will serve central heating and mains fed domestic hot water.

A Information label

Tab.6 The boiler is set to give a maximum output of :-

18 model	18 kW 19.4 kW CH Pnc (Condensing)
24 model	24 kW 25.8 kW CH Pnc (Condensing)

The boiler is factory set for use only on Natural Gas (G20).

The boiler model, serial number and Gas Council number are also shown on the information label. This is for user reference.

### 4.2 Operating principle

#### 4.2.1 In operation

Whilst the boiler is in operation cooled flue gases are discharged through the flue gas discharge pipe. This may appear as a cloud of steam which is normal.

Condensed water is discharged from the boiler heat exchanger into a pipe (the condensate drain). This pipe must never be altered or re-routed except by a qualified professional.

### 4.3 Control panel description

Fig.4 Control panel

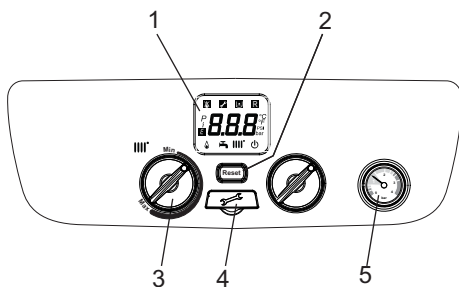

PN-0000335

#### 4.3.1 Description of the control panel

- 1 Display
- 2 Reset button
- 3 Central heating temperature control
- 4 Service diagnostic port
- 5 System water pressure gauge

Fig.5 Display screen

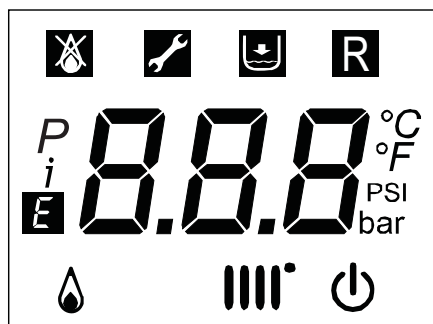

PN-0000337

### Display description

The following symbols may be seen on the display

	OFF (frost protection still enabled)
	Indicates errors that prevent the burner from starting
	Error — not resettable by user
	Water pressure too low
	Indicates a resettable error
<i>P</i>	Not applicable
<i>i</i>	Not applicable
	Generic error
	Burner lit
	Heating mode
<i>°C</i>	Units for temperature
<i>°F</i>	Units for temperature
<i>PSI</i>	Units for pressure
<i>bar</i>	Units for pressure

## 4.4 Accessories and options

### 4.4.1 Optional accessories

The table shows the accessories available for this boiler range.

Tab.7 Optional accessories

Part number	Accessory
7211473	EP2 programmer
7212443	Twin channel timer wired
720971601	Wired room thermostat
720648301	Multifit condensate & PRV combined pump
720644401	Multifit 1m condensate drain pipe 'trace heating' element
720664101	Multifit 2m Condensate drain pipe 'trace heating' element
720664201	Multifit 3m condensate drain pipe 'trace Heating' element
720664401	Multifit 5m condensate drain pipe 'trace heating' element
5121379	Multifit remote secondary PRV kit
7683087	Multifit wired outdoor sensor (System version)
7729979	Multifit IFOS in flue outdoor sensor (System version)

For flue accessories (elbows, extensions, clamps etc.) refer to the Flue Accessories Fitting Guide supplied in the literature pack.

Any of the above **MUST** be fitted **ONLY** by a qualified competent person. Further details can be found in the relevant sales literature and at [www.baxi.co.uk](http://www.baxi.co.uk)

# 5 Operation

## 5.1 Start-up

### 5.1.1 Operation checking procedure & basic fault identification

Fig.6 Start-up and checking

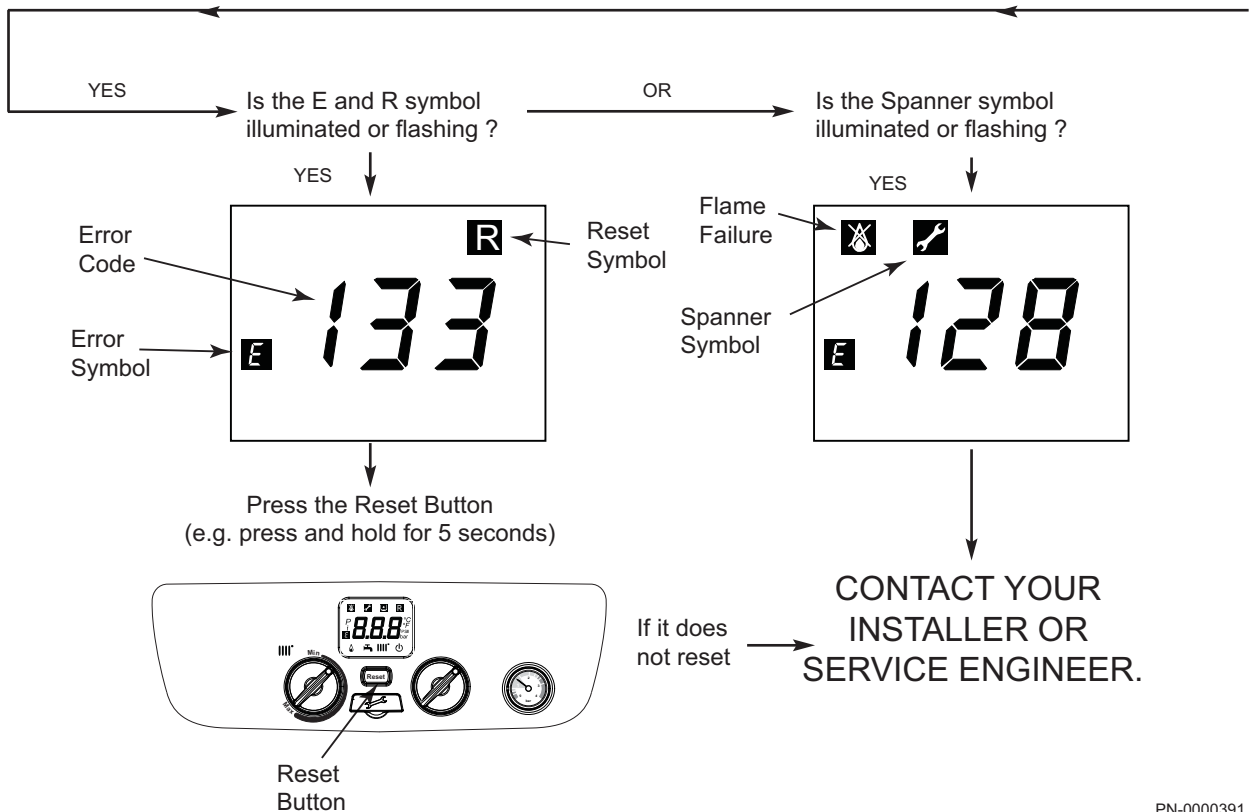
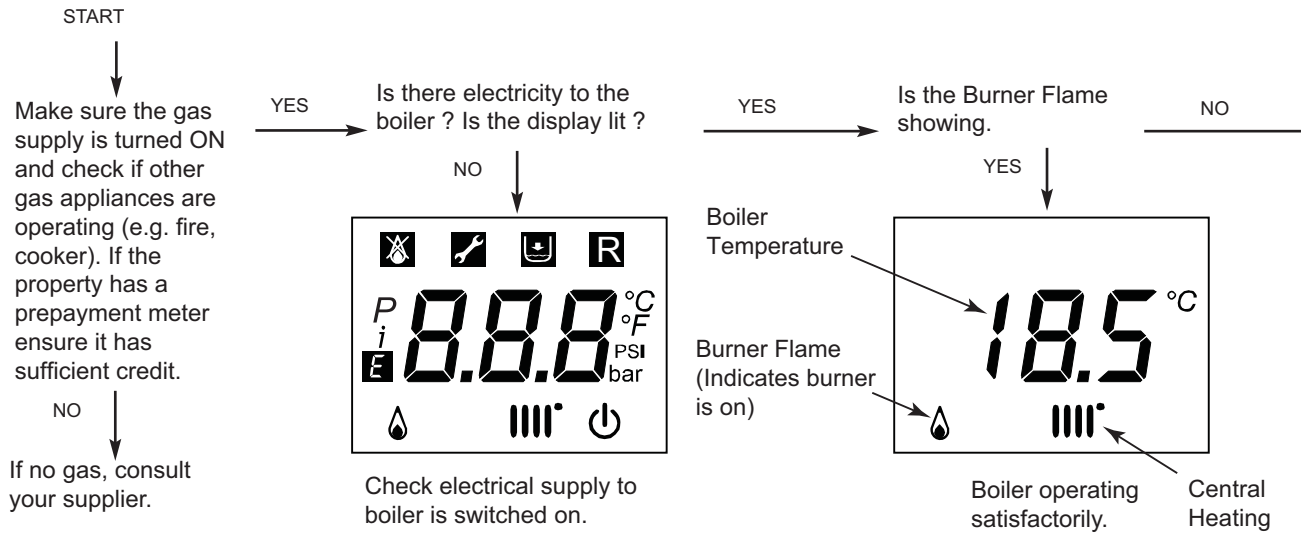
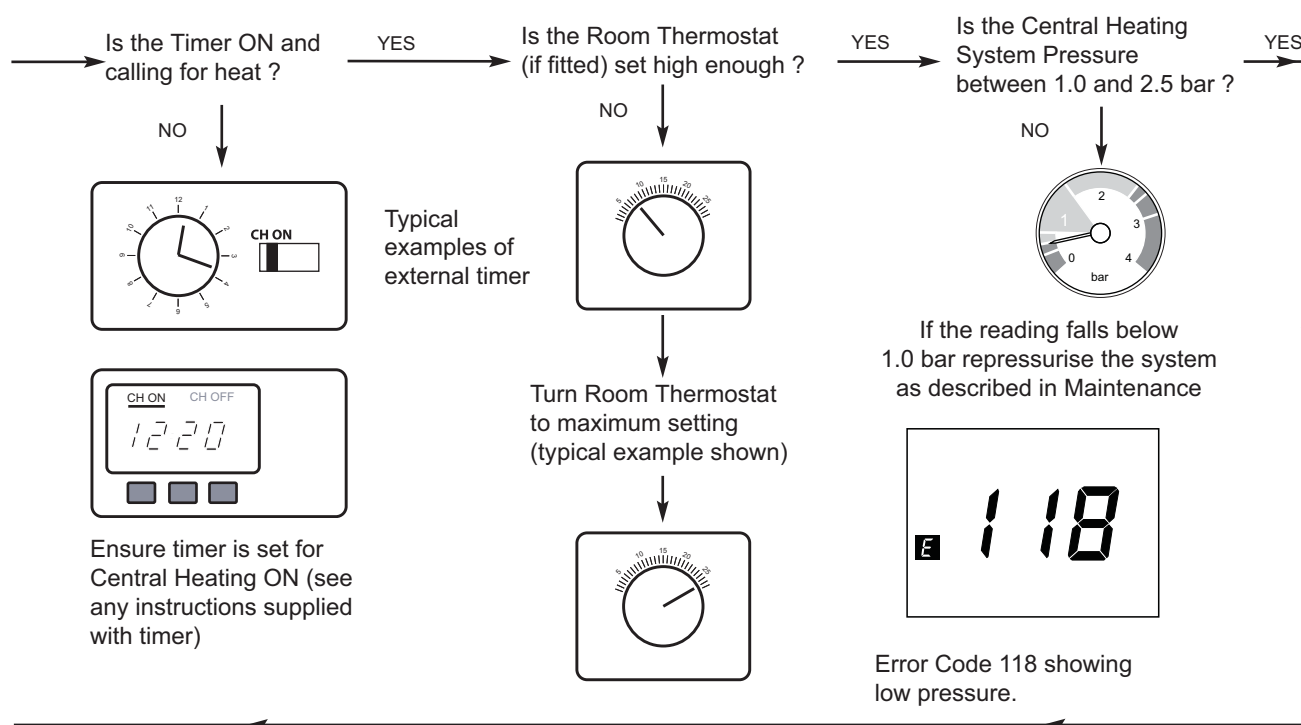

Fig.7 Start-up and checking (continued)



**IMPORTANT:** Where Low Flow Taps or Fittings are intended to be used in the DHW system connected it is strongly recommended that the DHW flow rate DOES NOT fall below 2.5 l/min. This will ensure reliable operation of the DHW function.

If you don't know what you need to do to get the boiler to light, or need help with the system and controls, contact your installer as soon as possible

## 5.2 Use of the control panel

Fig.8 Using the control panel

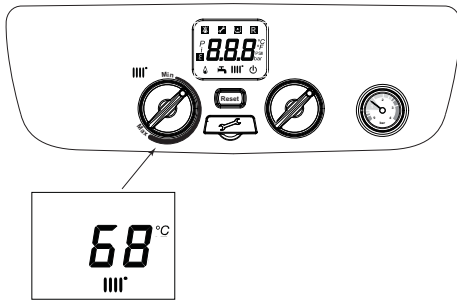

PN-0000372

### 5.2.1 Using the control panel

**Important**  
**OpenTherm controller.** Your installer will advise you when this type of control is connected to the boiler. If so, any change to the boiler settings (e.g. heating temperature) must be made using the OpenTherm controller not the boiler control panel. Please consult the user manual for the OpenTherm controller.

To increase or decrease the boiler temperature:

1. Turn the control knob with the symbol III over it clockwise to increase the boiler set temperature. The set temperature will be shown on the display screen.
2. Turn the control knob with the symbol III over it anticlockwise to decrease the boiler temperature. The temperature will be shown on the display screen.

To reset the boiler:

1. Press the **Reset** button for approximately 1 second, holding the button for more than 2 seconds the boiler will not reset. (see List of error codes, page 21.)

## 5.3 Shutdown

- Isolate the mains power supply at the fused spur unit.
- Isolate the gas supply at the boiler valve.
- Protect the boiler from frost.

**Important**  
 The boiler is not protected against frost once it has been shut down.

**Important**  
 If it is anticipated that the boiler will not be used for a long period or the property is to be unoccupied, it is advised to drain the system if the electricity and gas supplies are to be turned off. Your installer will be able to offer advice.

## 5.4 Frost protection

Where possible, draining the system should be avoided. If the system is to be unused during winter months several precautions must be taken:

- Any parts of the system that are in unheated areas of the dwelling should be fitted with a device such as a pipe thermostat or frost thermostat.
- Power must remain supplied to the boiler and controls.
- Gas must remain supplied to the boiler.

The boiler pump will operate if the system temperature drops below 7°C. If the temperature falls to 4°C the burner will ignite and remain lit until the temperature reaches 10°C. At this temperature the burner will extinguish but the pump will continue to operate for 15 minutes. This feature will protect the boiler and to some extent adjacent parts of the system but additional devices must be incorporated to guarantee frost protection.



## 6 Maintenance

### 6.1 General

---

The boiler does not require any special maintenance. However, the boiler and filter must be serviced annually in accordance with the Installation and Service Manual and the relevant section of the Benchmark Service Record completed in order to maintain the warranty.



#### Important

Taking out a maintenance contract is recommended.



#### Caution

Maintenance operations must be performed by a qualified competent person.

Use only Potterton genuine spare parts.

The painted panels should be wiped with a damp cloth and then dried completely. **DO NOT USE ABRASIVE CLEANING AGENTS.**

### 6.2 Maintenance instructions

---

The central heating system should be checked regularly. Proceed as follows:

1. Check the water pressure in the central heating system.



#### Important

If the water pressure is lower than 0.7 bar, the system must be topped up.



#### See

Re-pressurising the system.



#### Important

If the water pressure drops below 0.5 bar the boiler will not work.

2. Check radiators for leaks and (especially in damp areas) for rust.
3. Open and close the radiator valves several times a year to ensure they can still be rotated.



#### Caution

Only a qualified installer may clean the inside of the boiler.

#### 6.2.1 Re-pressurising the system

---

If the water pressure is too low, the system must be re-pressurised.

The normal operating water pressure is between 1 and 2 bar. If the pressure exceeds 3 bar the safety pressure valve will operate and a fault is indicated. Ensure that the filling loop is disconnected if it is of a temporary type. Contact your installer.

Fig.9 Water pressure

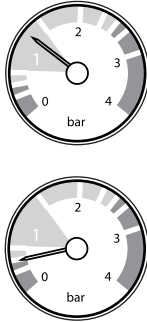

PN-0000641

It may be necessary to repressurise the system occasionally (when the water pressure falls below 0.7). A filling device (the filling loop) will be fitted on the system. This may be on the boiler itself, or on pipework near to the boiler.

**Important**  
 If the water pressure requires regular re-pressurising a fault or leak is indicated. Seek advice from your installer.

Depending on which filling loop is fitted, a temporary filling loop consists of two isolating taps and a separate filling pipe with connection fittings.

Only when repressurising should the filling pipe be connected between the two taps. Ensure that the nuts on the pipe ends are tightened onto the taps.

1. Fully open one of the taps first, and then while watching the pressure gauge, carefully open the second tap.

**Important**  
 The system pressure is shown at all times on the pressure gauge and can be viewed on the display when there is power to the boiler.

2. When the figures on the display or needle on the pressure gauge indicate between 1 and 1.5 bar turn both taps off.
3. Disconnect the filling pipe from the taps (a small amount of water may be present) and remove it. Keep the pipe in a safe place for future use.
4. If blanking caps are available fit them to the taps.

**See**  
 Go to the "How to videos" section of the "Information & advice" page at [www.baxi.co.uk](http://www.baxi.co.uk) for further details.

5. When the correct pressure is restored the boiler will reset automatically.

## 6.3 Venting the installation

Fig.10 Venting the radiators

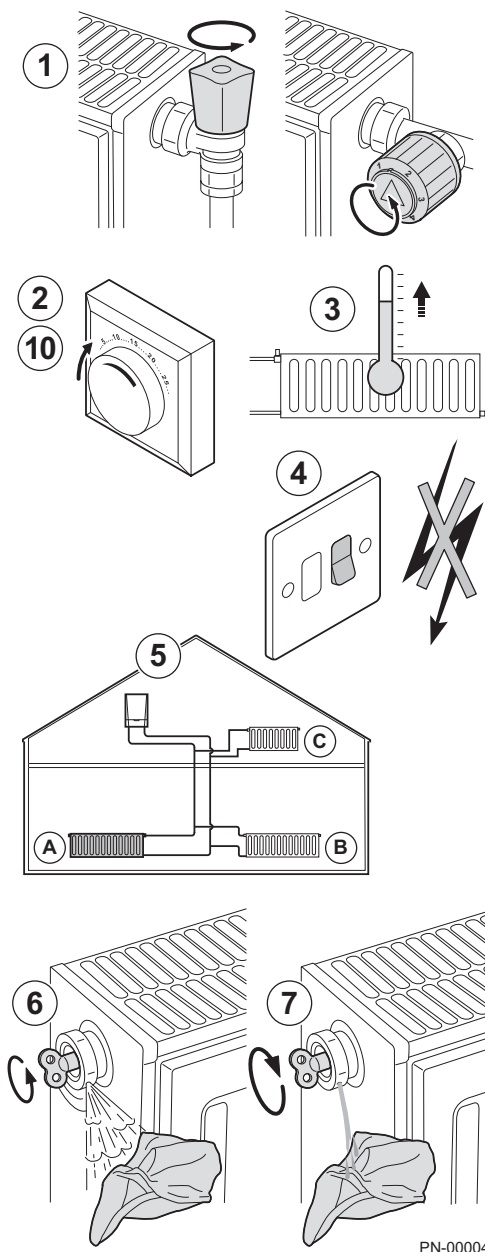

If any air is present in the appliance or system it must be removed in order to prevent nuisance noises that may occur during heating or when drawing off hot water. Proceed as follows:

1. Open the valves of all the radiators connected to the system.
2. Set the room thermostat to the highest possible temperature and any timers to 'ON'.
3. Wait until the radiators are warm.
4. Switch off the boiler.
5. Vent the radiators. Work from the lowest radiator in the property.
6. Open the bleed vent with the key, keeping a cloth pressed against the vent.
7. Wait until water comes out of the bleed vent and then close.



### Warning

The CH water in the radiators will still be hot.

8. Switch the boiler on.
9. After venting, check that the water pressure in the system is still adequate.



### Important

If the water pressure is lower than 0.7 bar, the water must be topped up. If necessary repressurise the system (recommended pressure between 1 and 1.5 bar when cold).

10. Reset the room thermostat to the desired temperature.

Fig.11 Enabling de-aeration function

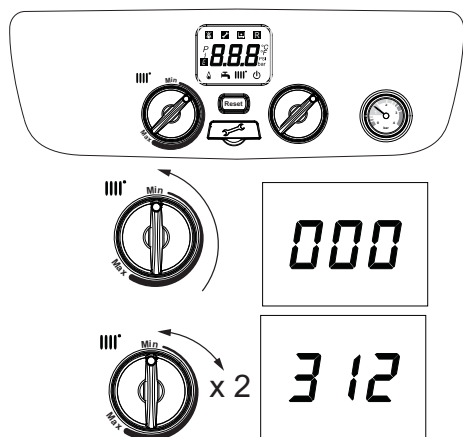

The purpose of the function is to remove as much air as possible from the heating system.

1. Turn off the power to the boiler and rotate the CH control knob fully anticlockwise.
2. Turn on the power to the boiler. The display shows "000" .
3. Turn the CH control knob (III)  $\frac{1}{4}$  turn clockwise twice in quick succession (within 2 seconds).
4. Display shows "312" while de-aeration is taking place (approximately 7 minutes).
5. When de-aeration has completed, the display will show the primary flow temperature and the CH (III) symbols.

PN-0000392

**Caution**  
 If the system is drained (even partly, when replacing a radiator for example) the de-aeration function must be repeated. Also the inhibitor concentration must be checked and replenished if necessary.

### 6.4 Draining the installation

Fig.12 Draining the installation

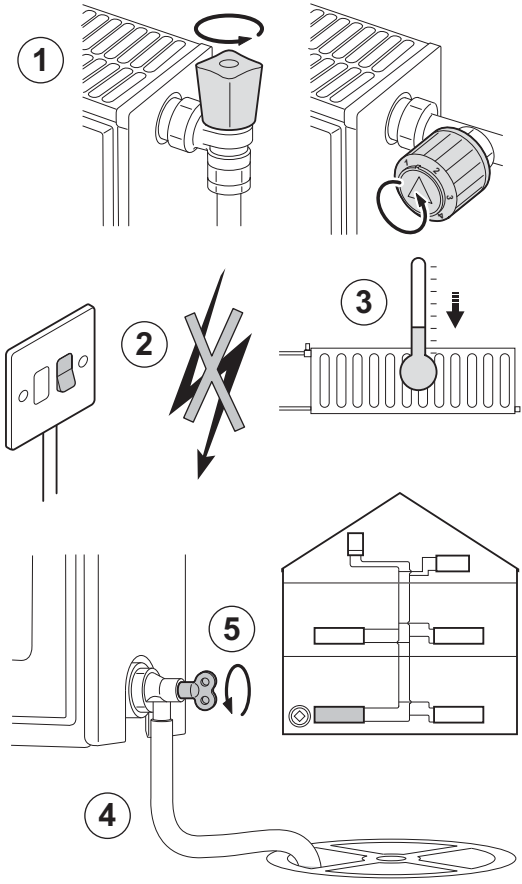

It may be necessary to drain the central heating system if radiators need to be replaced, if there is a major water leak or if there is a risk of freezing. Proceed as follows:

1. Open the valves of all the radiators connected to the system.
2. Switch off the boiler's electrical connection.
3. Wait approximately ten minutes, until the radiators feel cold.
4. Connect a drain hose to the lowest draining point. Place the end of the hose in a drain or at a place where drained pipe water will not cause any damage.
5. Open the central heating system fill/drain valve. Drain the installation.

**Warning**  
 The water may still be hot.

6. Close the drain valve when no more water comes from the draining point.

**Important**  
 After draining the system, the concentration of corrosion inhibitor and antifreeze agent may be extremely diluted - check with your installer.

AD-3000730-01

## 7 Troubleshooting

### 7.1 Error codes

Fig.13 Control panel error display

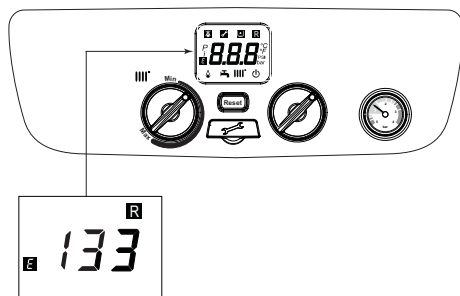



PN-0000393

#### 7.1.1 List of error codes

Tab.8 Table of error codes

Error code	Description of fault
<b>E</b> 09	Gas valve connection cable
<b>E</b> 15	Gas valve fault
<b>E</b> 20	Central heating NTC fault
<b>E</b> 28	Flue NTC fault
<b>E</b> 40	Central heating return NTC fault
<b>E</b> 83	Communication error
<b>E</b> 109	Pre-circulation fault
<b>E</b> 110	Safety thermostat operated
<b>E</b> 118	Primary system water pressure too low
<b>E</b> 125	Circulation fault (primary)
<b>E</b> 128	Flame failure
<b>E</b> 130	Flue NTC operated
<b>E</b> 133	Interruption of gas supply or flame failure
<b>E</b> 135	Interruption of gas supply (internal error)
<b>E</b> 154	Flow / return sensor temperature test
<b>E</b> 160	Fan or fan wiring fault
<b>E</b> 270	Circulation fault (Dry fire)
<b>E</b> 384	False flame

The display shows two types of signals:  and **R**. In both cases the display shows **E** symbol and the numeric value of the error (see the table of error codes above).

The spanner  symbol appears it cannot be reset by the user. Please contact your Installer, Annual Service Provider or Baxi Customer Support. You can contact Baxi Customer Support on 0344 871 1545.

**R** fault errors can be reset by pressing the **Reset** button.

For **E** 103, 104, 107 & "Bat" please contact your installer, annual service provider or Baxi Customer Support

**Important**  
 If a different error code from those described in the "Table of error codes" appears on the display contact Baxi Customer Support.

## 7.2 Fault finding

Tab.9 Problems and solutions

Problem	Possible causes	Solution
The radiators are cold.	The temperature set point for the heating is too low.	Increase the value with the CH temperature knob or if a room thermostat is connected, increase the temperature on the room thermostat.
	The heating mode is deactivated.	Activate the heating mode.
	The radiator valves are not open.	Open the valves of all radiators connected to the system.
	The boiler is not working.	Check that the boiler is being supplied with power. Check fuses and switches. Check whether the gas isolation cock is properly open. If the property has a prepayment meter ensure it has sufficient credit.
	The water pressure is too low (< 0.5 bar).	Re-pressurise the system.
The boiler is not working.	The temperature set point for the heating is too low.	Increase the value with the CH temperature knob or if a room thermostat is connected, increase the temperature on the room thermostat.
	No demand for heating.	Ensure that timers & thermostats are calling for heat.
	No power supply.	Check that the boiler is being supplied with power. Check the fuses and switches.
	The water pressure is too low (< 0.5 bar).	Re-pressurise the system.
	The boiler is indicating an error.	Press the Reset button. Correct the error, if possible.
	The gas pressure is too low.	Check whether the gas isolation cock is fully open. Open the gas isolation cock.
	Condensate drain blocked.	Check drain, especially any external runs in freezing temperatures.

If the boiler is not working also check section "Operation checking procedure and basic fault identification" or contact your Installer.

## 8 Decommissioning

### 8.1 Decommissioning procedure

---

**Caution**

Only qualified persons are authorised to work on the appliance and system to decommission.

If your boiler needs to be decommissioned either temporarily or permanently the following should be performed:

1. Switch off the boiler's electrical connection.
2. Close the gas isolation tap.
3. Drain the central heating system.

Seek the advice of your installer.

## 9 Disposal

### 9.1 Disposal and recycling

---



**Caution**

Removal and disposal of the boiler must be carried out by a qualified person in accordance with local and national regulations.



## 10 Environmental

### 10.1 Energy saving

---

Tips on saving energy:

- Do not cover radiators. Do not hang curtains in front of radiators.
- Install reflective panels behind the radiators to prevent heat loss.
- Insulate the pipes in rooms that are not heated (cellars and lofts).
- Install loft insulation & double glazing.
- Use draught excluders where necessary.
- Upgrade any older boiler external controls.
- Turn down room thermostats by 1°.
- Turn off radiators in rooms not in use.
- Do not run hot (or cold) water pointlessly.
- Fit a water-saving shower head to save up to 40 % energy.
- Take showers rather than baths. A bath consumes twice as much water and energy.

### 10.2 Room thermostats and settings

---

Various models of room thermostat are available. The thermostat type and setting affect the total energy consumption.

A few tips:

- A modulating thermostat in combination with thermostatic radiator valves saves energy and offers considerable comfort. This combination gives you flexibility with the temperatures. Do not fit thermostatic radiator valves in the room in which the room thermostat is installed.
- Completely closing and opening thermostatic valve radiators causes undesirable temperature fluctuations. Open and close thermostatic valves in small steps.
- Lower the thermostat to around 20°C. This reduces heating costs and energy consumption.
- Lower the room thermostat temperature temporarily if opening windows to air the rooms.
- If you are using an ON/OFF type thermostat, reduce the water temperature value in summer (e.g. 60°C in summer and 80°C in winter).
- When setting an hourly programmable thermostat, consider days when you are absent or on holiday. Electricity production and energy savings reach their optimum level with a programmed and activated timer programme.

## 11 Warranty

### 11.1 General

---

To make sure your boiler warranty is activated and maintained, it is essential that the:

1. Benchmark checklist is completed by your installer
2. Warranty is registered within 30 days
3. Boiler has an annual service



**Important**

Please note that failure to adhere to terms and conditions will invalidate your warranty.

### 11.2 Standard warranty terms and conditions

---

**Warranty registration, service & repair**

For full terms and conditions, visit [www.baxi.co.uk/terms](http://www.baxi.co.uk/terms).

**Benchmark checklist**

The Benchmark Checklist will be completed by your installer and records that the boiler has been installed and commissioned correctly. It can be found at the back of the installation and service manual and should be kept in a safe place for the life of the boiler. We will check that the Benchmark Checklist has been completed on an in-warranty visit.

**Ways to register your warranty**

If your boiler is eligible for an extended warranty, your installer may register the product on your behalf and provide you with the relevant documentation. Please check with your installer.

Should this not be the case, you can register your warranty online at [www.baxi.co.uk/registration](http://www.baxi.co.uk/registration)

**Annual service**

A service must be completed every 12 months from the date of installation to maintain your warranty.

This service must be completed by one of the following:

- A Gas Safe registered installer/engineer
- Baxi Customer Support; call us 0344 871 1545

Please make sure that your engineer has logged the service information at the back of the installation and service manual. You will be asked for your service history on any in-warranty repair visit.

**If you experience a problem with your boiler**

For any in or out of warranty repair, Baxi Customer Support is on hand to help you. Call our award-winning team to arrange for one of our nationwide team of Gas Safe registered engineers to visit.

If your product is in warranty, everything is free of charge, subject to our warranty terms and conditions. If it is out of warranty, we can still help and offer a range of options you can choose from to suit your needs.

**Contact Baxi Customer Support 0344 871 1545**

**Opening hours**

Monday - Friday, 8.00am - 6.00pm

Weekends and Bank Holidays, 8.30am - 2.00pm

Please note calls may be recorded for training and monitoring purposes.

When contacting Baxi Customer Support, please have the following information to hand:

- Boiler serial number.

- Proof of purchase if you do not have the boiler serial number

Please note that for in-warranty repairs, our engineers will ask to see your service history record, completed Benchmark Checklist and details of your installer. These can all be found in the Installation and Service manual.

## 12 Appendix

### 12.1 Product fiche - Boiler space heaters

---

Tab.10 Product fiche for boiler space heaters

<b>Baxi System</b>		<b>818</b>	<b>824</b>
Seasonal space heating energy efficiency class		<b>A</b>	<b>A</b>
Rated heat output ( <i>Prated or Psup</i> )	kW	18	24
Seasonal space heating energy efficiency	%	93	93
Annual energy consumption	GJ	56	74
Sound power level $L_{WA}$ indoors	dB	48	51

**See**

For specific precautions about assembling, installing and maintaining: Safety, page 5

## 12.2 Package fiche - boilers

Fig.14 Package fiche for boilers indicating the space heating energy efficiency of the package

<b>Seasonal space heating energy efficiency of boiler</b>		① [ ] %																														
<b>Temperature control</b> from fiche of temperature control	Class I = 1%, Class II = 2%, Class III = 1.5%, Class IV = 2%, Class V = 3%, Class VI = 4%, Class VII = 3.5%, Class VIII = 5%	② + [ ] %																														
<b>Supplementary boiler</b> from fiche of boiler	Seasonal space heating energy efficiency (in %)  ( [ ] - 'I' ) x 0.1 = ± [ ] %	③ [ ] %																														
<b>Solar contribution</b> from fiche of solar device	<div style="display: flex; justify-content: space-between;"> <div style="border: 1px solid black; padding: 2px;">Collector size (in m<sup>2</sup>)</div> <div style="border: 1px solid black; padding: 2px;">Tank volume (in m<sup>3</sup>)</div> <div style="border: 1px solid black; padding: 2px;">Collector efficiency (in %)</div> <div style="border: 1px solid black; padding: 2px;">Tank rating <sup>(1)</sup> A* = 0.95, A = 0.91, B = 0.86, C = 0.83, D - G = 0.81</div> </div> ( 'III' x [ ] + 'IV' x [ ] ) x 0.9 x ( [ ] /100 ) x [ ] = + [ ] %	④ [ ] %																														
<b>Supplementary heat pump</b> from fiche of heat pump	Seasonal space heating energy efficiency (in %)  ( [ ] - 'I' ) x 'II' = + [ ] %	⑤ [ ] %																														
<b>Solar contribution AND Supplementary heat pump</b> select smaller value	0.5 x [ ] OR 0.5 x [ ] = - [ ] %	⑥ [ ] %																														
<b>Seasonal space heating energy efficiency of package</b>		⑦ [ ] %																														
<b>Seasonal space heating energy efficiency class of package</b>																																
<table border="1" style="width: 100%; border-collapse: collapse;"> <tr> <td style="text-align: center;">☐</td> <td style="text-align: center;">☐</td> <td style="text-align: center;">☐</td> <td style="text-align: center;">☐</td> <td style="text-align: center;">☐</td> <td style="text-align: center;">☐</td> <td style="text-align: center;">☐</td> <td style="text-align: center;">☐</td> <td style="text-align: center;">☐</td> <td style="text-align: center;">☐</td> </tr> <tr> <td style="text-align: center;"><b>G</b></td> <td style="text-align: center;"><b>F</b></td> <td style="text-align: center;"><b>E</b></td> <td style="text-align: center;"><b>D</b></td> <td style="text-align: center;"><b>C</b></td> <td style="text-align: center;"><b>B</b></td> <td style="text-align: center;"><b>A</b></td> <td style="text-align: center;"><b>A<sup>+</sup></b></td> <td style="text-align: center;"><b>A<sup>++</sup></b></td> <td style="text-align: center;"><b>A<sup>+++</sup></b></td> </tr> <tr> <td style="text-align: center;">&lt;30%</td> <td style="text-align: center;">≥30%</td> <td style="text-align: center;">≥34%</td> <td style="text-align: center;">≥36%</td> <td style="text-align: center;">≥75%</td> <td style="text-align: center;">≥82%</td> <td style="text-align: center;">≥90%</td> <td style="text-align: center;">≥98%</td> <td style="text-align: center;">≥125%</td> <td style="text-align: center;">≥150%</td> </tr> </table>			☐	☐	☐	☐	☐	☐	☐	☐	☐	☐	<b>G</b>	<b>F</b>	<b>E</b>	<b>D</b>	<b>C</b>	<b>B</b>	<b>A</b>	<b>A<sup>+</sup></b>	<b>A<sup>++</sup></b>	<b>A<sup>+++</sup></b>	<30%	≥30%	≥34%	≥36%	≥75%	≥82%	≥90%	≥98%	≥125%	≥150%
☐	☐	☐	☐	☐	☐	☐	☐	☐	☐																							
<b>G</b>	<b>F</b>	<b>E</b>	<b>D</b>	<b>C</b>	<b>B</b>	<b>A</b>	<b>A<sup>+</sup></b>	<b>A<sup>++</sup></b>	<b>A<sup>+++</sup></b>																							
<30%	≥30%	≥34%	≥36%	≥75%	≥82%	≥90%	≥98%	≥125%	≥150%																							
<b>Boiler and supplementary heat pump installed with low temperature heat emitters at 35°C ?</b>																																
from fiche of heat pump	[ ] + (50 x 'II') = [ ] %	⑦ [ ] %																														

The energy efficiency of the package of products provided for in this fiche may not correspond to its actual energy efficiency once installed in a building, as this efficiency is influenced by further factors such as heat loss in the distribution system and the dimensioning of the products in relation to building size and characteristics.

- I The value of the seasonal space heating energy efficiency of the preferential space heater, expressed in %.
- II The factor for weighting the heat output of preferential and supplementary heaters of a package as set out in the following table.
- III The value of the mathematical expression:  $294/(11 \cdot \text{Prated})$ , whereby 'Prated' is related to the preferential space heater.
- IV The value of the mathematical expression  $115/(11 \cdot \text{Prated})$ , whereby 'Prated' is related to the preferential space heater.

Tab.11 Weighting of boilers

$P_{sup} / (P_{rated} + P_{sup})^{(1)(2)}$	II, package without hot water storage tank	II, package with hot water storage tank
0	0	0
0.1	0.3	0.37
0.2	0.55	0.70
0.3	0.75	0.85
0.4	0.85	0.94
0.5	0.95	0.98
0.6	0.98	1.00
$\geq 0.7$	1.00	1.00

(1) The intermediate values are calculated by linear interpolation between the two adjacent values.  
(2) Prated is related to the preferential space heater or combination heater.

Tab.12 Package efficiency

Baxi System		818	824
Temperature control X	%		
Temperature control Y	%		

© Copyright

All technical and technological information contained in these technical instructions, as well as any drawings and technical descriptions supplied, remain our property and shall not be multiplied without our prior consent in writing. Subject to alterations.

## Baxi Customer Support



**0344 871 1545**

### Opening hours

Monday - Friday, 8.00am-6.00pm

Weekends and Bank Holidays, 8.30am-2.00pm

Please note calls may be recorded for training and monitoring purposes



**baxi.co.uk**

Register now to activate your warranty:

**[www.baxi.co.uk/registration](http://www.baxi.co.uk/registration)**

For the warranty to be maintained, please make sure...

- 1 Benchmark checklist is completed
- 2 Warranty is registered within 30 days
- 3 The boiler has an annual service

For full terms and conditions, visit [www.baxi.co.uk/terms](http://www.baxi.co.uk/terms). Failure to adhere to terms and conditions will void your manufacturer's warranty.



Baxi  
Brooks House,  
Coventry Road,  
Warwick, CV34 4LL

**CE**  
0085



Please ensure the boiler is installed in accordance with these installation instructions and that you adhere to the Building Regulations.



e&oe

All descriptions and illustrations provided in this document have been carefully prepared but we reserve the right to make changes and improvements in our products which may affect the accuracy of the information contained in this leaflet. All goods are sold subject to our standard Conditions of Sale which are available on request.

7729934-01

**BAXI**