

## **User Guide**

Gas Fired Wall Mounted Condensing Boiler

**Heat**  
816 - 825 - 830

Please keep these instructions in a safe place.  
If you move house please hand them over to the next occupier.

## Model Range

---

**Baxi 816 Heat**

G.C.N° 41-470-77

**Baxi 825 Heat**

G.C.N° 41-470-78

**Baxi 830 Heat**

G.C.N° 41-470-79

### Dear Customer,

Thank you for purchasing this appliance.

Please read this manual carefully before using the product and keep it in a safe place for future reference.

In order to ensure continued safe and efficient operation we recommend that the product is regularly maintained. Our Service and After Sales organization can assist with this.

We hope you will receive many years of satisfactory service.

© **Baxi Heating UK Ltd 2023** All rights reserved. No part of this publication may be reproduced or transmitted in any form or by any means, or stored in any retrieval system of any nature (including in any database), in each case whether electronic, mechanical, recording or otherwise, without the prior written permission of the copyright owner, except for permitted fair dealing under Copyrights, Designs and Patents Act 1988.

Applications for the copyright owner's permission to reproduce or make other use of any part of this publication should be made, giving details of the proposed use, to the following address:

The Company Secretary, Baxi Heating UK Limited,  
Brooks House, Coventry Road, Warwick. CV34 4LL

Full acknowledgement of author and source must be given.

**WARNING:** Any person who does any unauthorised act in relation to a copyright work may be liable to criminal prosecution and civil claims for damages.



ISO 9001  
FM 00866



### The Benchmark Scheme

Baxi Heating UK Ltd is a licensed member of the Benchmark Scheme which aims to improve the standards of installation and commissioning of domestic heating and hot water systems in the UK and to encourage regular servicing to optimise safety, efficiency and performance.

Benchmark is managed and promoted by Heating and Hotwater Industry Council. For more information visit [www.centralheating.co.uk](http://www.centralheating.co.uk)

# Contents

---

<b>1</b>	<b>Introduction</b> .....	<b>6</b>
1.1	General .....	6
1.2	Additional Documentation .....	6
1.3	Symbols Used .....	6
1.4	Abbreviations / Glossary .....	7
1.5	Extent of Liabilities .....	7
1.5.1	Manufacturer's Liability .....	7
1.5.2	Installer's Responsibility .....	8
1.5.3	User's Responsibility .....	8
<b>2</b>	<b>Safety</b> .....	<b>9</b>
2.1	General Safety Instructions .....	9
2.2	Recommendations .....	10
2.2.1	Benchmark Commissioning Checklist .....	10
<b>3</b>	<b>Technical Specifications</b> .....	<b>11</b>
3.1	Technical Data .....	11
3.1.1	Clearances .....	12
<b>4</b>	<b>Description of the Product</b> .....	<b>13</b>
4.1	General Description .....	13
4.2	Operating Principle .....	13
4.2.1	In Operation .....	13
4.3	Control Panel Description .....	14
4.3.1	User Interaction Controller .....	14
4.3.2	Indicator Lights .....	14
4.4	Standard Delivery .....	15
4.5	Accessories & Options .....	15
4.5.1	Optional Extras .....	15
<b>5</b>	<b>Operation</b> .....	<b>16</b>
5.1	Operation Checking Procedure & Basic Fault Identification .....	16
5.2	Shutdown .....	18
5.3	Frost Protection .....	18
<b>6</b>	<b>Settings</b> .....	<b>18</b>
6.1	Setting the Boiler Flow Temperature .....	18
<b>7</b>	<b>Maintenance</b> .....	<b>19</b>
7.1	General .....	19
7.2	Maintenance Instructions .....	19
7.3	Filling the System .....	20
7.4	Venting the System .....	21
7.5	Draining the System .....	22

<b>8</b>	<b>Troubleshooting</b> .....	<b>23</b>
8.1	Fault Warning & Lock-out Codes .....	23
8.2	Fault Finding .....	24
<b>9</b>	<b>Decommissioning</b> .....	<b>25</b>
9.1	Decommissioning Procedure .....	25
<b>10</b>	<b>Disposal</b> .....	<b>25</b>
10.1	Disposal / Recycling .....	25
<b>11</b>	<b>Environmental</b> .....	<b>26</b>
11.1	Energy Saving .....	26
11.2	Room Thermostats and Settings .....	26
<b>12</b>	<b>Warranty</b> .....	<b>27</b>
12.1	General .....	27
12.2	Terms of Warranty .....	27
	12.2.1 Standard Warranty Terms and Conditions .....	27
<b>13</b>	<b>Appendix</b> .....	<b>29</b>
13.1	ErP Information .....	29
	13.1.1 Product Fiche - Boiler Space Heaters .....	29
	13.1.2 Package Fiche - Boilers .....	30

This page is intentionally blank

# 1 Introduction

---

## 1.1 General

---



**WARNING**

Installation, repair and maintenance must only be carried out only by a competent person. This document is intended for use by competent persons,

All Gas Safe registered engineers carry an ID card with their licence number and a photograph. You can check your engineer is registered by telephoning 0800 408 5500 or online at [www.gassaferegister.co.uk](http://www.gassaferegister.co.uk)

This manual is intended for the user of the Baxi 800 Heat boiler. If the appliance is sold or transferred, or if the owner moves leaving the appliance behind you should ensure that the manual is kept with the appliance for consultation by the new owner and their installer.

The appliance is designed as a boiler for use in residential domestic environments on a governed meter supply only. The selection of this boiler is entirely at the owner's risk. If the appliance is used for purposes other than or in excess of these specifications, the manufacturer will not accept any liability for resulting loss, damage or injury.

**The manufacturer will not accept any liability whatsoever for loss, damage or injury arising as a result of failure to observe the instructions for use, maintenance and installation of the appliance.**

## 1.2 Additional Documentation

---

Various timers, external controls, etc. are available as optional extras. Full details are contained in the relevant sales literature.

## 1.3 Symbols Used

---

In these instructions, various danger levels are employed to draw the user's attention to particular information. In so doing, we wish to safeguard the user's safety, prevent hazards and guarantee correct operation of the appliance.



**DANGER**

Risk of a dangerous situation causing serious physical injury.



**WARNING**

Risk of a dangerous situation causing slight physical injury.



**CAUTION**

Risk of material damage.



Signals important information.



Signals a referral to other instructions or other pages in the instructions.

## 1.4 Abbreviations / Glossary

---

- ▶ **DHW:** Domestic Hot Water
- ▶ **CH:** Central Heating
- ▶ **GB:** Great Britain
- ▶ **IE:** Ireland
- ▶ **BS:** British Standard
- ▶ **HHIC:** Heating and Hotwater Industry Council

## 1.5 Extent of Liabilities

---

### 1.5.1. Manufacturer's Liability

---

Our products are manufactured in compliance with the requirements of all applicable Directives and Regulations. They are therefore delivered with **CE** marking and all relevant documentation. In the interest of customers, we are continuously endeavouring to make improvements in product quality. All the specifications stated in this document are therefore subject to change without notice.

The manufacturer will not accept any liability for loss, damage or injury arising as a result of:-

- ▶ Failure to abide by the instructions on using the appliance.
- ▶ Failure to regularly maintain the appliance, or faulty or inadequate maintenance of the appliance.
- ▶ Failure to abide by the instructions on installing the appliance.

**This company declares that no substances harmful to health are contained in the appliance or used during appliance manufacture.**

The appliance is suitable only for installation in GB and IE and should be installed in accordance with the rules in force, and only used in a suitably ventilated location.

**In GB**, the installation must be carried out by a Gas Safe Registered Installer. It must be carried out in accordance with the current and relevant requirements of legislation and guidance.

Where no specific instructions are given, reference should be made to the relevant British Standard Code of Practice.

**In IE**, the installation must be carried out by a competent person and installed in accordance with the current edition of I.S. 813 'Domestic Gas Installations', the current Building Regulations and reference should be made to the current ETCl rules for electrical installation.

Incorrect installation could invalidate the warranty and may lead to prosecution.

### 1.5.2 Installer's Responsibility

---

The installer is responsible for the installation and initial start up of the appliance. The installer must adhere to the following instructions:

- ▶ Read and follow the instructions given in the manuals provided with the appliance.
- ▶ Carry out installation in compliance with the prevailing legislation and standards.
- ▶ Ensure the system is flushed and inhibitor added.
- ▶ Install the flue/chimney system correctly ensuring it is operational and complies with prevailing legislation and standards, regardless of location of the boiler's installation.
- ▶ Only the installer should perform the initial start up and carry out any checks necessary.
- ▶ Explain the installation to the user.
- ▶ Complete the Benchmark Commissioning Checklist in the Installation Manual - this is a condition of the warranty !
- ▶ Warn the user of the obligation to check the appliance and maintain it in good working order.
- ▶ Give all the instruction manuals to the user.

### 1.5.3. User's Responsibility

---

To guarantee optimum operation of the installation, you must observe the following instructions:

- ▶ Read and observe the instructions given in the manuals supplied with the appliance.
- ▶ Seek the assistance of a qualified installer for the installation and initial commissioning.
- ▶ Ask the installer to explain the installation.
- ▶ Have the required annual inspection and maintenance carried out by a qualified installer and ensure the Benchmark Service Record in the Installation Manual is completed - this is a condition of the warranty !
- ▶ Keep the manuals in good condition and near to the appliance.

This appliance must not be used by people with a lack of experience or knowledge, unless they are supervised by someone familiar with the appliance or if they have been instructed on how to operate the appliance correctly. Do not allow children to operate or play with the appliance.



## 2 Safety

### 2.1 General Safety Instructions

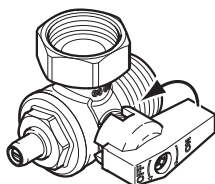

#### DANGER

If you smell gas:

1. Turn off the gas supply at the meter
2. Open windows and doors in the hazardous area
3. Do not operate light switches
4. Do not operate any electrical equipment
5. Do not use a telephone in the hazardous area
6. Extinguish any naked flame and do not smoke
7. Warn any other occupants and vacate the premises
8. Telephone the National Gas Emergency Service on:- 0800 111 999



The boiler can be isolated at the gas valve under the appliance by turning the tap through 90° (1/4 turn).

For advice please contact your Installer, Annual Service Provider or **Baxi Customer Support** - The Service Division of Baxi. You can contact **Baxi Customer Support** on telephone number **0344 871 1545**.

When contacting **Baxi Customer Support** it will be useful to have the '**Benchmark Checklist**' at the back of the Installation & Service Manual to hand as it includes details relevant to the boiler and installation.



#### WARNING

Do not touch flue/chimney pipes. Depending on the settings of the appliance, the temperature of flue/chimney pipes may exceed 60 °C.

Do not touch radiators for long periods. Depending on the settings of the appliance, the temperature of radiators may reach 85 °C.

Take precautions with domestic hot water. Depending on the settings of the appliance & cylinder thermostat, domestic hot water temperature may exceed 65 °C.



#### CAUTION

Do not neglect to service the appliance. Contact a qualified professional or take out a maintenance contract for the annual servicing of the appliance.



#### WARNING

This boiler can be used by children aged 8 years and above and by persons with reduced physical, sensory or mental capabilities or lack of experience and knowledge when they have been given supervision or instruction concerning the safe use of the device and understand the resulting risks. Children must not be allowed to play with the appliance. Cleaning and user maintenance must not be carried out by children without supervision.

## 2.2 Recommendations

---



### CAUTION

Only qualified professionals are authorised to work on the appliance and the installation.



For sealed systems regularly check the water pressure in the system (recommended pressure is 1.5 bar). Your installer will advise on the method of repressurising if required.

Keep the appliance accessible at all times.

Do not remove or cover the serial number label affixed to the slide-out flap at the boiler lower left. It must remain legible throughout the lifetime of the appliance.

### 2.2.1 Benchmark Commissioning Checklist

---

1. Please ensure that the installer has fully completed the Benchmark Checklist on the inside back pages of the installation instructions supplied with the product and that you have signed it to say that you have received a full and clear explanation of its operation. The installer is legally required to complete a commissioning checklist as a means of complying with the appropriate Building Regulations (England and Wales).

2. All installations must be notified, by the installer, to Local Area Building Control either directly or through a Competent Persons Scheme. A Building Regulations Compliance Certificate will then be issued to the customer who should, on receipt, write the Notification Number on the Benchmark Checklist.

3. This product should be serviced annually to optimise its safety, efficiency and performance. The service engineer should complete the relevant section of the Benchmark Service Record in the Installation & Service manual after each service.

4. The completed Benchmark Checklist & proof of annual servicing (where applicable) will be required in the event of any warranty work.



See Section 12 for warranty information.

### 3 Technical Specifications

#### 3.1 Technical Data

**NOTE:** All data in this section are nominal values and subject to normal production tolerances.

**Flow Temperature** (adjustable)  
30° C to 80° C (± 5° C)

**Outercase Dimensions**

Overall Height Inc Flue Elbow	-	790mm
Casing Height	-	625mm
Casing Width	-	370mm
Casing Depth	-	280mm

**Clearances**

Both Sides	5mm Min
Above Casing (Top Flue)	190mm Min
Above Casing (Rear Flue)	35mm Min
Below Casing (in Cupboard)	35mm Min
Below Casing	120mm Min
Front (For Servicing)	500mm Min
Front (In Operation)	5mm Min

**Ventilation of Compartment**

Where the boiler is installed in a cupboard or compartment, no air vents are required for cooling purposes providing that the minimum dimensions above are maintained.

**Electrical Supply**

230V~ 50Hz  
(Appliance must be connected to an earthed supply)

**Power Consumption**

816 model	20W
825 model	33W
830 model	44W

**External Fuse Rating**

3A

### 3.1.1. Clearances

1. A flat vertical area is required for the installation of the boiler.
2. These dimensions include the necessary clearances around the boiler for case removal, spanner access and air movement (Figs. 1 & 2). Additional clearances may be required for the passage of pipes around local obstructions such as joists running parallel to the front face of the boiler.

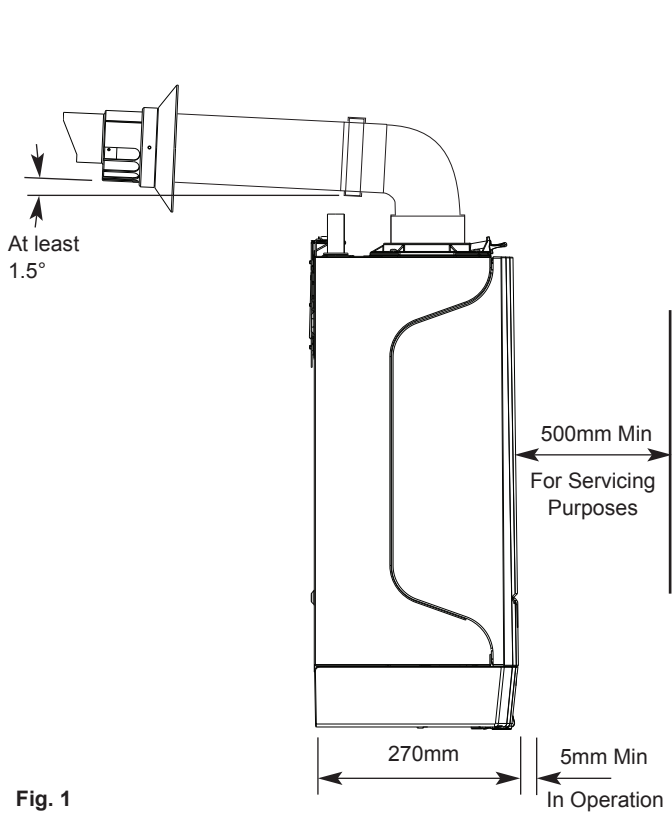

Fig. 1

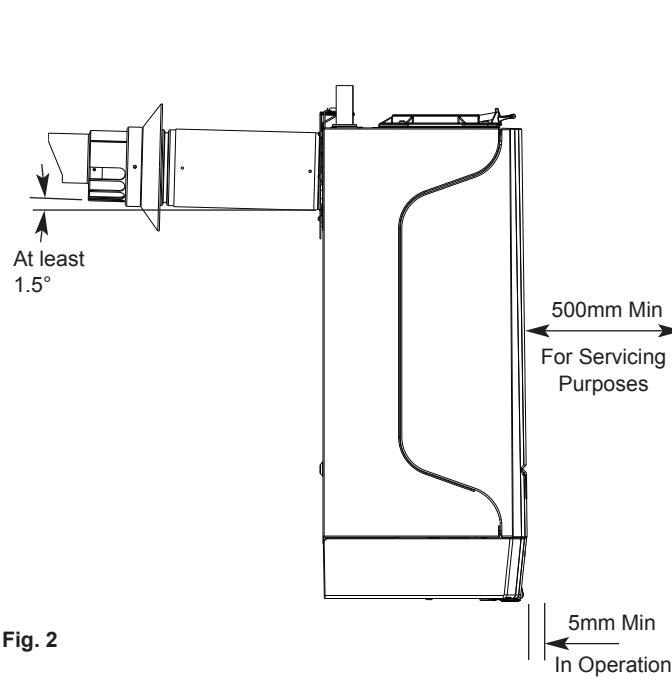
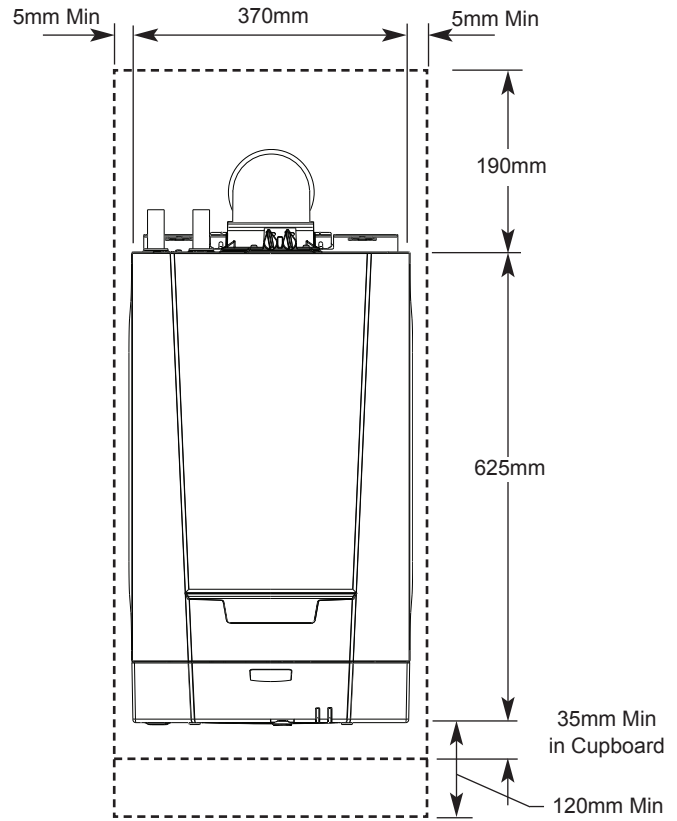
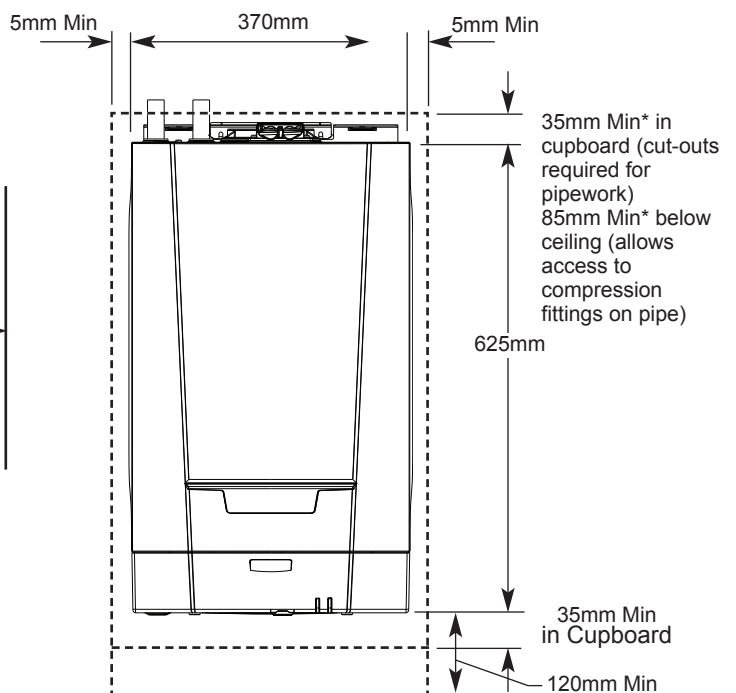

Fig. 2



## 4 Description of the Product

---

### 4.1 General Description

---

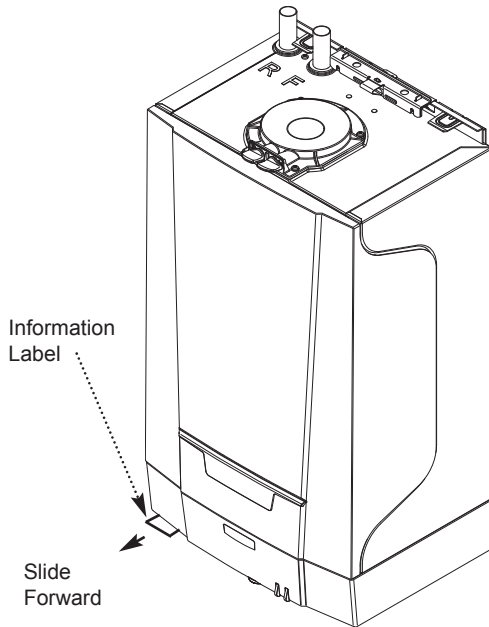

Fig. 3

1. The Baxi 800 Heat is a wall mounted condensing boiler which is room sealed and fan assisted, and will serve central heating and stored domestic hot water

2. The boiler will be one of the following outputs:-

816 model - 16 kW

825 model - 25 kW

830 model - 30 kW

3. The boiler is factory set for use only on Natural Gas (G20).

4. The boiler model, serial number and Gas Council number are shown on the information label under the boiler (Fig. 3). This is for user reference.

### 4.2 Operating Principle

---

#### 4.2.1 In Operation

---

1. Whilst the boiler is in operation cooled flue gases are discharged through the flue gas discharge pipe. This may appear as a cloud of steam which is normal.

2. Condensed water is discharged from the boiler heat exchanger into a pipe (the condensate drain). This pipe must never be altered or re-routed except by a qualified professional.

### 4.3 Control Panel Description

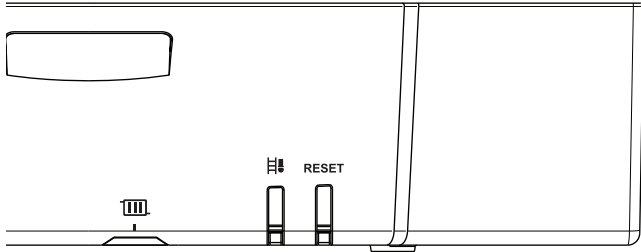

Fig. 4

#### 4.3.1 User Interaction Controller (Fig. 4)

Key to symbols:-





Heating Water Temperature



Sweep Key and Status Signals

**RESET** Reset button and On/Off Signal

1. The User Interaction Controller has 2 illuminating push buttons which provide information about the operating condition of the boiler.
2. The **RESET** button illuminates green when the boiler receives a demand for CH or DHW.
3. The  button can flash orange, green or red and at different frequencies.
4. The User Interaction Controller also has one rotary knob. The  rotary knob is used to set the maximum flow temperature of the heating water.
5. The temperature selected by the rotary knob must be set to a higher temperature than the cylinder thermostat to achieve the required hot water demand.

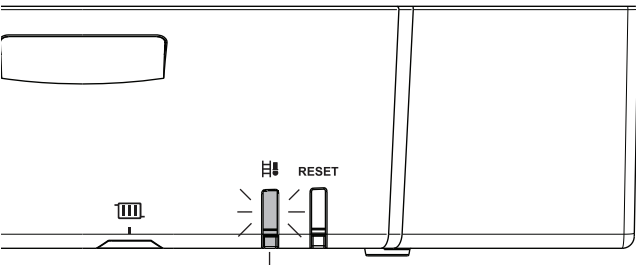



Fig. 5

Normal Operation - The  green light remains on for around seven seconds and then extinguishes briefly, repeating the sequence whilst the boiler is operating.

The  symbol indicates the Status Light ON.

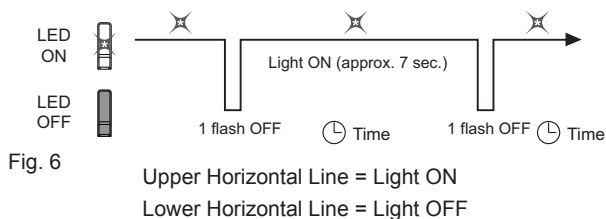







Fig. 6

#### 4.3.2 Indicator Lights (Fig. 5)

The colour of the status light  on the boiler control panel and the number of times that it flashes indicates whether the boiler is working normally, has a problem or requires servicing.

 See Section 8.1. for details of the fault conditions.

**Boiler Operating** The  light will flash orange at EVERY heating demand. The number of flashes will correspond with the heat output of the boiler. This is normal and does not indicate a fault condition. During normal running  illuminates green and blinks off momentarily every seven seconds approximately to show the boiler is running normally and supplying heat (Fig. 6).

**Error** When flashing green  light indicates that the boiler has detected a problem, and is attempting to resolve it. If it does not succeed the boiler will go into fault mode and display a red light.

**Defect** When flashing red  light indicates that the boiler has a fault. Press the RESET button for a minimum of 5 seconds to try and clear the fault condition.

A lock-out condition can be re-set up to 5 times within one hour using the reset button. Any fault that occurs repeatedly should be fully investigated and appropriate remedial actions taken by your installer or **Baxi Customer Support**.

If there is a continuous red light, contact your installer or **Baxi Customer Support**

The lights will be OFF when there is no demand for heat.

## 4.4 Standard Delivery

---

1. The literature pack contains:

- ▶ Literature pack
  - Installation & Servicing Manual (including 'benchmark')
  - User Guide Instructions
  - Flue Accessories & Fitting Guide
  - Warranty Documentation
  - Wall Template
  - Product Leaflet
  - Package Leaflet

## 4.5 Accessories & Options

---

### 4.5.1 Optional Extras

---

1. Various items are available as optional extras.

Flue Accessories (elbows, extensions, clamps etc.)  
(refer to the Flue Accessories & Fitting Guide supplied in the literature pack.)

Remote relief valve kit

1M Condensate Drain Pipe 'Trace Heating' Element

2M Condensate Drain Pipe 'Trace Heating' Element

3M Condensate Drain Pipe 'Trace Heating' Element

5M Condensate Drain Pipe 'Trace Heating' Element

Any of the above MUST be fitted ONLY by a qualified competent person. Further details can be found in the relevant sales literature and at [www.baxi.co.uk](http://www.baxi.co.uk)

## 5 Operation

### 5.1 Operation Checking Procedure & Basic Fault Identification

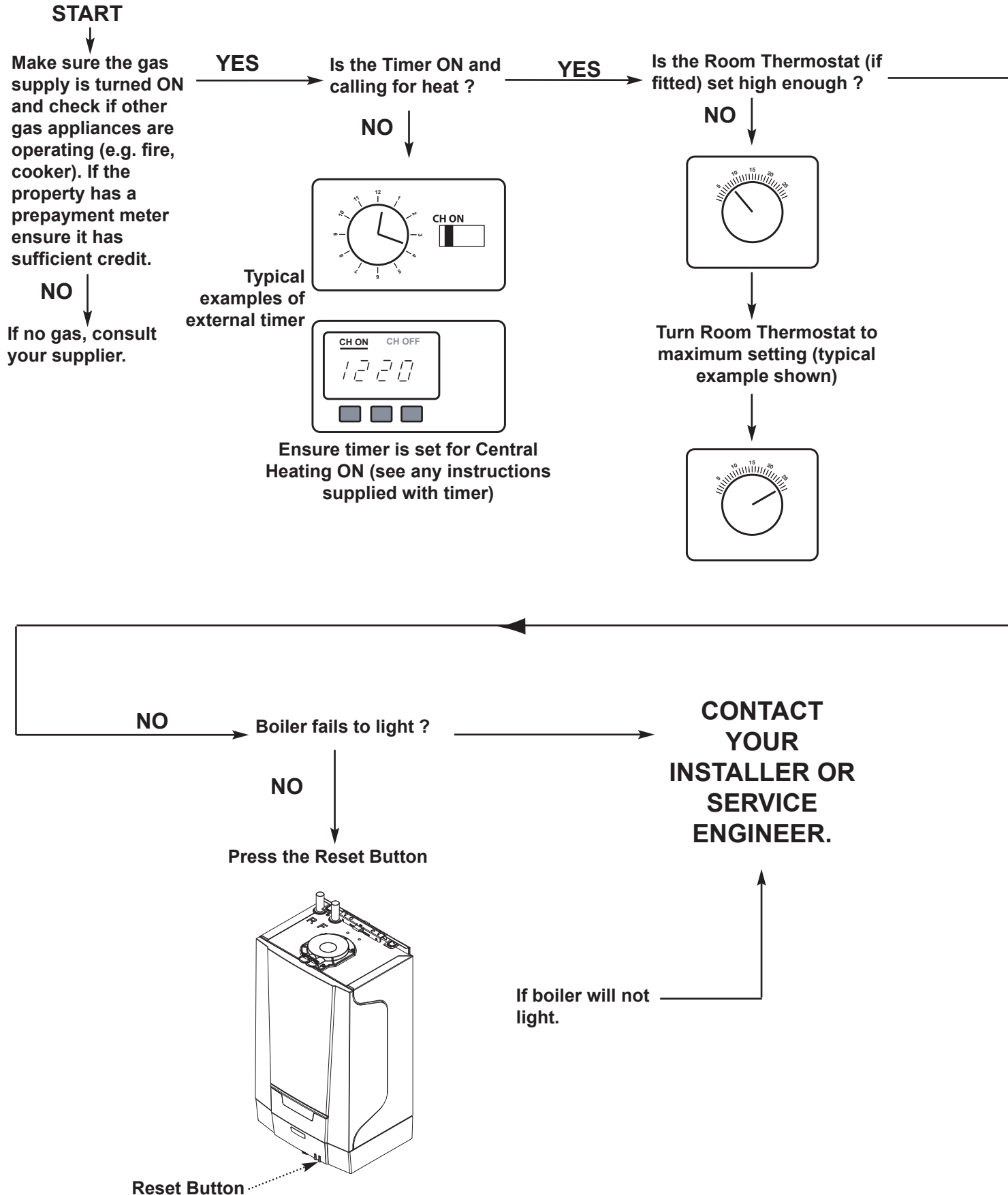



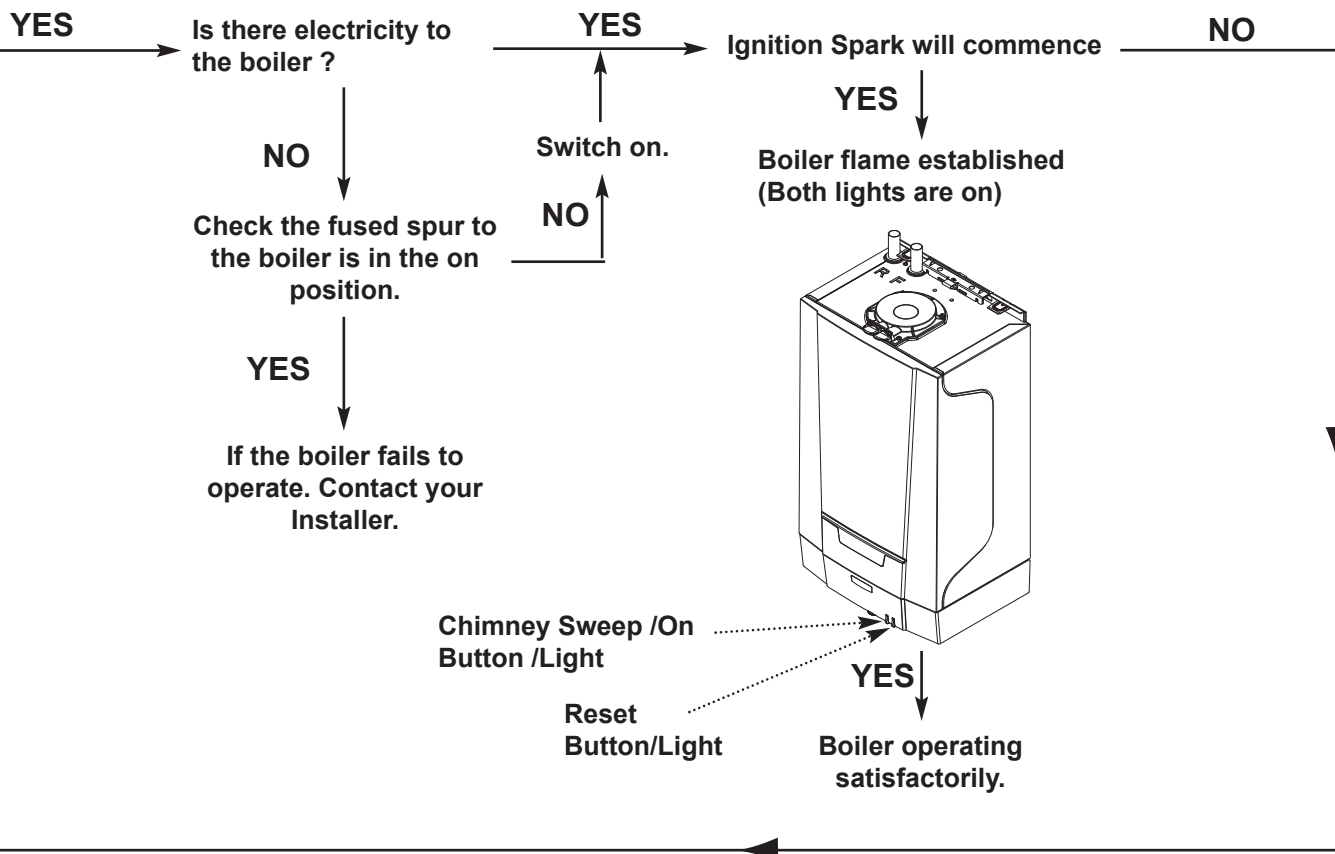

**If you don't know what you need to do to get the boiler to light, or need help with the system and controls, contact your installer as soon as possible**

## 5.2 Shutdown

---

1. If it is anticipated that the boiler will not be used for a long period or the property is to be unoccupied it is recommended that the system is drained if the electricity & gas supplies are to be turned off. Your installer will be able to offer advice.

## 5.3 Frost Protection

---

1. To prevent radiators and the system from freezing in rooms where there is a risk of frost (e.g. a garage or storage room), a frost thermostat can be connected to the system

# 6 Settings

---

## 6.1 Setting the Boiler Flow Temperature

---

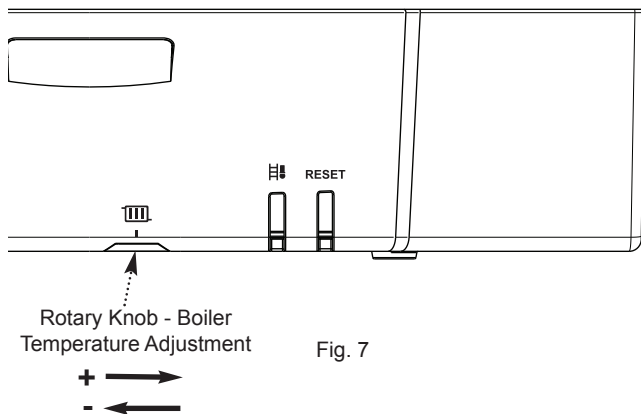

To increase or decrease the boiler temperature:-

1. Turn the rotary knob to the right (Fig. 7) to increase the boiler temperature.
2. Turn the rotary knob to the left (Fig. 7) to decrease the boiler temperature.
3. To achieve the required domestic hot water temperature the rotary knob must be set to a higher temperature than that selected on the cylinder thermostat.

## 7 Maintenance

---

### 7.1 General

---

1. The boiler does not require any special maintenance. However, the boiler must be serviced annually in accordance with the Installation and Service Manual and the relevant section of the Benchmark Service Record completed in order to maintain the warranty.



Taking out a maintenance contract is recommended.



#### CAUTION

Maintenance operations must be performed by a qualified competent person.

Use only genuine spare parts.

2. The painted panels should be wiped with a damp cloth and then dried completely. **DO NOT USE ABRASIVE CLEANING AGENTS.**

### 7.2 Maintenance Instructions

---

1. The central heating system should be checked regularly. Proceed as follows:

For Sealed Systems



If the water pressure is lower than 0.7 bar, the water must be topped up. If necessary: top up the CH system (recommended water pressure between 1 and 2 bar).

- Check radiators for leaks and (especially in damp areas) for rust.
- Open and close the radiator valves several times a year to ensure they can still be rotated.
- Only clean the outside of the boiler with a damp cloth. Do not use abrasive cleaning agents.



#### CAUTION

Only a qualified installer may clean the inside of the boiler.

## 7.3 Filling the System

---

The boiler will be installed on either an open-vented or sealed (pressurised) heating system. If you are unsure which type of system you have consult your installer.

Sealed systems may require periodic re-pressurisation. If this is required on a regular basis a fault or leak is indicated. Seek advice from your installer.

## 7.4 Venting the System

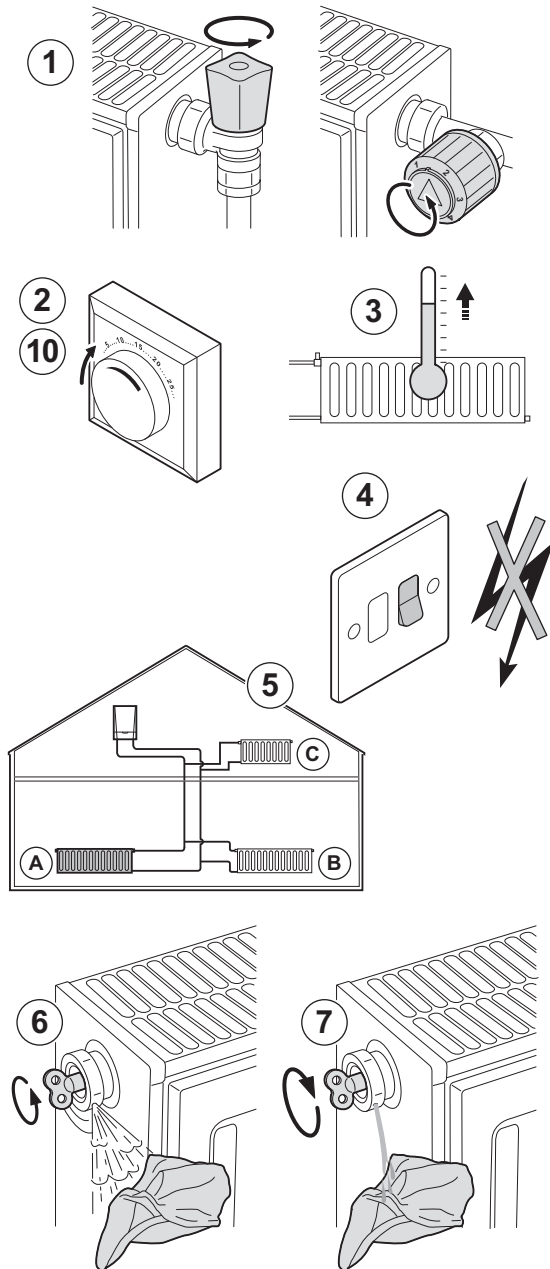

If any air is present in the appliance or system it must be removed in order to prevent nuisance noises that may occur during operation. The boiler has an inbuilt auto air vent to aid the removal of air and is supplied in the open position. Proceed as follows:

1. Open the valves of all the radiators connected to the system.
2. Set the room thermostat to the highest possible temperature and any timers to 'ON'.
3. Wait until the radiators are warm.
4. Switch off the boiler.
5. Vent the radiators. Work from the lowest radiator in the property.
6. Open the bleed vent with the key, keeping a cloth pressed against the vent.
7. Wait until water comes out of the bleed vent and then close.



### WARNING

The CH water in the radiators will still be hot.

8. Switch the boiler on.
9. After venting, if the system is of the sealed (pressurised) type check that the water pressure is still adequate.



For sealed systems - if the water pressure is lower than 0.7 bar, the water must be topped up (recommended water pressure between 1.0 and 2.0 bar when the system is cold).

10. Reset the room thermostat to the desired temperature..

## 7.5 Draining the System

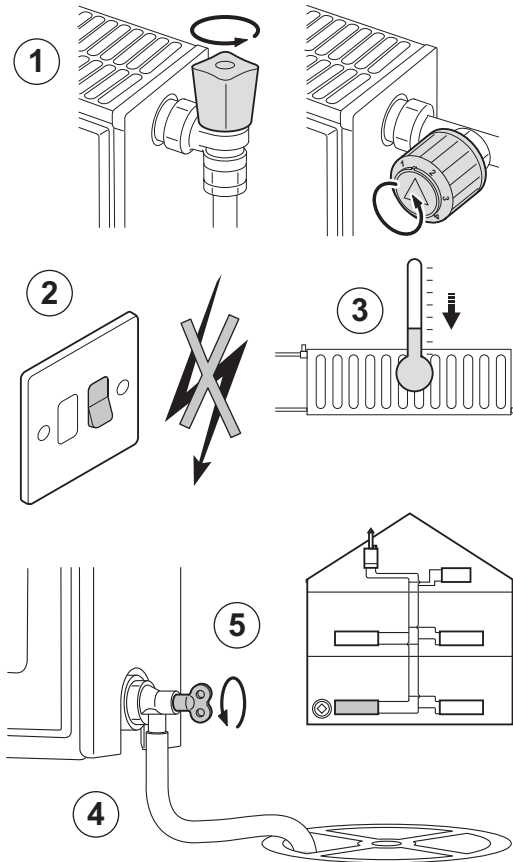

It may be necessary to drain the CH system if radiators need to be replaced or removed, if there is a major water leak or if there is a risk of freezing. Proceed as follows:

1. Open the valves of all the radiators connected to the system.
2. Switch off or disconnect the boiler's electrical isolation point.
3. Wait until all the radiators are cold.
4. Connect a drain hose to the lowest draining point. Place the end of the hose in a drain or at a place where drained water will not cause any damage.
5. Open the CH system drain valve. Drain the system.



### WARNING

The CH water may still be hot.

6. When water stops flowing from the draining point, close the draining valve.



See Section 7.4 Venting the system. If in doubt seek advice from your installer.

- After draining the concentration of system corrosion inhibitor and anti-freeze may become excessively diluted - seek advice from your installer.

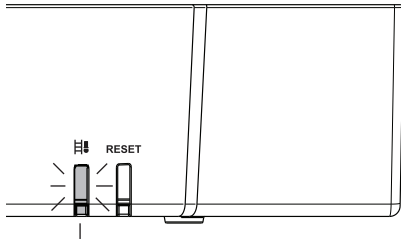

# 8 Troubleshooting

## 8.1 Fault Warning & Lock-out Codes



No. of Flashes	Green Light Flashing	Red Light Flashing
1	Temperature Protection	Sensor Error
2	Shutdown Input	High Temperature Protection
3	Flame Loss	Ignition Fault
4	Communication Fault	Fan Fault
5	Parameter Fault	Parameter Fault
6	Miscellaneous	Miscellaneous

1. The colour of the status light  on the boiler control panel and the number of times that it flashes indicates whether the boiler is working normally, has a problem or requires servicing.

**Fault - Warning** When flashing green  light indicates that the boiler has detected a problem, and is attempting to resolve it. If it does not succeed the boiler will go into lock-out mode and  will display a red light.

**Fault - Lock-out** When flashing red  light indicates that the boiler has a fault and has locked out. Press the RESET button for a minimum of 5 seconds to try and clear the fault condition.

2. A lock-out condition can be re-set up to 5 times within one hour using the reset button. Any fault that repeats regularly should be fully investigated and appropriate remedial actions taken by your Installer, Annual Service Provider or **Baxi Customer Support** - The Service Division of Baxi.

3. If there is a continuous red light, contact your Installer, Annual Service Provider or **Baxi Customer Support** - The Service Division of Baxi, and inform them of the fault code displayed.

4. You can contact **Baxi Customer Support** on **0344 871 1545**. When contacting **Baxi Customer Support** it will be useful to have the **'Benchmark Checklist'** at the back of the Installation & Service Manual to hand as it includes details relevant to the boiler and installation.

The  symbol indicates the flashing Status Light.

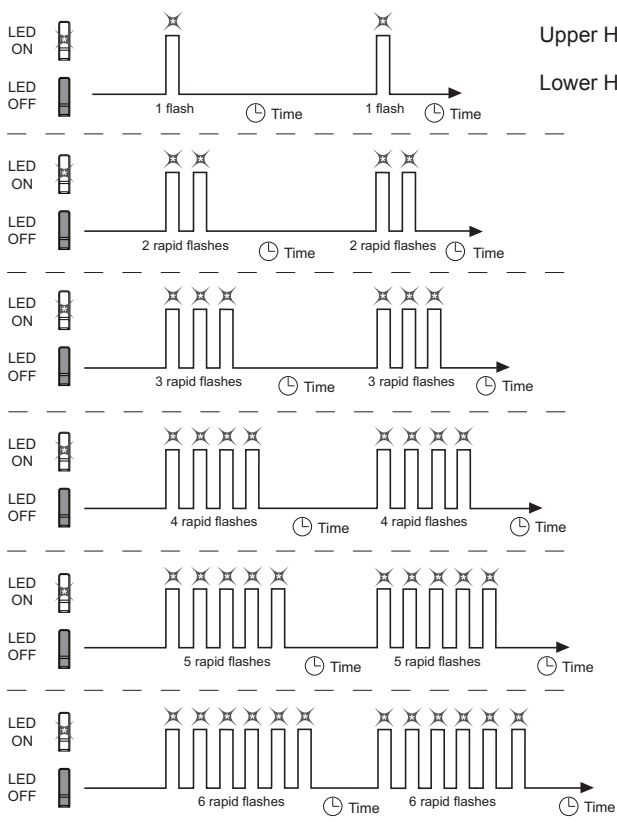

Upper Horizontal Line = Light ON  
Lower Horizontal Line = Light OFF

### Normal Operation

The  symbol indicates the Status Light ON.



Upper Horizontal Line = Light ON  
Lower Horizontal Line = Light OFF

## 8.2 Fault Finding

---

1. If the boiler is not working, check section 5.1 Operation Checking Procedure & Basic Fault Identification or the fault finding table. Contact your Installer.

Problem	Possible Causes
There is no domestic hot water and/or the radiators are cold.	Check that the boiler is being supplied with power (all controls set to ON). Check the fuses and the switches. If possible check whether the gas cock is properly open. If the property has a prepayment meter ensure it has sufficient credit.
The boiler is not working.	Check if the Fault - Lock-out is illuminated. See Section 8.1 to reset.
The domestic hot water is not hot enough.	The boiler temperature setting is below the cylinder thermostat setting.
The radiators are not hot enough.	The radiator valves are not open. The temperature set point for the heating is too low (check boiler & room thermostat).



## 9 Decommissioning

---

### 9.1 Decommissioning Procedure

---

**CAUTION**

Only qualified professionals are authorised to work on the appliance and system to decommission.

1. If your the boiler needs to be decommissioned either temporarily or permanently the following should be performed:

- Switch off the boiler.
- Switch off the boiler's electrical connection.
- Close the boiler gas valve.
- Drain the CH system.

Seek the advice of your installer.

## 10 Disposal

---

### 10.1 Disposal / Recycling

---

**WARNING**

Removal and disposal of the boiler must be carried out by a qualified installer in accordance with local and national regulations.

## 11 Environmental

---

### 11.1 Energy Saving

---

Tips on saving energy:

- ▶ Do not cover radiators. Do not hang curtains in front of radiators.
- ▶ Install reflective panels behind the radiators to prevent heat losses.
- ▶ Insulate the pipes in rooms that are not heated (cellars and lofts).
- ▶ Install loft insulation & double glazing.
- ▶ Use draught excluders where necessary.
- ▶ Upgrade any older external controls.
- ▶ Turn down room thermostats by 1°C
- ▶ Turn off radiators in rooms not in use.
- ▶ Do not run hot (or cold) water pointlessly.
- ▶ Fit a water-saving shower head to save up to 40 % energy.
- ▶ Take showers rather than baths. A bath consumes twice as much water and energy.

### 11.2 Room Thermostats and Settings

---

Various models of room thermostats are available. The thermostat type and setting affect the total energy consumption.

A few tips:

- ▶ Fully opening or closing thermostatic radiator valves result in unwanted temperature fluctuations. Turn the thermostat knob or valve higher or lower in small steps.
- ▶ Lower the thermostat to approximately 20°C. This reduces heating costs and energy consumption.
- ▶ When rooms are to be aired, lower the thermostat well in advance.
- ▶ When setting thermostats or programmers take account of days when nobody will be in and of holidays.

## 12 Warranty

---

### 12.1 General

---

To make sure your boiler warranty is activated and maintained, it is essential that the:

1. Benchmark checklist is completed by your installer
2. Warranty is registered within 30 days
3. Boiler has an annual service

Please note that failure to adhere to terms and conditions will make your warranty invalid.

### 12.2 Terms of Warranty

---

#### 12.2.1 Standard Warranty Terms and Conditions

---

##### Warranty Registration, Service & Repair

For full terms and conditions, visit [www.baxi.co.uk/terms](http://www.baxi.co.uk/terms).

##### Benchmark Checklist

The Benchmark Checklist will be completed by your installer and records that the boiler has been installed and commissioned correctly. It can be found at the back of the installation and service manual and should be kept in a safe place for the life of the boiler. We will check that the Benchmark Checklist has been completed on an in-warranty visit.

##### Ways to register your warranty

If your boiler is eligible for an extended warranty, your installer may register the product on your behalf and provide you with the relevant documentation. Please check with your installer.

Should this not be the case, you can register your warranty online at [www.baxi.co.uk/registration](http://www.baxi.co.uk/registration)

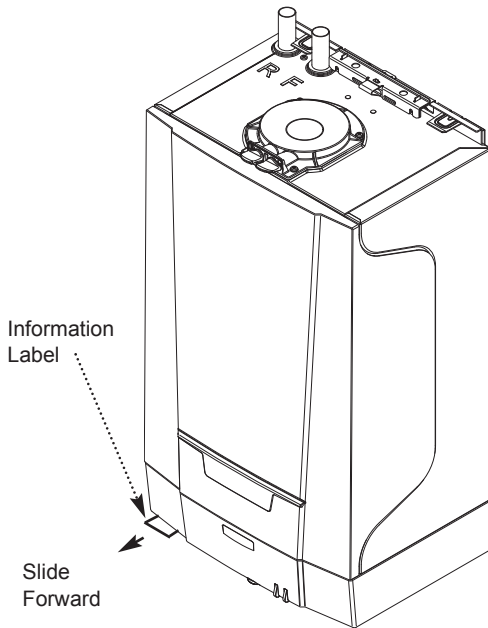

### Annual Service

A service must be completed every 12 months from the date of installation to maintain your warranty.

This service must be completed by one of the following:

- A Gas Safe registered installer/engineer
- Baxi Customer Support; call us 0344 871 1545

Please make sure that your engineer has logged the service information at the back of the installation and service manual. You will be asked for your service history on any in-warranty repair visit.

### If you experience a problem with your boiler

For any in or out of warranty repair, Baxi Customer Support is on hand to help you. Call our award-winning team to arrange for one of our nationwide team of Gas Safe registered engineers to visit.

If your product is in warranty, everything is free of charge, subject to our warranty terms and conditions. If it is out of warranty, we can still help and offer a range of options you can choose from to suit your needs.

### Contact Baxi Customer Support 0344 871 1545

#### Opening hours

Monday - Friday, 8.00am - 6.00pm

Weekends and Bank Holidays, 8.30am - 2.00pm

Please note calls may be recorded for training and monitoring purposes.

When contacting Baxi Customer Support, please have the following information to hand:

- Boiler serial number. This can be found on the appliance.
- Proof of purchase if you do not have the boiler serial number.

Please note that for in-warranty repairs, our engineers will ask to see your service history record, completed Benchmark Checklist and details of your installer. These can all be found in the installation and user manual.

## 13 Appendix

### 13.1 ErP Information

#### 13.1.1. Product Fiche - Boiler Space Heaters

Product fiche for boiler space heaters

<b>Baxi 800 Heat</b>		<b>816</b>	<b>825</b>	<b>830</b>
Seasonal space heating energy efficiency class		<b>A</b>	<b>A</b>	<b>A</b>
Rated heat output ( <i>Prated or Psup</i> )	kW	16	25	30
Seasonal space heating energy efficiency	%	93	93	93
Annual energy consumption	kWh	13889	21389	25834
	GJ	50	77	93
Sound power level $L_{WA}$ indoors	dB	39	45	49



#### See

For specific precautions about assembling, installing and maintaining, consult the relevant section as detailed on the Contents page.

13.1.2. Package Fiche - Boilers

Package fiche for boilers indicating the space heating energy efficiency of the package

Seasonal space heating energy efficiency of boiler

①  
I' %

Temperature control

from fiche of temperature control

Class I = 1%, Class II = 2%, Class III = 1.5%,  
 Class IV = 2%, Class V = 3%, Class VI = 4%,  
 Class VII = 3.5%, Class VIII = 5%

②  
 +  %

Supplementary boiler

from fiche of boiler

Seasonal space heating energy efficiency (in %)

③  
 $(\text{ } - \text{'I'}) \times 0.1 = \pm \text{ } \%$

Solar contribution

from fiche of solar device

Collector size (in m<sup>2</sup>)

Tank volume (in m<sup>3</sup>)

Collector efficiency (in %)

Tank rating <sup>(1)</sup>  
 A\* = 0.95, A = 0.91,  
 B = 0.86, C = 0.83,  
 D - G = 0.81

④  
 $(\text{'III'} \times \text{ } + \text{'IV'} \times \text{ }) \times 0.9 \times (\text{ } / 100) \times \text{ } = + \text{ } \%$

(1) If tank rating is above A, use 0.95

Supplementary heat pump

from fiche of heat pump

Seasonal space heating energy efficiency (in %)

⑤  
 $(\text{ } - \text{'I'}) \times \text{'II'} = + \text{ } \%$

Solar contribution AND Supplementary heat pump

select smaller value

⑥  
 $0.5 \times \text{ } \text{ OR } 0.5 \times \text{ } = - \text{ } \%$

Seasonal space heating energy efficiency of package

⑦  
 %

Seasonal space heating energy efficiency class of package

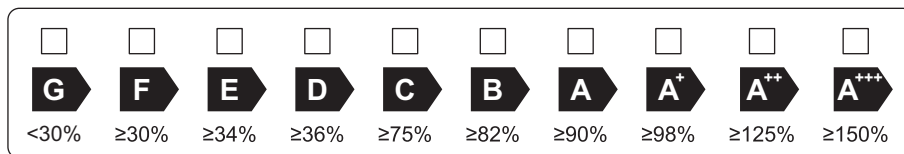

Boiler and supplementary heat pump installed with low temperature heat emitters at 35°C ?

from fiche of heat pump

⑦  
 $\text{ } + (50 \times \text{'II'}) = \text{ } \%$

The energy efficiency of the package of products provided for in this fiche may not correspond to its actual energy efficiency once installed in a building, as this efficiency is influenced by further factors such as heat loss in the distribution system and the dimensioning of the products in relation to building size and characteristics.

AD-3000743-01

- I The value of the seasonal space heating energy efficiency of the preferential space heater, expressed in %.
- II The factor for weighting the heat output of preferential and supplementary heaters of a package as set out in the following table.

### 13.1.2. Package Fiche - Boilers (cont)

- III The value of the mathematical expression:  $294/(11 \cdot \text{Prated})$ , whereby 'Prated' is related to the preferential space heater.
- IV The value of the mathematical expression  $115/(11 \cdot \text{Prated})$ , whereby 'Prated' is related to the preferential space heater.

#### Weighting of boilers

$\text{Psup} / (\text{Prated} + \text{Psup})^{(1)(2)}$	II, package without hot water storage tank	II, package with hot water storage tank
0	0	0
0.1	0.3	0.37
0.2	0.55	0.70
0.3	0.75	0.85
0.4	0.85	0.94
0.5	0.95	0.98
0.6	0.98	1.00
$\geq 0.7$	1.00	1.00

(1) The intermediate values are calculated by linear interpolation between the two adjacent values.  
(2) Prated is related to the preferential space heater or combination heater.

#### Package efficiency

<b>Baxi 800 Heat</b>		<b>816</b>	<b>825</b>	<b>830</b>
Temperature control X	%			
Temperature control Y	%			

## Baxi Customer Support



**0344 871 1545**

### Opening hours

Monday - Friday, 8.00am-6.00pm

Weekends and Bank Holidays, 8.30am-2.00pm

Please note calls may be recorded for training and monitoring purposes



**baxi.co.uk**

Register now to activate your warranty:

**[www.baxi.co.uk/registration](http://www.baxi.co.uk/registration)**

For the warranty to be maintained, please make sure...

- 1** Benchmark checklist is completed
- 2** Warranty is registered within 30 days
- 3** The boiler has an annual service

For full terms and conditions, visit [www.baxi.co.uk/terms](http://www.baxi.co.uk/terms). Failure to adhere to terms and conditions will void your manufacturer's warranty.



Baxi  
Brooks House,  
Coventry Road,  
Warwick, CV34 4LL



Please ensure the boiler is installed in accordance with these installation instructions and that you adhere to the Building Regulations.

e&oe

All descriptions and illustrations provided in this document have been carefully prepared but we reserve the right to make changes and improvements in our products which may affect the accuracy of the information contained in this leaflet. All goods are sold subject to our standard Conditions of Sale which are available on request.



**BAXI**